

SHRINK-FIT HOLDER **SLIMLINE**

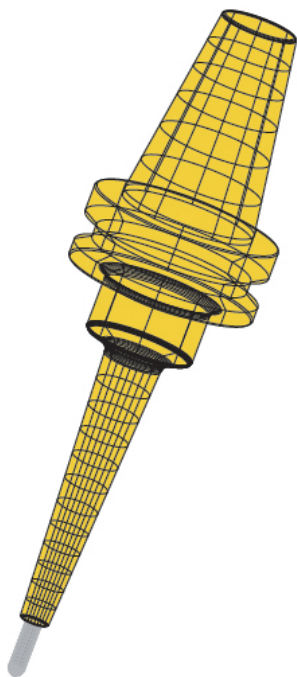

MST corporation

Vol. 4 
2305

Master Index

SLIMLINE Product Overview

4

Shrink-fit Heater

- Hot air heating type
- Induction heating type



Specifications · Dimensions

11

MONO Series

- Slim, high accuracy and rigidity solid type

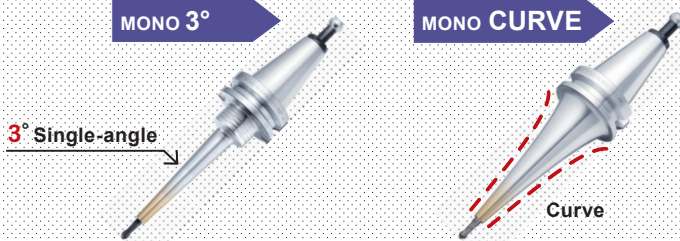

Overview · Model

18

BT30	20
BT40	23
BT50	47
A40	70
A50	74
A63	78
A100	111
E25	140
E32	142
E40	146
E50	153
F63	163
15T	180
S20T	181
RS20	182
CT50	183

Overview · Model

189

2 PIECE type

- Master holder and collet exchange modular type

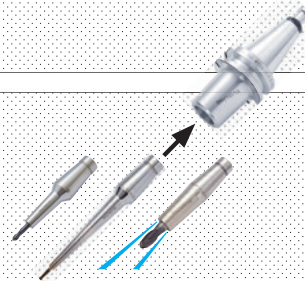

Product List	6 type	190
	8 type	191
	12 type	192

BLACK UNO

- Ultraprecise run-out accuracy

0.5 μm



UNO

1 μm



Overview · Model

197

Product List

198

HYPER version

- Gripping force and rigidity strengthening type



Overview · Model

199

Product List	Short type	200
	Heavy-duty type	201
	SLIMLINE Z	202

STRAIGHT arbor

- Straight shank type



Overview · Model

209

Product List

210

DETA-1 Collet Holder	214
COLLET HOLDER	215
Retention knob	216
Coolant duct	218

Related Products

- Collet holder, Retention knob



6S DESK	220
CLEAN BOX	221
TOOL CAP TCC type	222
ENDMILL HOUSE	223
TOOL HOLDER STORING CABINET	224
TOOL SET UP STAND	225
CLEANING TOOL STAR DUST	226
TEST BAR CHECKMATE	227
Goo CHECKER	228
MAINTENANCE VIDEO	229

Peripheral Equipment

- Washing machine, Work-table, Measuring equipment, Tool protection cover



Technical support	230
Instructions for use	231
Rigidity of SLIMLINE	234
For high-speed spindle rotation	237
Reference data	238
Technical data	241
OVERSEAS NETWORK	244

Technical Information



RELIABLE TOOLING

MST's tooling is subject to its own MST's 4 precision standards: taper contact, roundness, surface roughness and heat treatment. These are more precise than JIS or MAS standards. We provide trustworth products under strict quality control.

• MST's 4 precision standards

1 Taper contact	%	90
2 Roundness	μm	0.8
3 Surface roughness (Rz)	μm	0.6
4 Heat treatment	Material	SCM415
	Carburized depth	mm 0.8 ~ 1.0
	Quenching hardness	HRC 55 ± 2

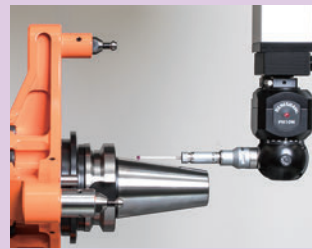
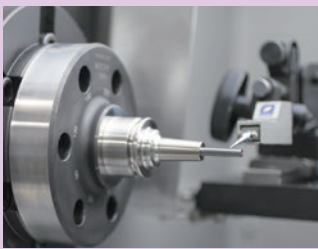

INDEX

	CODE	NAME	Page
A	ADH -HSK25	Adapter	15
	AP 40-T30 V	Adapter for pot	225
	AP 50-T30 H	Adapter for hanger	225
	AQC -AH-01	Aqua Cool	17
B	BAA -01	Base	15
	BAS -01	Adapter	15
	BL B3	3S Balloon	198
C	CBX -01	CLEAN BOX	221
	CD 40-01	Coolant duct	218
	CF 8-3-45	SLIMLINE collet>Flush type	189
	CLT -GTA3-5	Cleaning tool > Rubber grinding stone type	17
	CLT -NT30- G 2	CLEANING TOOL STAR DUST	226
	HSK40- CMA 20-125	TEST BAR CHECKMATE	227
	CN -103	Container box	17, 224
	CR 6-3-30	SLIMLINE collet>Regular type	189
	CS 6-3-15	SLIMLINE collet>Slim type	189
	CWB A01	Shrink-fit holder Chiller	17
E	EMO -SET-01	ENDMILL HOUSE	223
H	HAJ -3	Cutter adjuster	16
	HBX -A40	Tool holder storing cabinet	224
	HF -BT30	Tool set up stand>HF series	225
	HPY -01	Cutter Pliers	16
	HRB -01	HEAT ROBO Baby	14
	HRD -01S	HEAT ROBO DENJI	12
	HSA -EF	Cutter stopper>Coil spring type	16

	CODE	NAME	Page
H	HSB -6	Cutter stopper>Plate spring type	16
	HSC -3	Cutter stopper>Slit collet type	16
	HTB -01	Heat-resistant gloves	16
M	MY CUBE 50	MY CUBE	225
	MTN -BSK1	MAINTENANCE VIDEO	229
N	NOZ -M4	2 PIECE type > Coolant-through nozzle	193
P	P 30T-1	Retention knob	216
	P ETIT BALL 40	Petit Ball	225
S	SDH -01	Cutter Tray	16
	SDKT -RE	Holder Stand	16
	BT30- SLK 6-35	2 PIECE type > Master holder	189
	E25 - SL RA4-35 U/BU	UNO / BLACK UNO	197
	BT40- SL RA6-120 cv	MONO series>MONO CURVE	19
	BT40- SL RB20 S -70- M 41	HYPER VERSION >Short type	199
	BT50- SL RB20 H -110- M 42	HYPER VERSION >Heavy-duty type	199
	BT50- SL RA4-90- M 22	Mono Series > MONO 3°	18
	BT50- SL RA12 Z -105	HYPER VERSION > SLIMLINE Z	199
	SPY -01	Stopper Pliers	16
ST 10- SL SA3-80-M35	STRAIGHT arbor	209	
T	TW -4	Wrench	190
	TCC 0607-100	TOOL CAP TCC type	222
W	W -135	Wrench	193
Z	BT30- ZPM -165	Goo CHECKER	228
	0 6SD -01	6S DESK	220

SHRINK-FIT HOLDER
SLIMLINE

**SLIMLINE can be used with all high-speed,
high-precision machining centers.**

**SLIMLINE can be used in a wide variety
of applications.**

Fine-precision machining
High speed and high feed
High speed and heavy duty cutting
Simultaneous 5-axis machining
High quality machining
Linear motor drive

NAK81

Inconel Zirconia
62HRC Ti-6Al-4V
SKD61 STAVAX
Quartz glass

DMG MORI
HSC linear series

MAKINO

MAG, V22 / V33z, iQ300 / iQ500 / N2-5XA / V56i / D200Z

MAKINO J

J3 / L2

NIDEC

μV1 / μV5

MITSUI SEIKI

VL30 / VL50

ROKU-ROKU

P12-C genesis, Android II, MEGA / CEGA / HC series

SODICK

HP / UH / UX / OPM series, TT1-400A

SUGINO

Xion-III / Xion-II-5AX / V9 / NSU9 / H5 / H7 / H9 / SC Dual

YASDA

YMC series

Japan



MIKRON

HSM series / MILL S Precision series / XSM series

WILLEMIN-MACODEL

30 / 40 series, 508S / MT, 508 / 528TB

Switzerland

France

FOREST-LINE

Aerostar, Aeromill, Minumac, Vstar, etc.



CINCINNATI MACHINE
SMART-t, MAXOR

HAAS AUTOMATION

VF, UMC

U.S.A.

Italy

FIDIA

D Range, G996, HS664, BSEseries, D321

PARPAS

AERO, XS, LHS

Germany

CHIRON

Series08 / 12

EXERON

HSC-Line, HSC-MP-Line

HERMLE

C series

KERN

Micro, Evo, Pyramid Nano

OPS-INGERSOLL

V5 / 9, 550 / 650

ROEDERS

RXP, RXS, RHP, RXD

Medical

Optical communication

Aerospace

Car · Mobile

Fuel battery

Semiconductor device

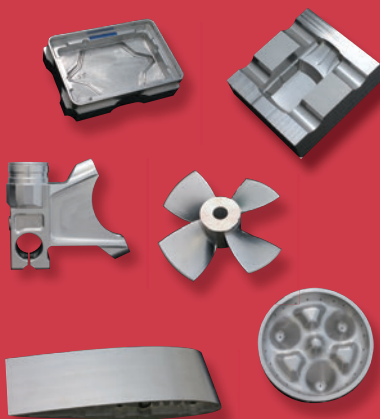

for High-accuracy, and High-efficiency machining **6** Points

1 The shortest
As short as possible

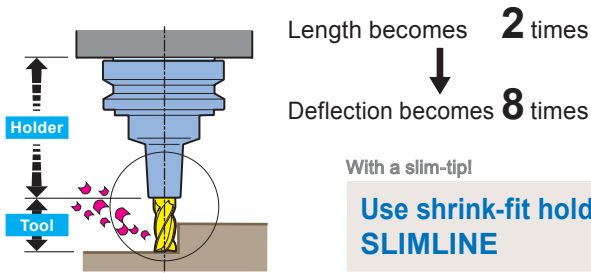

Deflection amount is proportional to projection length³.

2 Selection
Choose a tool holder that can clamp a cutting tool securely and with high accuracy.

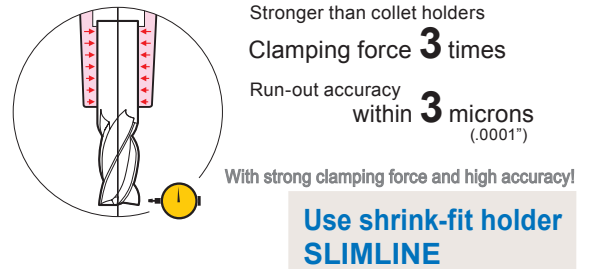

3 Quality
Do not use worn cutting tools.

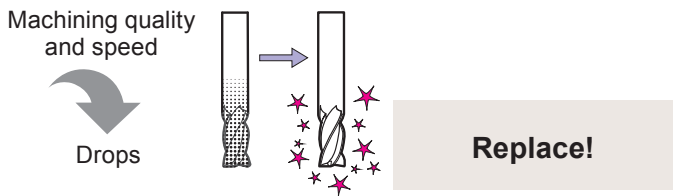

4 Cleanliness
Clean your tool holders and cutting tools.

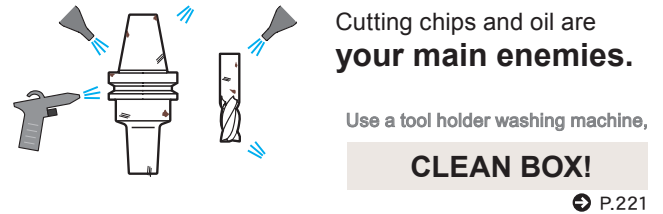

5 Cleanliness
Clean the machine spindle tapered hole.

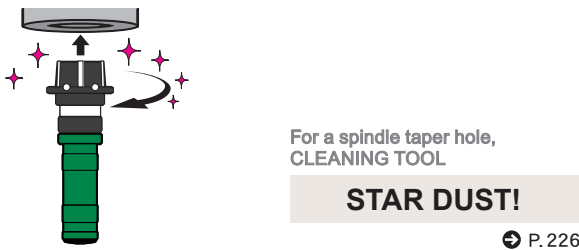

6 Accuracy
Machine spindle run-out accuracy should be within 10 microns (.0004").

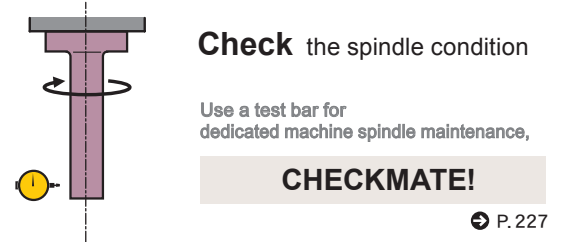

The **SLIMLINE** shrink-fit holder provides the perfect solution.

Do you have any of these problems?

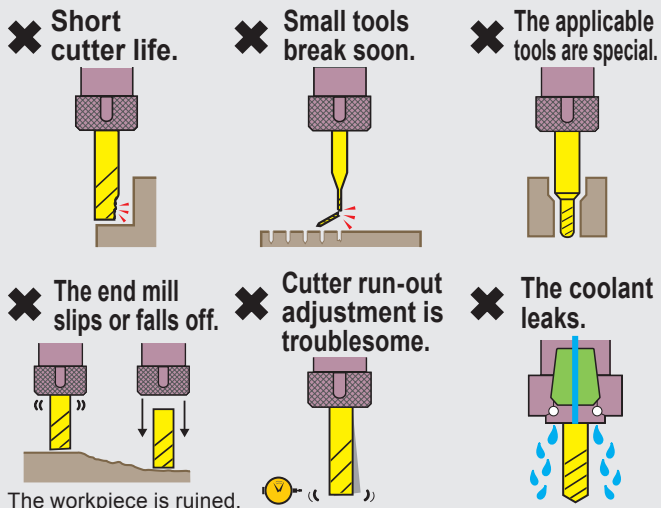

A simple chucking mechanism without any parts.

Stable gripping.
Gripping power 3 times.
No gaps.
No parts that could become loose.
Does not fall off even if vibrated.

Super-slim shape

Allows the holder to enter a workpiece. Can be used with a standard tool.

High accuracy

Twice the tool life.
Slim tools are also no problem.
Anyone can use them...



MST's SHRINK-FIT HOLDER SLIMLINE is

a system to hold tools (carbide) firmly and accurately by heating and cooling the holder (steel).

It is different from the existing mechanism of chucking, and is a revolutionary holder that uses the science of material expansion and shrinkage. SLIMLINE is made of MST's exclusive material which is developed to shrink-fit (insert/remove tool) easily at low temperatures (300°C [570°F] on average).

It also has a coefficient of thermal expansion that is 1.6 times higher than that of regular steel. Unlike conventional holders, SLIMLINE does not require any parts such as collets and nuts to hold tools. The simple mechanism can make the nose very thin, even to a thickness of

1.5mm[.06"], and achieve the slimmest holder on the market. It creates less work-piece interference and minimizes cutter projection in order to achieve stable and high-rigidity machining.

Our line-up contains 4,000 kinds to offer the most suitable holder design for a large variety of work-piece shapes. These are benefits that only SLIMLINE can offer.

We promise that SLIMLINE will demonstrate its outstanding capabilities in 5-axis, micro-precision, heavy-duty, and many kinds of machining in order to improve accuracy, extend tool life and reduce production cost.

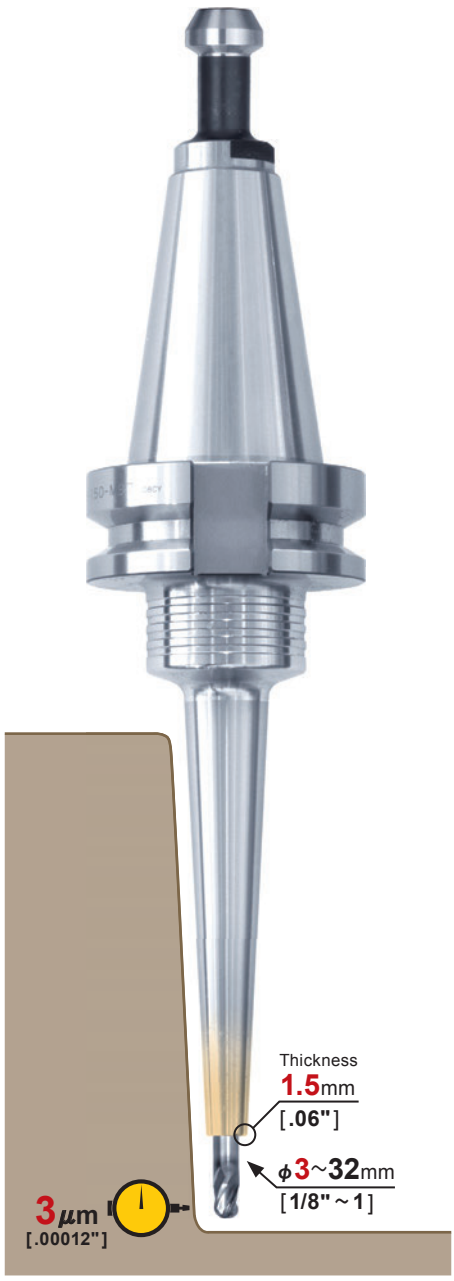

PAT.

Principle of shrinking technology

- A shrink-fit holder is a chucking system that utilizes the difference between the coefficients of thermal expansion of the holder material (steel) and the cutter (carbide).

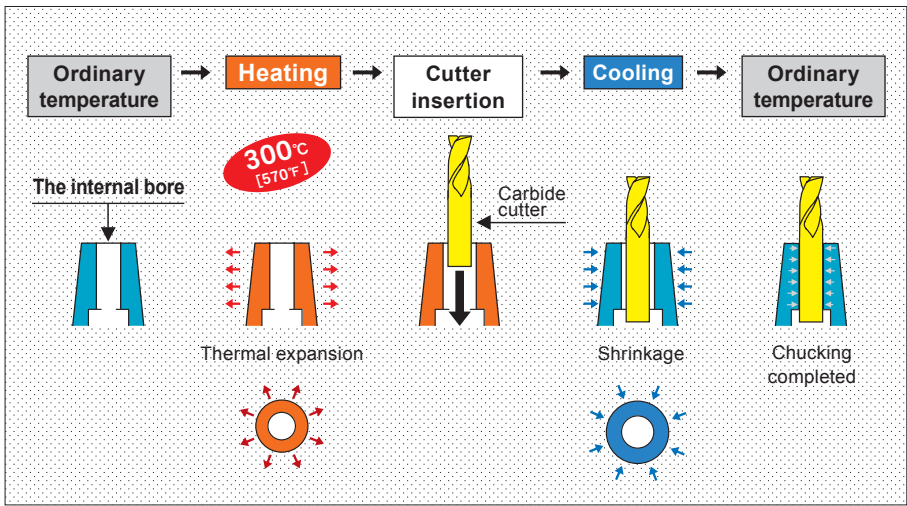

Special material for shrink-fitting

Thermal expansion coefficient is **1.6** times higher.

- Special material is applied to MST's shrink-fit holders. This material has a higher coefficient of thermal expansion than that of competitor's shrink-fit holders, and you can shrink-fit at lower temperatures than that of competitors. Also, due to its superior heat resistance temperature, the holder doesn't receive any damage by overheating.

Shrink-fitting temperature and heatproof temperature

MST's SLIMLINE

Heatproof temperature

- You can heat it up to 720°C [1310°F] without any issue.

Shrink-fitting temperature

- Since the heating temperature is lower than 430°C [810°F], there is no adverse impact on holder life.

Coefficient of thermal expansion

- Between the holder(special material) and cutter(carbide).
... 10.5×10^{-6} mm/°C

1.6 times
(Compared to competitors' holders)

Long service life

The tip of the shrink-fit holder doesn't get burned due to the low heating temperature.



Heatproof temperature
720°C
[1310°F]

Safety ratio

Maximum heating temperature
430°C
[810°F]

Shrink-fitting temperature

Short life

The shrink-fit holder burns due to the high heating temperature.

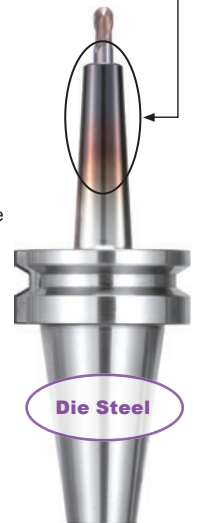

Maximum heating temperature
690°C
[1270°F]

Over Heating

Heatproof temperature
580°C
[1080°F]

- Oxidation
- Contraction of a bore dia.
- Reducing hardness

The difference between the maximum heating temperatures of MST's shrink-fit holders and our competitors' (3mm dia. shank cutter).

The lifetime of shrink-fit holder

MST's SLIMLINE

A shrink-fit temperature of a SLIMLINE holder is as low as 430°C [810°F] maximum. It never exceeds a heatproof temperature of 720°C [1310°F]. Repetitious shrinkage fitting does not cause the deterioration of a holder.

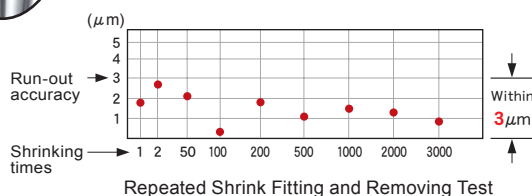
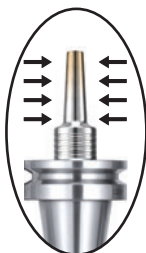

Competitors' shrink-fit holder

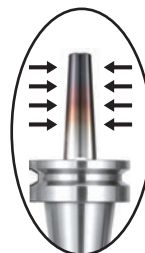

Heating several times at 700°C [1290°F]

The internal bore
Contraction of a bore dia.

The cutter is difficult to insert. Run-out accuracy deteriorations.

Repeated over-heating causes change in properties of the materials, the holder will be reduced performance.

High rigidity

Shortest cutter projection

- 1.5mm [.06"] thin wall thickness and slim body design minimize interference with a work-piece, fixture and cutting tool projection. This improves cutting tool life and machining surface quality dramatically thanks to minimal deflection and chattering.

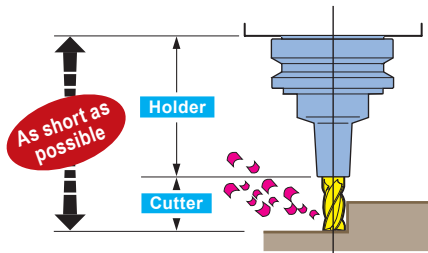

Deflection amount is proportional to **projection length³**.

Length becomes **2** times → Deflection amount becomes **8** times

$$S = \frac{6.8 \times F \times L^3}{E \times D^4}$$

S : Deflection amount D : Shaft diameter
L : Tool projection F : Load
E : Young's modulus

Displaying the highest performance at deep machining

- The holder tip thickness with 1.5mm [.06"] minimizes interference against the workpiece and jig fixtures.

MST's SLIMLINE

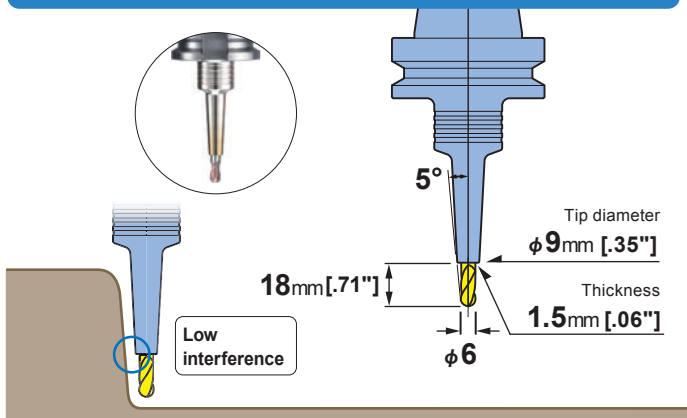

Competitors' shrink-fit holder

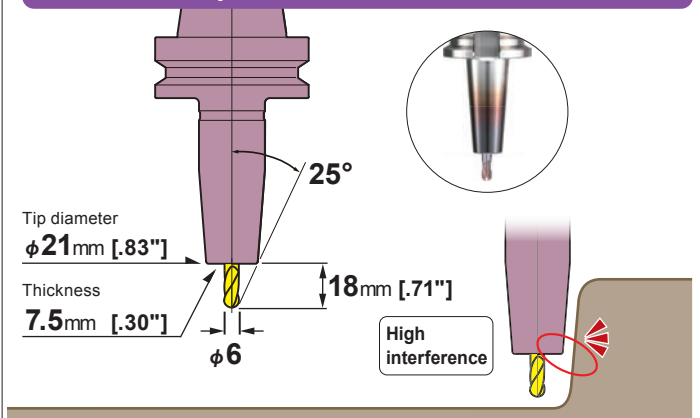

Surface roughness
Rz = **2 μm**
[.0001"]



SLIMLINE

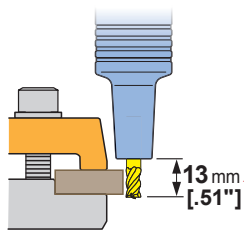

Rigidity
12 times

Surface roughness
Rz = **7.2 μm**
[.0003"]



Collet chuck

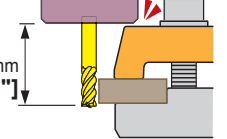

High clamping force

Ideal for heavy-duty machining.

Clamping force **3** times

High Clamping force

1100 N·m

320 N·m

350 N·m

330 N·m

φ20mm [.78"]

High run-out accuracy

Stable high run-out accuracy can be achieved at all times.

- There are no tightening parts (such as nuts and collets) to hold cutters. The simple design maintains high-accuracy chucking.

2 PIECE type

Master holder
SLIMLINE collet

12 type → **5 μm** [.0002"]
6 type → **3 μm** [.00012"]
8 type → **3 μm** [.00012"]

MONO 3° MONO CURVE

3 μm [.00012"]

UNO

1 μm [.00004"]

BLACK UNO

0.5 μm [.00002"]

No deterioration in accuracy after shrinking more than 3000 times

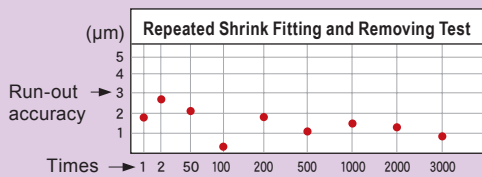

Easy operation



For COOLANT through

Withstanding pressure 15MPa

7MPa (NOZZLE through)

- The shrink-fit holder has a very simple configuration without a collet or a tightening nut. It is easily and completely compatible with through spindle coolant.

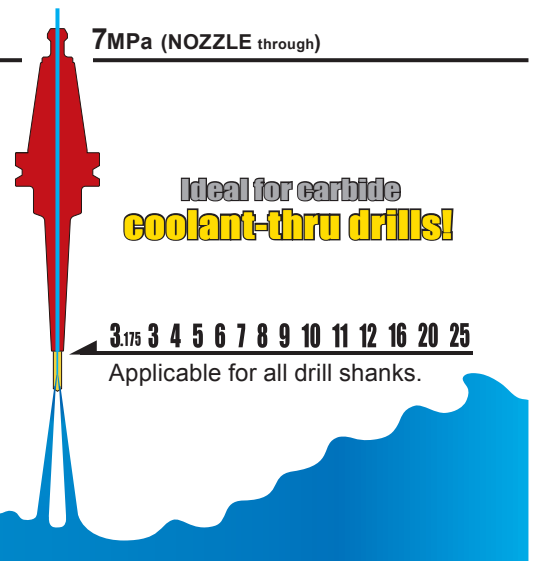
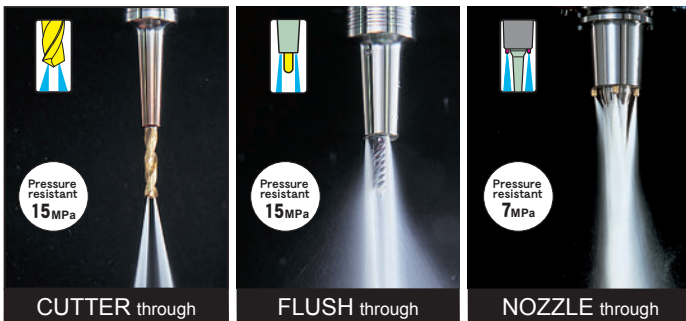

Rigidity calculation software

Holder automatic selection

- Automatically select optimum holders in the order of smaller deflection value S by inputting tool and work-piece information.

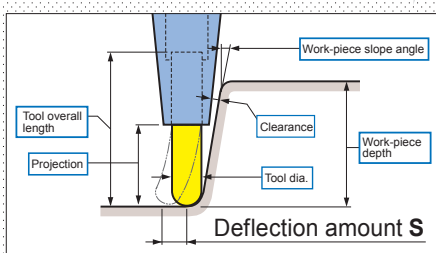

Enter your tool holder, cutting tool, and work-piece information.

➔ P.236

No.	Holder	Deflection amount
1	BT40-SLSA6-150cv	3.2
2	BT40-SLSA6-120cv	4.8
3	BT40-SLSA6-180cv	5.2
4	BT40-SLSA6-125-M42	5.6
...

This system lists tool holders in descending order of rigidity.

Output DXF files.

USER Customization

Modifying outer-dimension

- When you have interference using a standard holder, you can customize it yourself.

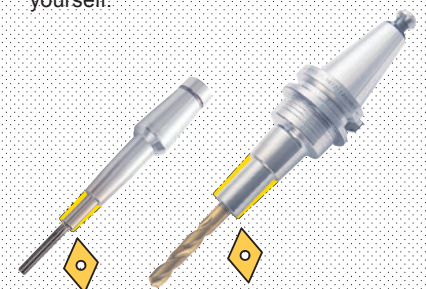

- ➔ P.233
- MST can customize upon your request.
 - There is a dimensional limitation for customizing.

A broad line-up

4000 types

MST's shrink-fit holder, SLIMLINE has an amazing line-up for all kinds of applications! For example, you can choose the optimum design holder for your needs from 300 types of the HSK-A63 shank.



MONO SERIES → P.18

Solid type

MONO 3°

Ideal for deep and straight wall milling applications.
3000 variations

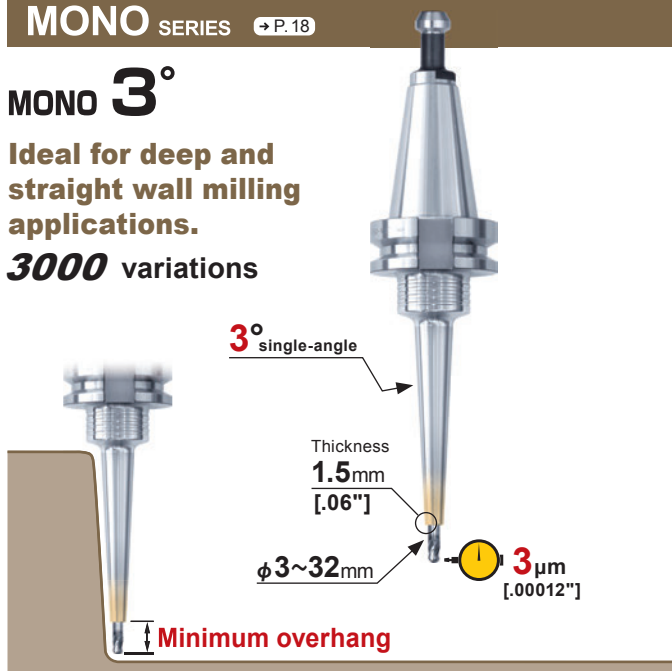

MONO CURVE

Ideal for 5-axis applications.
500 variations

PAT.

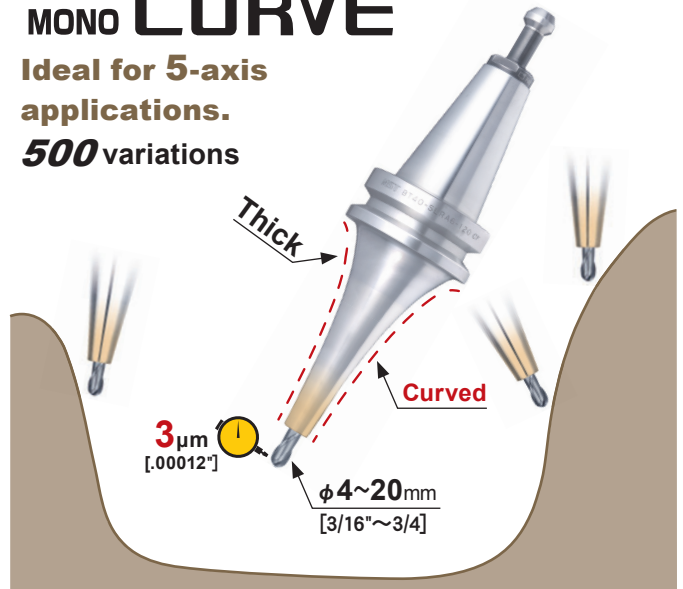

2 PIECE type → P.189

Modular type

Highly versatile
250 variations

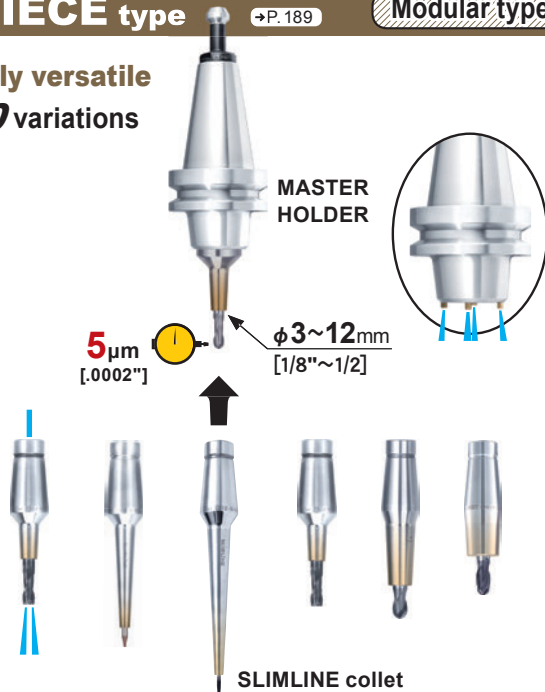

UNO → P.197

Solid type

Superior accuracy

PAT.

BLACK UNO

UNO

0.5μm [.00002"]

1μm [.00004"]



HYPER VERSION → P.199

Solid type

Heavy-duty endmill holder with high clamping force

PAT.

Short type

Heavy type

SLIMLINE Z

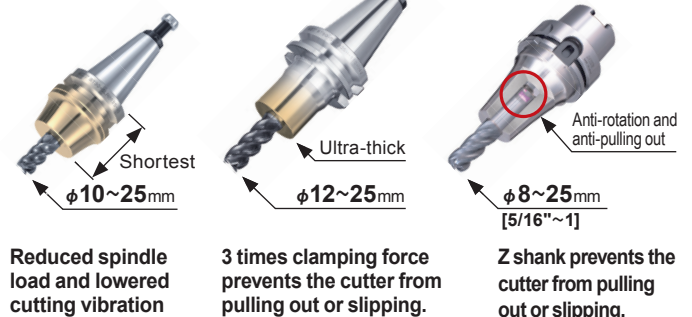

Reduced spindle load and lowered cutting vibration

3 times clamping force prevents the cutter from pulling out or slipping.

Z shank prevents the cutter from pulling out or slipping.

Feature

Shrink-fit Holder

MONO 3° MONO CURVE

MONO Series

2PIECE type

UNO

HYPER version

STRAIGHT holder

OTHERS

PERIPHERALS

Technical Information

Production improvement examples

Examples 1 Interference avoidance

- Replacing the long ball endmill with the standard ball endmill.
Rigidity of the holder was improved and allowed chattering-free machining.

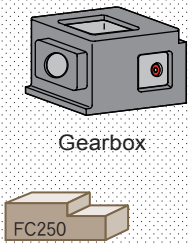

Tool cost
reduction
¥31,600 → ¥11,500

Improved
cutting feed
256 → 860 mm/min

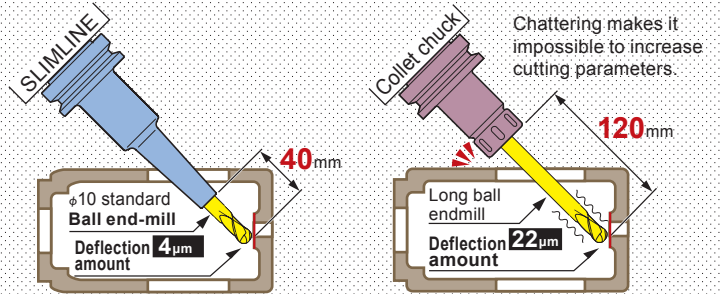

Examples 2 Improved run-out accuracy

- Improve run-out accuracy thanks to minimizing a drill projection. And, preventing expansion of drill hole diameter.



Tool life
2 times longer

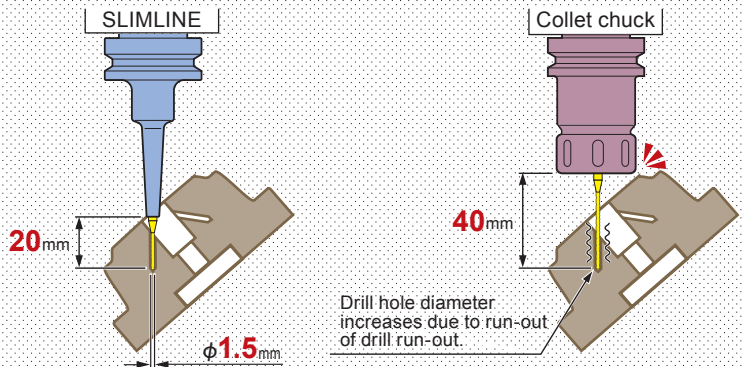

Examples 3 Heavy-duty machining of tough materials

- The anti-slippage and anti-pulling out capabilities of the SLIMLINE Z improve machining efficiency dramatically when performing side face heavy-duty machining.

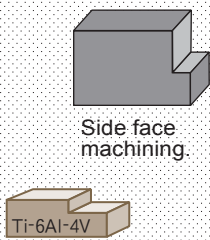

Cutting amount
2 times larger
256 → 504 cm^3/min

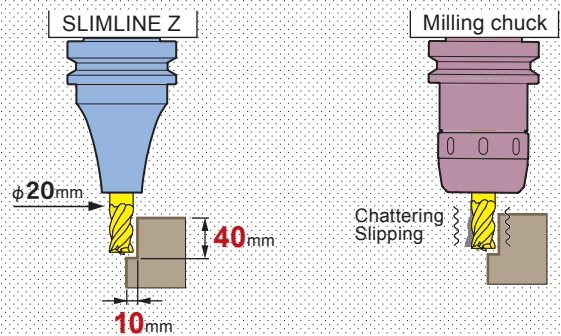

Examples 4 Mirror finishing

- The SLIMLINE BLACK UNO makes $1\mu\text{m}$ axial cutting micro-machining possible.

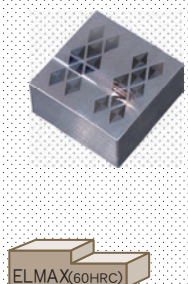

Surface roughness
improved **2 times**
Ra 120 → 60nm

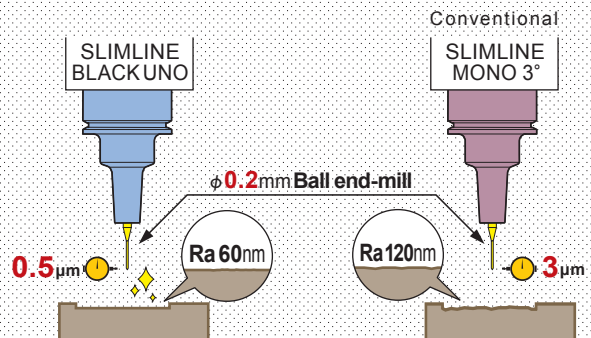

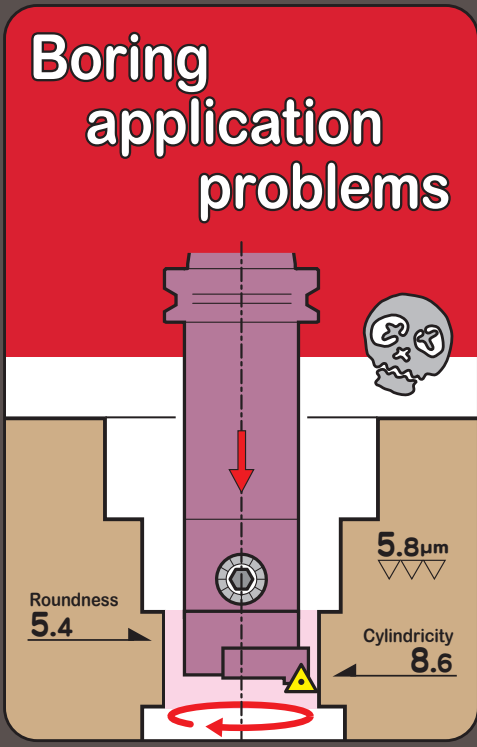

Solution

SLIMLINE
+
carbide arbor
+
Indexable
End Mill

Machining width
0.03mm

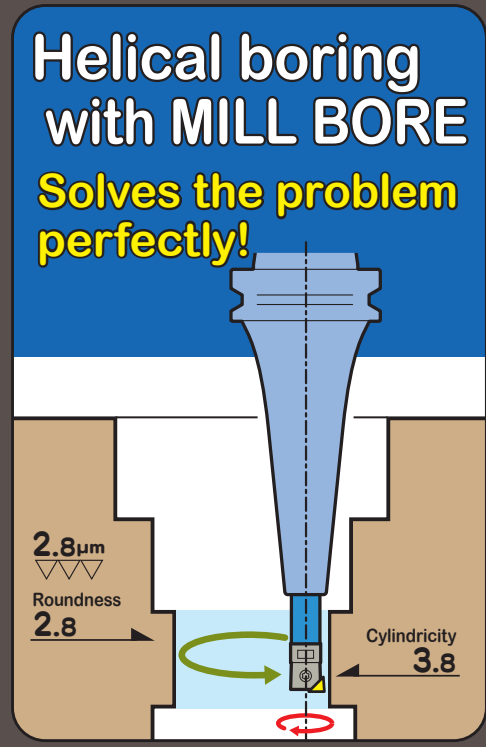

NEW PRODUCT

SHRINK-FIT HOLDER
SLIMLINE

MILL BORE

If you would like more detailed information, please contact MST and ask for a catalog.



Diameter adjustment is required on tool pre-setter

Cutter compensation with helical milling

Limited insert variations

Wide variety of cutter types, inserts (material/application)

Need to purchase separate holders for each diameter

1 holder can be used for various diameters

Long, connected cuttings Damages machining surface Leads to machine trouble

Milling creates only small chips Automation / Manpower saving

Shrink-fit Heater **HEAT ROBO**

Long holder life

Shrink-fitting temperature is comparatively low, about 300°C[570°F], which is safer for the holders.
Affordable and compact design for simple shrink fitting.

Induction Heater

HEAT ROBO 電磁 DENJI

- Rapid shrink-fitting
- Compact A4 size~
- Easy operation with touch panel!



Hot-air Heater

HEAT ROBO Baby

- Compact Affordable
- No risk of overheating



	DENJI 電磁 5000S	DENJI 電磁 2500	DENJI 電磁 1200S	Baby 3000S	Baby 1200S	Baby 1000
CODE	HRD-02SH	HRD-03	HRD-01S	HRB-03S	HRB-02S	HRB-01
Heating method	Induction type			Hot air type		
Rated power consumption	5000w	2500w	1200w	3000w	1200w	1000w
Rated voltage	3 phases 200~240v	Single phase 200~240v	100v	Single phase 200v	100v	
Cutter dia.	φ3~32 [1/8"~1]	φ3~16 [1/8"~5/8]	φ3~12 [1/8"~1/2]	φ3~32 [1/8"~1]	φ3~12 [1/8"~1/2]	
Heating time (dia.φ6)	18 sec. (Auto setting)	25 sec.	18 sec.	70 sec.	120 sec.	180 sec.
Cooling method*	○ (1min.)			○ (5min.)	▲	
Size (WxDxH) mm	340×470×750		230×540×550	430×330×660	370×260×590	320×160×410

※About cooling method [○]: Air cooling using factory air. [▲]: Cooling operation using air cooling capability of a hot air heater.

Compatibility table by holder type

Holder Type	5000S	2500	1200S	Baby 3000S	Baby 1200S	Baby 1000
MONO series	○	△	△	○	△	×
2 PIECE type	○	○	○	○	○	○
UNO	○	○	○	○	○	×
HYPER VERSION	○	×	×	○	×	×
STRAIGHT arbor	○	△	▲	▲	▲	×

[○]: Available [×]: Not available [△]: Refer to size chart [▲]: Requires recombinations of adapters and bases.

*Please verify compatibility for specific holders.

Feature

Shrink-fit Heater

MONO 3° MONO CURVE

MONO Series

2PIECE type

UNO

HYPER VERSION

STRAIGHT arbor

OTHERS

PERIPHERALS

Technical information

INDUCTION HEATER

DENJI 電磁 5000S

CODE	Size (W×D×H)	Rated voltage	Kg
HRD-02SH	340×470×750mm	3 phases 200-240v	30

Option

- Heating coil(HRD2-CL) •Coil stand
- Please choose parts on P.15-17

Std. Access.

- Heat-resistant gloves •Tweezers

Note

- Use type HSB/HSC for cutter stopper.
- Compressed air required: 0.5MPa (air-consumption volume: 245l/min)
- The customer should prepare the following items : auxiliary parts including the air tube (O.D. : 8mm.) an air filter and a coupler.

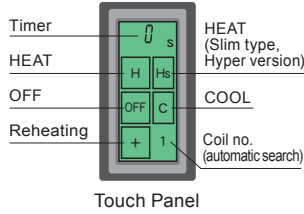

Max. Cutter dia.

φ3~32 [1/8~1"]

Rated power consumption

5000w

Cutter dia. φ6

Heating 18 sec.

Air-cooling

1 min.

Heating coil (Option)

CODE	Heating coil No.	Holder I.D.	Heating time (Auto setting)	φC	H	Protection sheet for heating coil
HRD2-CL1	1	φ3~ 6 [1/ 8" ~ 1/4]	18 sec.	25	33	HRD2-DN1
-CL2	2	φ7~12※1 [5/16" ~ 1/2]	28 sec.	35	42	-DN2
-CL3	3	φ16, 20※2※3 [5/ 8", 3/4"]	28 sec.	45	47	-DN3
-CL4	4	φ25 [1"] MONO series •MONO 3°[A50M-SLRB20, F63-SLFB20]	40 sec.	55	57	-DN4
-CL5	5	MONO series •MONO 3°[SLRB-SLFB8/10/12/16-M22]	35 sec.	Fig.1		-DN5
-CL6	6	HYPER VERSION •Short type(All sizes) •Heavy-duty type [φ 12, 25]	40 sec.	60	47	-DN6
-CL7	7	φ32, HYPER VERSION •Heavy-duty type [φ20, 25]	60 sec.	70	67	-DN7

Std. Access.

- Protection sheet for heating coil

Note

- The coil protection sheet is a consumable part. Replace the coil protection sheet(option) when you see that it is colored or distorted by the heat.

Caution

- To protect the heating coil, don't heat a holder without using a coil protection sheet.
- When ordering, please note that holders for coil 5, 6, or 7 cannot be heated by 2, 3, or 4.
 - ※1 Use the coil, No.5 for SLRB-SLFB8/10/12-M22.
 - ※2 Use the coil, No.5 for SLRB-SLFB16-M22.
 - ※3 Use the coil, No.4 for A50M-SLRB20, E50-SLRA16-60-M22, E50-SLRA20-65-M22, F63-SLFB20



Fig.1

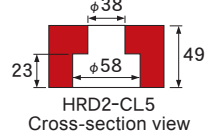

DENJI 電磁 2500

One Heating Coil supports dia.3-16mm of shrink-fit holder SLIMLINE. You can escape the inconvenience of changing heating coils.

CODE	AREA	Holder I.D.	Size (W×D×H)	Rated voltage	Kg
HRD-03-L	Japan, North America	φ3~16 [1/8" ~ 5/ 8]	340×470×750mm	Single-phase 200-240v	30
-S		φ3~ 8 [1/8" ~ 5/16]			
-LSE	Europe, Asia	φ3~16			
-SSE		φ3~ 8			

Option

- Please choose parts on P.15-17

Std. Access.

- Heat-resistant gloves •Tweezers
- Protection sheet for heating coil

Note

- Use type HSB/HSC for cutter stopper.
- Compressed air required: 0.5MPa (air-consumption volume: 245l/min)
- The customer should prepare the following items : auxiliary parts including the air tube (O.D. : 8mm.) an air filter and a coupler.

Caution

- The HEATROBO DENJI 2500 (HRD-03) is unable to shrink the HYPER version.

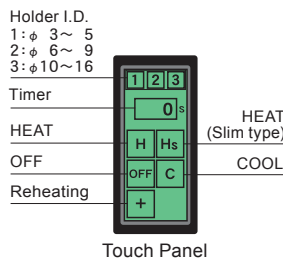

Max. Cutter dia.

φ3~16 [1/8~5/8"]

Rated power consumption

2500w

Cutter dia. φ6

Heating 25* sec.

Air-cooling

1 min.

*HRD-03-S/SSE is designed for dia.3 to 8mm, you can shrink-in and out in a short time.

Protection sheet for heating coil

CODE	Shrink-fit Heater
HRD3-DN1	HRD-03-L / LSE
-DN2	-S / SSE

Note

- The coil protection sheet is a consumable part. Replace the coil protection sheet(option) when you see that it is colored or distorted by the heat.

DENJI 電磁1200S

CODE	AREA	Size (W×D×H)	Rated voltage	
HRD-01S	Japan	230×410×550mm	100v	14
-01S-120NA	North America	230×540×550mm	120v	19
-230AS	Asia		Single phase 230v	

Option

- Please choose parts on P.15-17

Std. Access.

- Heating coil(HRD-CL) •Heat-resistant gloves
- Tweezers

Note

- Use type HSB/HSC for cutter stopper.
- Compressed air required: 0.5MPa (air-consumption volume: 245l/min)
- The customer should prepare the following items : auxiliary parts including the air tube (O.D. : 8mm.) an air filter and a coupler.
- A transformer is required in Europe. Please consult MST about the details of the transformer.

Caution

- The HEATROBO DENJI 1200S (HRD-01S) is unable to shrink certain holders. For details, refer to P.233.

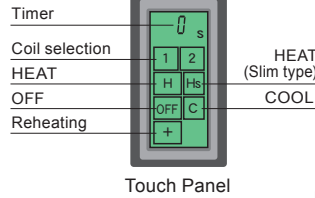

- Max. Cutter dia. $\phi 3\sim 12$ [1/8~1/2"]
- Rated power consumption **1200w**
- Cutter dia. $\phi 6$
- Heating **18 sec.**
- Air-cooling **1 min.**

Heating coil

CODE	Heating Coil No.	Holder I.D.	Heating time	ϕC	Protection sheet for heating coil
HRD-CL1	1	$\phi 3\sim 6$ [1/8" ~ 1/4"]	18 sec.	18	HRD-DN1
-CL2	2	$\phi 7\sim 12$ [5/16" ~ 1/2"]	33 sec.	28	-DN2

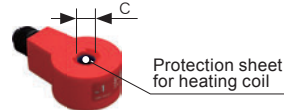

Std. Access.

- Protection sheet for heating coil

Caution

- To protect the heating coil, don't heat a holder without using a coil protection sheet.

Note

- The coil protection sheet is a consumable part. Replace the coil protection sheet(option) when you see that it is colored or distorted by the heat.

Coil stand

For the heating coil of HRD-02SH

CODE
CLSD01

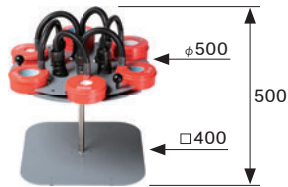

※Heating coils are not included.

Feature

Shrink-fit Heater

MONO 3°
MONO CURVE

MONO Series

2PIECE type

UNO

HYPER VERSION

STRAIGHT arbor

OTHERS

PERIPHERALS

Technical information

HOT AIR HEATER

Baby 3000S

CODE	Area	Size (W×D×H)	Rated voltage	kg
HRB-03S	Japan	430×330×660mm	Single phase 200 v	9.5
-03S-230NA	North America		Single phase 230 v	
-230EU	Europe			
-230AS	Asia			

Option

- φ70 Nozzle •Please choose parts on P.15-17.

Std. Access.

- Safety timer •Heat-resistant gloves •Tweezers

Note

- Compressed air required: 0.5MPa(air-consumption volume: 245 l/min)
- Prepare an air tube (O.D.: 8mm) and a connection coupling.

Shrink-fit heater with the safety timer.

Prevent accidents caused by leaving the heater on.

CODE	Area	Size (W×D×H)	Rated voltage	kg
HRB-03ST	Japan	430×330×660mm	Single phase 200 v	9.7
-03ST-230NA	North America		Single phase 230 v	
-230EU	Europe			
-230AS	Asia			

φ70 Nozzle

When heating the SLIMLINE MONO 3°, SLRB32, and the heavy-duty type Hyper Version, the 70mm dia. nozzle HRB-NZL70 is required.

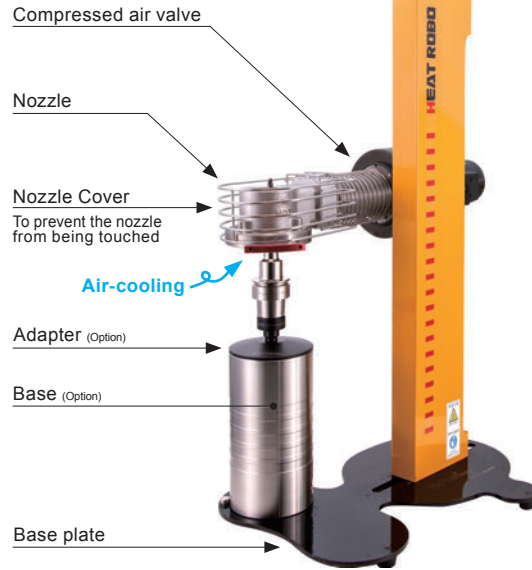

Max. Cutter dia.
φ3~32 [1/8~1"]

Rated power consumption
3000w

Cutter dia. φ6
Heating **70 sec.**

Air-cooling
5 min.

It's an eco-friendly heater, preventing overheating and conserving energy.

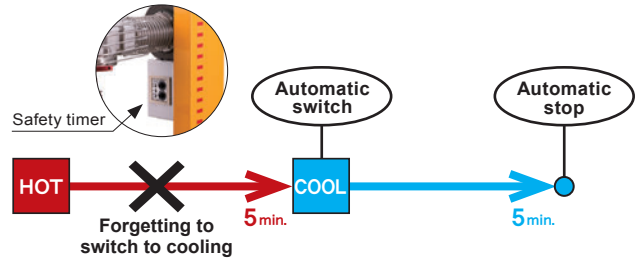

Even if you forget to switch to cooling operation, this unit automatically switches to the cooling operation 5 minutes after the heating operation started to prevent overheating problems.

Baby 1200S



Max. Cutter dia.
φ3~12 [1/8~1/2"]

Rated power consumption
1200w

Cutter dia. φ6
Heating **120 sec.**

CODE	Area	Size (W×D×H)	Rated voltage	kg
HRB-02S	Japan	370×260×590mm	100 v	8.0
-02S-120NA	North America		120 v	

Option

- Please choose parts on P.15-17.

Std. Access.

- Timer •Heat-resistant gloves •Tweezers

Note

- Some holders cannot be used.(P.15)

Baby 1000



Max. Cutter dia.
φ3~12 [1/8~1/2"]

Rated power consumption
1000w

Cutter dia. φ6
Heating **180 sec.**

CODE	Area	Size (W×D×H)	Rated voltage	kg
HRB-01	Japan	340×160×410mm	100 v	3.5

Option

- Please choose parts on P.15-17.

Std. Access.

- Adapter (ADH-SLK) •Timer •Nozzles, 2 pieces (HNZ-17, HNZ-22)
- Heat-resistant gloves •Tweezers

Note

- A transformer is required in other voltage. Please consult MST about the details of the transformer.

Option

■ Base

CODE
BAA-01

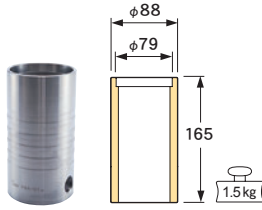

Examples of typical uses

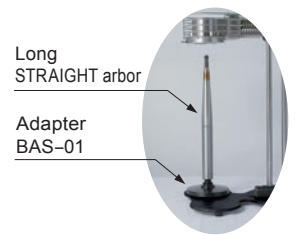
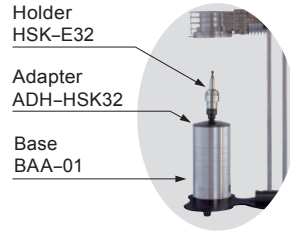
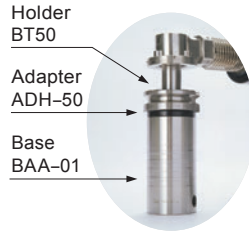

■ Adapter

CODE	Dimensions	Holder		Shrink-Fit Heater model for Use						
		Type	Screw size	HRD-02SH	HRD-03	HRD-01S	HRB-03S	HRB-02S	HRB-01	
ADH-SLK		2 PIECE type SLIMLINE collet	6 type	M6	○	○	○	○	○	○
			8 type	M6						
			12 type	M10						
			ST10	M6						
			ST12	M8						
		STRAIGHT arbor	ST16/20/25	M10						
ADH-HSK25		MONO 3° MONO CURVE UNO HYPER VERSION	E25		○	△	△	○	△	×
-HSK32			E32							
-HSK40E			E40							
-HSK40A			A40							
-HSK50			A50 / E50 / F63							
-40			BT40 / A63 F63 / F80 / F80PD DN40 / CT40							
-50			BT50 / A100 DN50 / CT50							
-15TR			15TR3							
-S20TR			RS20 / S20TR							
-BT30			BT30							
BAS-01		STRAIGHT arbor	ST16/20/25	M10	○	△	△	○	○	×
			ST32	M16						
			ST42	M24						
-02			Carbide Shank ST○○C							

[○]: Available

[×]: Not available

[△]: Restricted use

Cutter Stopper

Used as a stopper in the holder when shrink fitting or removing a cutting tool.

HSA_{type} (Coil Spring Type)

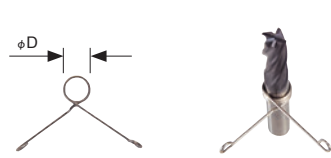

CODE	φD	Set Contents(Q'ty)
HSA-D [Ex : HSA-6]	3, 3.175 [1/8"], 4, 5, 6, 7, 8, 9, 10, 11, 12, 16, 20, 25, [3/16", 1/4", 5/16", 3/8", 1/2"]	Each size 10 ea. /SET
-E	3, 4, 6, 8, 10, 12	1 ea., 6 pieces in total
-F	3, 4, 5, 6, 7, 8, 9, 10, 11, 12	1 ea., 10 pieces in total
-EF	3, 4, 5, 6, 8, 10, 12, 16, 20, 25	1 ea., 10 pieces in total

HSB_{type} (Plate Spring Type)

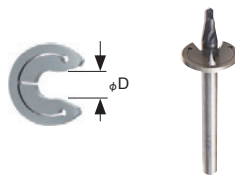

CODE	φD	Set Contents(Q'ty)
HSB-D [Ex : HSB-6]	3, 3.175 [1/8"], 4, 5, 6, 7, 8, 9, 10, 11, 12, 16, 20, 25, 32, [3/16", 1/4", 5/16", 3/8", 1/2", 5/8", 3/4", 1"]	1 ea.
-E	3, 4, 6, 8, 10, 12	1 ea., 6 pieces in total
-F	3, 4, 5, 6, 7, 8, 9, 10, 11, 12	1 ea., 10 pieces in total
-EF	3, 4, 5, 6, 8, 10, 12, 16, 20, 25	1 ea., 10 pieces in total

HSC_{type} (Slit Collet Type)

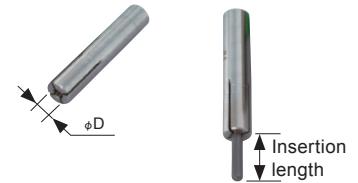

CODE	φD
HSC-D [Ex : HSC-6]	3, 3.175 [1/8"], 4, 6



Caution

•HSA type cannot be used with HEAT ROBO DENJI.

Insertion

Adjust cutting tool projection or insertion length.

The cutter shank should exceed the safety mark.

Removing

Leave some clearance, and attach the stopper.

Ready to remove!

Cutter Pliers

Heat-resistant gloves are not required to perform the simple shrink-fit operation.

CODE
HPY-01

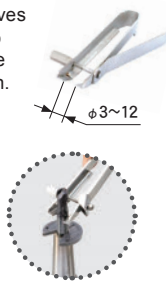

Stopper Pliers

Easy to attach and detach for HSB type.

CODE
SPY-01

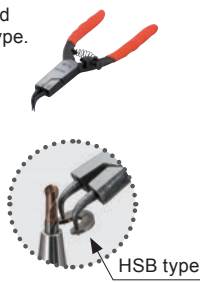

Cutter Adjuster

Simply adjustment for cutting tool projection and insertion length.

CODE	φD	L
HAJ-3	3	10~ 30
-3.175	3.175 [1/8"]	
-4	4	13~ 30
-3/16	[3/16"]	
-6	6	19~ 45
-1/4	[1/4"]	
-8	8 [5/16"]	21~ 55
-10	10 [3/8"]	22~ 70
-12	12	23~ 85
-1/2	[1/2"]	
-16	16 [5/8"]	26~ 90
-20	20 [3/4"]	37~100
-25	25	40~100
-1"	[1"]	

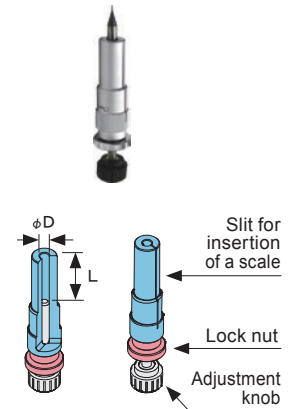

Cutter Tray

Cooling Tray for heated cutting tools after removal from a holder.

CODE
SDH-01

Size:170×170 (mm)



Heat-resistant gloves

For additional order

CODE	NOTE
HTB-01	—
-01-R	Right Hand
-01-L	Left Hand



Holder Stand

The stand for the SLIMLINE collet, straight arbor and small shank holders (HSK-E25 and E32) is available in four colors, enabling simple color-coding.

CODE	Color	Front face	Back face	max. Q'ty
SDKT-RE	RED			25 pieces each
-BL	BLUE	SLIMLINE collet	Small shank holders (HSK-E25 / E32)	
-GR	GREEN	STRAIGHT arbor		
-GD	GOLD			

Size:190×190 (mm)



Use HSB to set cutting tool projection length, for regular cutters.

Stopper(HSB type) (Thickness : 2mm)

L+2mm (Cutter projection)

- Scale
- Lock nut
- HSB
- Fixing

Use HSC to set cutting tool projection length, for tapered neck cutters.

Stopper (HSC type)

L (Insertion length)

- Scale
- Lock nut
- More than 2mm
- Fixing

Cover the tool tip with the stopper

■ Cleaning tools

■ Brush type

Nylon brushes for internal bores cleaning.

CODE	I.D
AQC-BR -SET	3 [1/ 8"], 4 [3/16"], 6 [1/4"], 8 [5/16"], 10 [3/ 8"], 12 [1/2"], 1 of each. 6 pieces in total
-BR 3-5	3 [1/ 8"], 5 pcs.
-BR 4-5	4 [3/16"], 5 pcs.
-BR 6-5	6 [1/ 4"], 5 pcs.
-BR 8-5	8 [5/16"], 5 pcs.
-BR10-5	10 [3/ 8"], 5 pcs.
-BR12-5	12 [1/ 2"], 5 pcs.

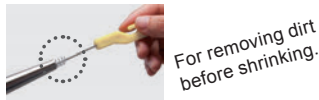

■ **Caution**
• Do not use when holder is hot.

■ Rubber grinding stone type

To eliminate strong oxidized film and burned-in dust and oil that have been generated in the internal bores.

Standard set

CODE	NOTE
CLT-GTA-01	1 ea. of right model

Parts

CODE	NAME	φd	Q'ty
CLT-GTA-GP	Grip	—	1
-GTA 3-5	Rubber grindstone	3	5
-GTA 4-5		4	5
-GTA 6-5		6	5
-GTA 8-5		8	5
-GTA10-5		10	5

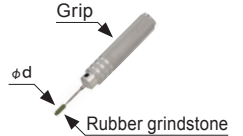
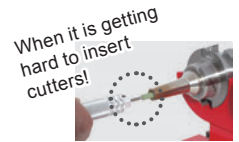

■ Aqua Cool

■ Aqua cool kit

Cooling kit for cooling SLIMLINE holders after shrink fitting or removing.

CODE	NOTE
AQC-KIT-01	1 ea. for below model

Parts

CODE	NAME	NOTE
AQC-EK-01-2	Special Liquid	2l of undiluted Solution, Use at a dilution ratio of 3%.
-AT-01	Aqua Tray	Drainer plate
-AH-01	Adapter Hanger	Hanger for lowering holders into liquid.
CN -245	Container Box	Size:424×291×245 (364×242×230) mm
-FT	Lid for Container Box	Size:421×288×35 mm

() inside dimension

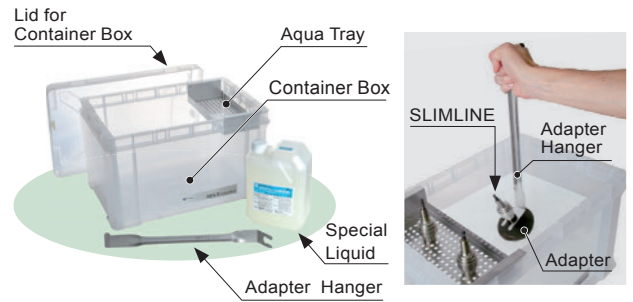

■ A shrink-fitting work efficiency kit, Shrink-fit holder Chiller

Shrink fitting operation can be shortened. Installation is easy as no power supply is required. All MST's heating devices are available.

■ Shrink-fit holder Chiller A type For Induction Heaters and Hot Air Heaters

CODE	Cooling tower	kg
CWBA01	1 pc.	18
CWBA02	2 pcs.	25

■ Std. Access.

- Slide table
- Slide type base(3 pcs.)
- Stopper ring(6 pcs.)
- Thermo seal(7 pcs.)
- Connecting air tube (dia.8mm, length 2m)

■ Note

- Compressed air required: 0.5MPa (air-consumption volume: 245 l/min)
- Please connect the air line that came with the unit. (Supply air pressure: 0.5~0.7MPa)

CWBA01

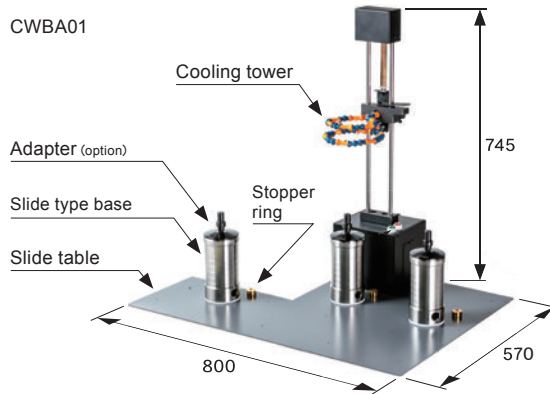

CWBA02

(Installed 2 cooling towers)

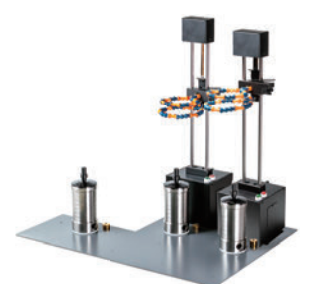

REPLACEMENT PARTS

Cooling tower (For additional orders)

CODE	kg
CTW01	



Slide table

CODE	kg
SLT01	



Slide type base

CODE	kg
BAA-01SL	



Stopper ring

CODE	Q'ty
SRG01	2



Thermo seal

CODE	Q'ty
THR60	7

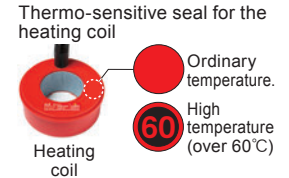

■ Shrink-fit holder Chiller B type

Compact type that can be installed in tight spots.

CODE	kg
CWBB01	7.3

■ Std. Access.

- Thermo seal(7 pcs.)
- Connecting air tube (dia.8mm, length 2m)

■ Note

- Compressed air required : 0.5MPa (air-consumption volume : 245l/min)
- Please connect the air line that came with the unit. (Supply air pressure : 0.5~0.7MPa)

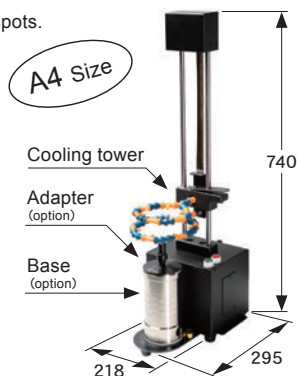

■ Shrink-fit holder Chiller C type For Hot Air Heaters

For HEAT ROBO Baby 3000S/1200S.

CODE	kg
CWBC01	7.2

■ Note

- Compressed air required : 0.5MPa (air-consumption volume : 245 l/min)
- Prepare an air tube (O.D. : 8mm) and a connection coupling.

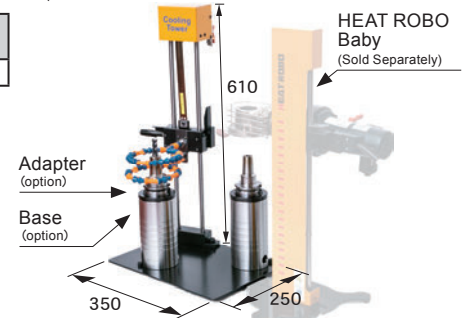

MONO SERIES

MONO 3°

■ An amazing line-up for all kinds of applications.

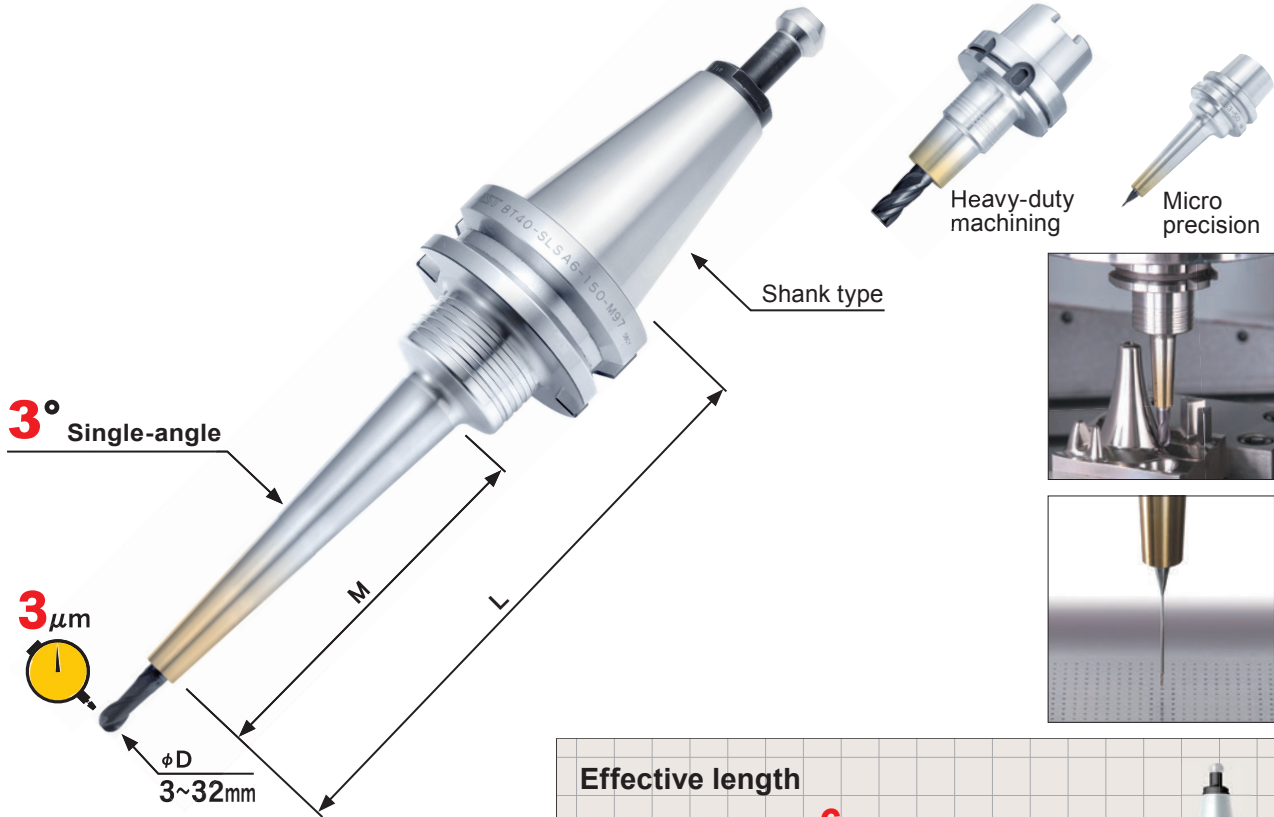

3,000
variations

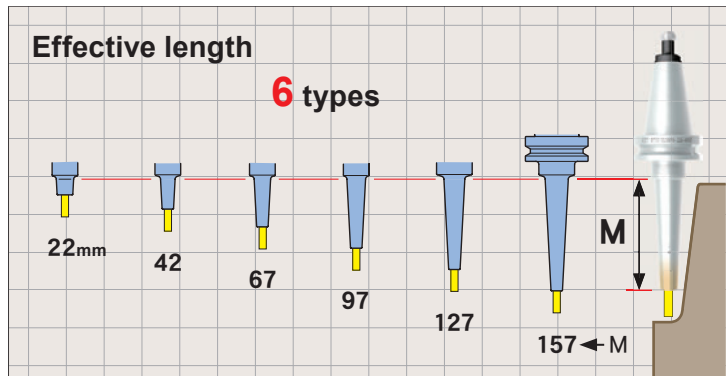

BT50 - SL SA 3 - 110 - M42

PAGE	Shank Type
20	BT30
23	BT40
47	BT50
70	A40
74	A50
78	A63
111	A100
140	E25
142	E32
146	E40
153	E50
163	F63
180	15T
181	S20T
182	RS20

● DIN and CAT. shank products are available upon request.

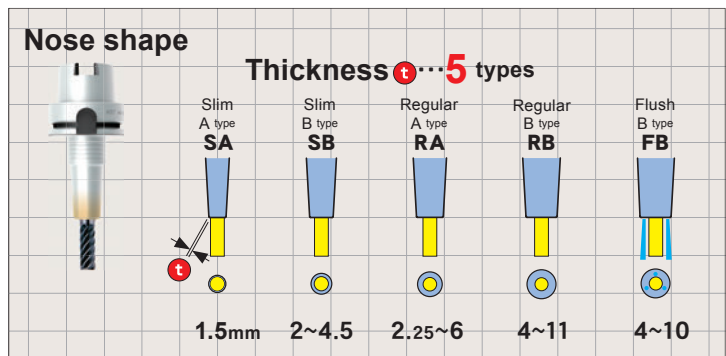
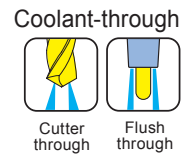
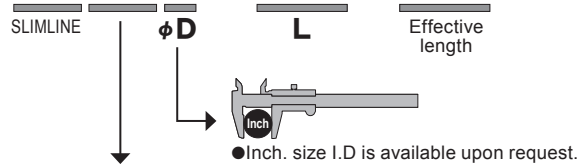

MONO CURVE

■ The slim tip and thick base provide great rigidity even in long holders.

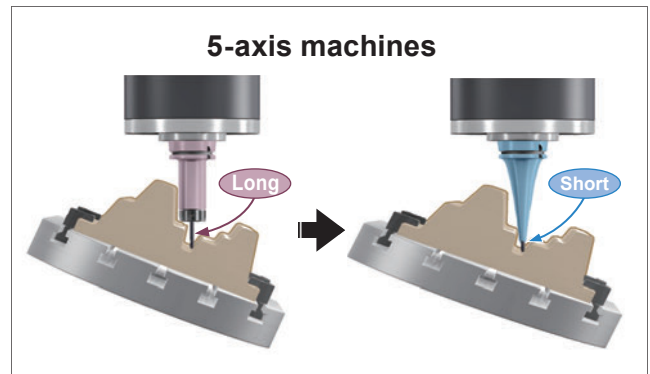
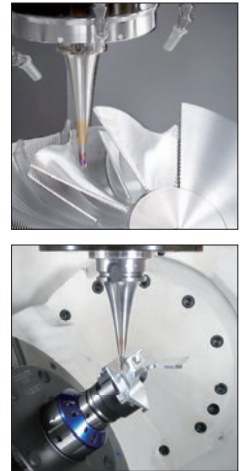
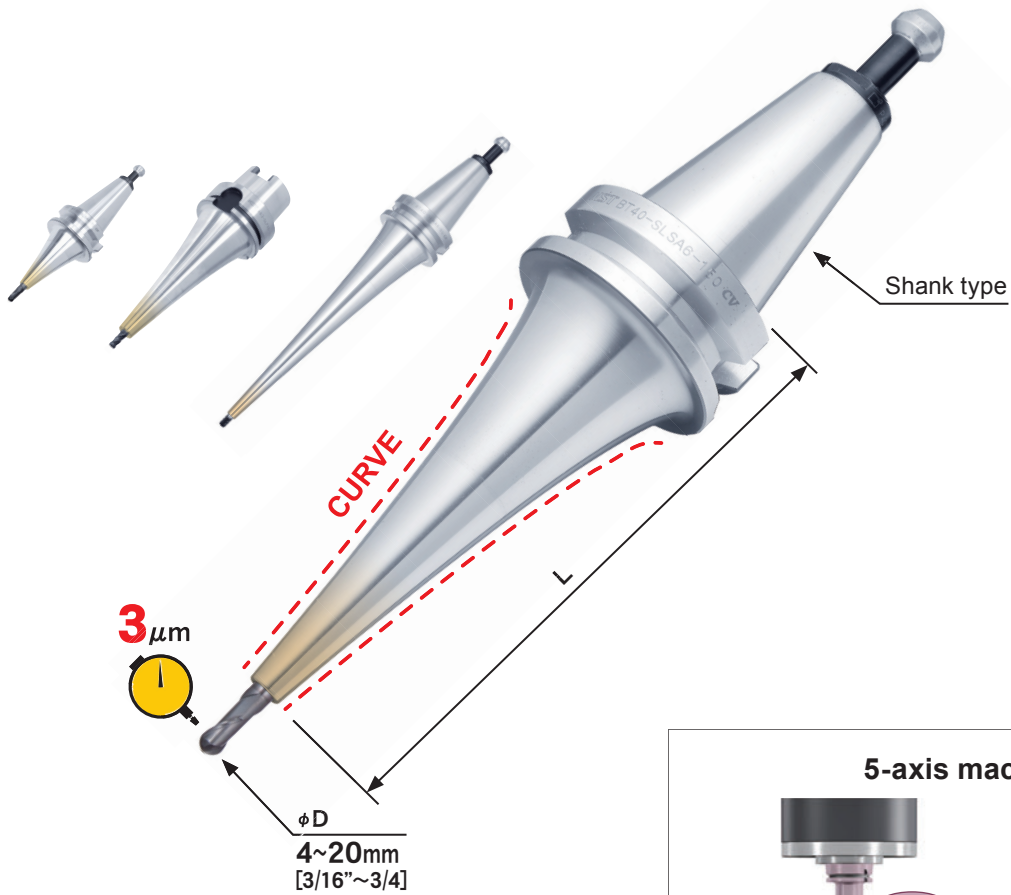

500
variations

BT50 - SL SA 4 - 165 CV

Shank Type SLIMLINE ϕD L CURVE

PAGE		Inch
20	BT30	—
23	BT40	—
47	BT50	—
74	A50	○
78	A63	○
111	A100	○
142	E32	○
146	E40	○
153	E50	○
163	F63	○
183	CT50	○

Coolant-through

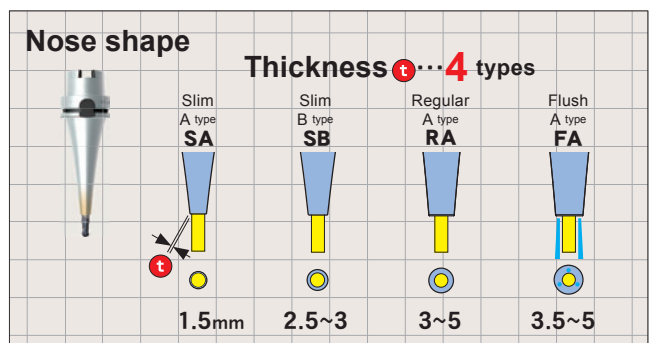
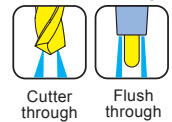

● DIN shank products are available upon request.

BT30

MONO 3°

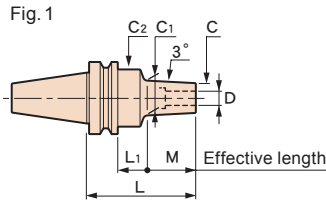

MONO CURVE

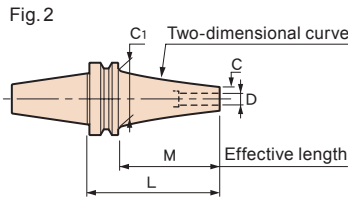
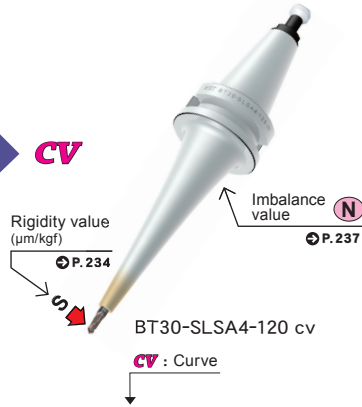

Option

- Retention knob → P.216

Caution

- Retention knob... Use a retention knob with hole, or remove the retention knob and heat it.
- Setting cutters... Be sure to insert the tool beyond the safety mark.

CODE	Fig.	φD	φC	t	L	M	L1	φC1	φC2	H	h	Kg	N	S	Scale model		
BT30-SLSA3- 75-M22	1	3	6	1.5	75	22	31	8.3	25	9	99	0.4	0.8	4.6	2		
- 95-M42					95	42		10.4			119				9.2	3	
-120-M67					120	67		13			144				0.5	1.6	14.9
-SLRA3- 75-M22	1	3	7.5	2.25	75	22	31	9.8	25	9	99	0.5	1.6	2.8	5		
BT30-SLSA3.175-75-M22	1	3.175	6.175	1.5	75	22	31	8.5	25	9	99	0.4	0.8	4.4	6		
-95-M42					95	42		10.6			119				8.8	7	
BT30-SLSA4- 75-M22	1	4	7	1.5	75	22	31	9.3	25	12	99	0.4	0.8	3.6	8		
- 95-M42					95	42		11.4			119				7.3	9	
-120-M67					120	67		14			144				0.5	1.6	11.9
-SLRA4- 75-M22	1	4	10	3	75	22	31	12.3	25	12	99	0.5	1.6	1.8	11		
-SLSA4- 75 cv	2	4	7	1.5	75	53	—	34	—	12	99	0.5	1	1.8	12		
- 90 cv					90	68					114				1.1	2.8	13
-120 cv					120	98					144				1.2	6.6	14
-SLRA4- 90 cv	2	4	10	3	90	68	—	34	—	12	114	0.5	1	2	15		
-120 cv					120	98					144				1.1	2.9	16
BT30-SLSA6- 75-M22	1	6	9	1.5	75	22	31	11.3	25	18	99	0.4	0.9	2.4	17		
- 95-M42					95	42		13.4			119				4.9	18	
-120-M67					120	67		16			144				0.5	1.7	8.3
-SLRA6- 75-M22	1	6	12	3	75	22	31	14.3	25	18	99	0.4	0.9	1.4	20		
-SLSA6- 75 cv	2	6	9	1.5	75	53	—	34	—	18	99	0.5	1.3	1.5	21		
- 90 cv					90	68					114				1	2.4	22
-120 cv					120	98					144				1.2	5.6	23
-SLRA6- 90 cv	2	6	13	3.5	90	68	—	34	—	18	114	0.5	1.1	1.6	24		
-120 cv					120	98					144				1.2	2.5	25
BT30-SLRA8- 75-M22	1	8	14	3	75	22	31	16.3	25	24	99	0.4	0.9	1.2	26		
-SLSA8- 75 cv	2	8	11	1.5	75	53	—	34	—	24	99	0.5	1.1	1.3	27		
- 90 cv					90	68					114				0.6	1.6	2.2
-SLRA8- 90 cv	2	8	16	4	90	68	—	34	—	24	114	0.5	1.2	1.1	29		

CODE	Fig.	φD	φC	t	L	M	L ₁	φC ₁	φC ₂	H	h	Kg	N	S	Scale model
BT30-SLRA10- 75-M22	1	10	16	3	75	22	31	18.3	25	30	99	0.4	1	1.1	30
-SLSA10- 75 CV	2	10	13	1.5	75	53	—	34	—	30	99	0.5	1.6	1.2	31
- 90 CV					90	68					114		1.4	2	32
-SLRA10- 90 CV	2	10	19	4.5	90	68	—	34	—	30	114	0.6	1.5	1.1	33
BT30-SLRA12- 75-M22	1	12	20	4	75	22	31	22.3	25	30	99	0.5	1.2	1	34
BT30-SLRA16- 60-M22	1	16	26	5	60	22	16	28.3	34	32	60	0.5	1.6	0.5	35
BT30-SLRA20- 65-M22	1	20	32	6	65	22	21	34.3	40	38	60	0.6	2.1	0.4	36

■ Cleaning tool for a spindle taper hole, STAR DUST

CODE
CLT-NT30-G2

☎ P.226



S=1:5

φ3

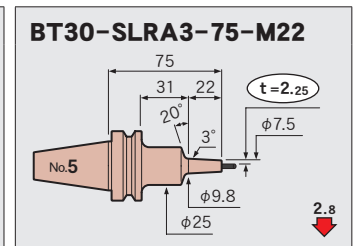
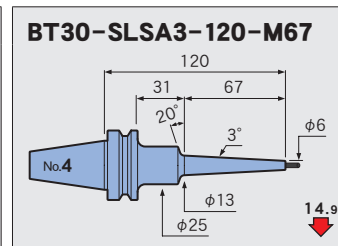
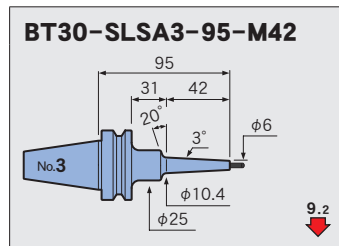
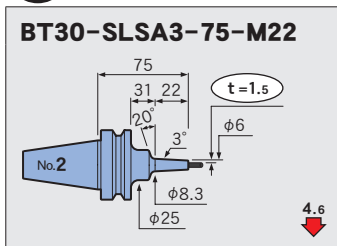

φ3.175

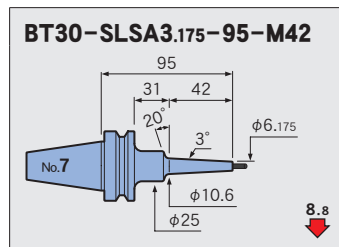
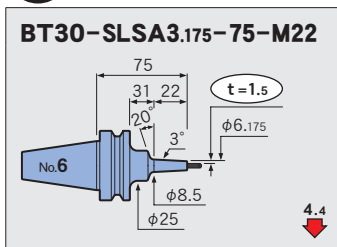

φ4

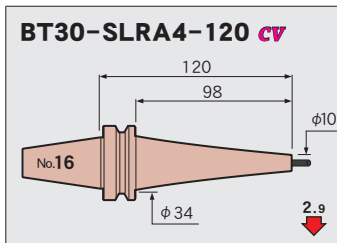
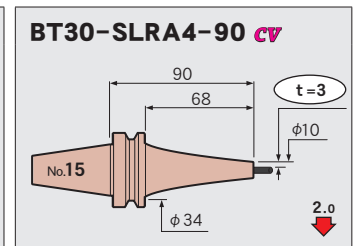
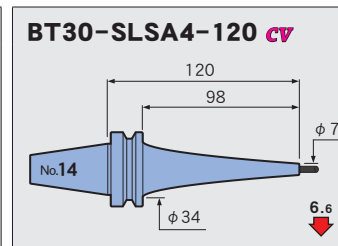
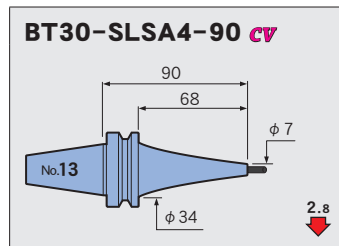
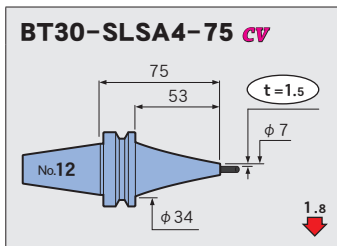
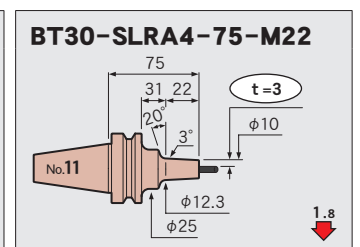
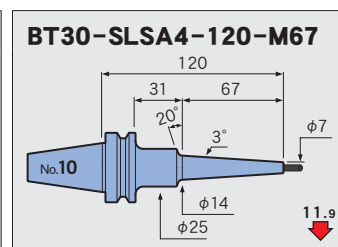
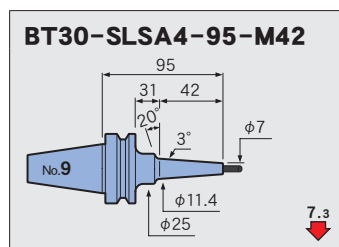
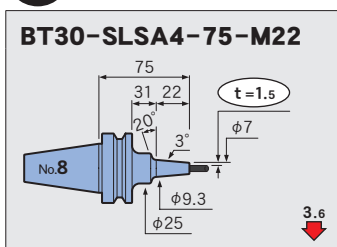

φ6

BT30-SLSA6-75-M22

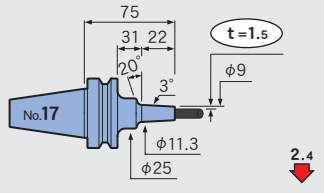

BT30-SLSA6-95-M42

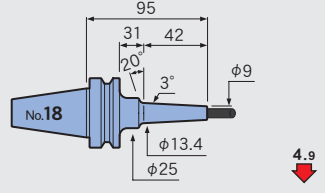

BT30-SLSA6-120-M67

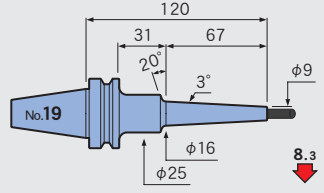

BT30-SLRA6-75-M22

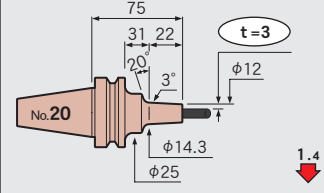

BT30-SLSA6-75 CV

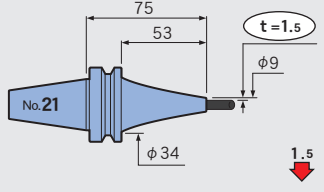

BT30-SLSA6-90 CV

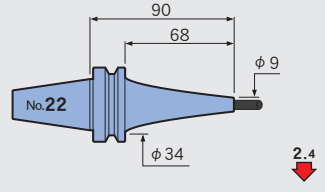

BT30-SLSA6-120 CV

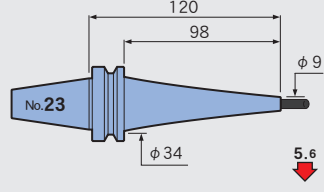

BT30-SLRA6-90 CV

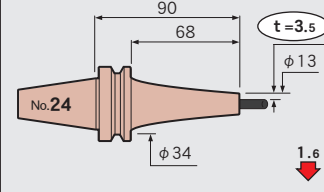

BT30-SLRA6-120 CV

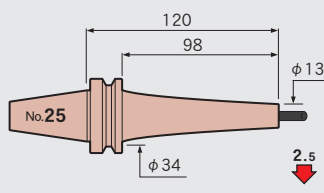

φ8

BT30-SLRA8-75-M22

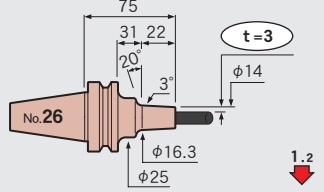

BT30-SLSA8-75 CV

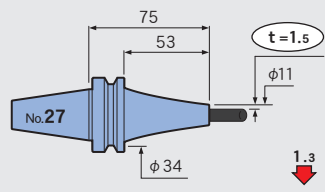

BT30-SLSA8-90 CV

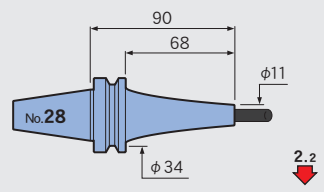

BT30-SLRA8-90 CV

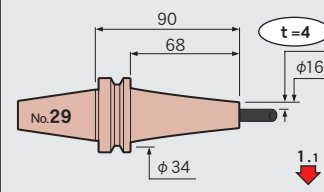

φ10

BT30-SLRA10-75-M22

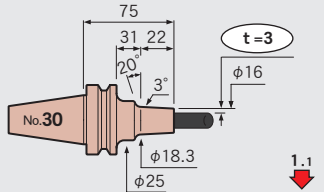

BT30-SLSA10-75 CV

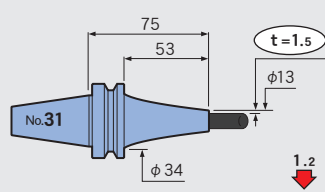

BT30-SLSA10-90 CV

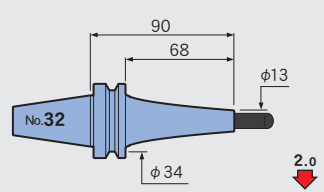

BT30-SLRA10-90 CV

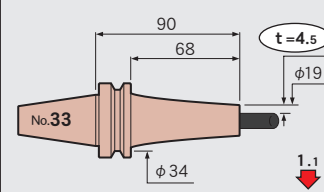

φ12

BT30-SLRA12-75-M22

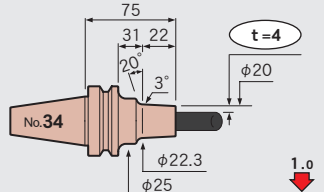

φ16

BT30-SLRA16-60-M22

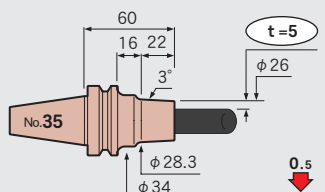

φ20

BT30-SLRA20-65-M22

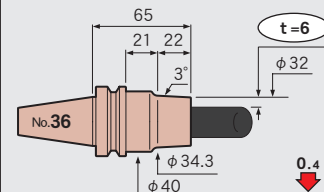

Feature

Shrink-fit Heater

MONO 3°
MONO CURVE

MONO Series

2PIECE type

UNO

HYPER
version

STRAIGHT
anbor

OTHERS

PERIPHERALS

Technical
Information

BT40

MONO 3°



MONO CURVE CV

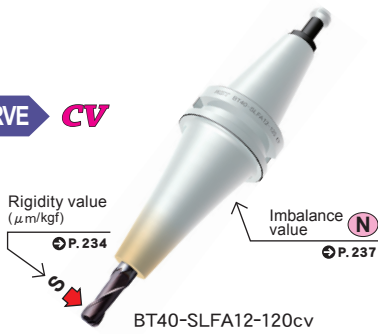

CV : Curve

Thickness

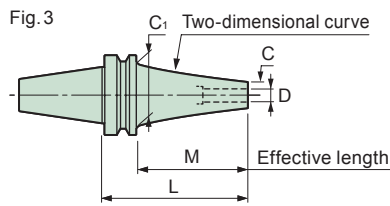
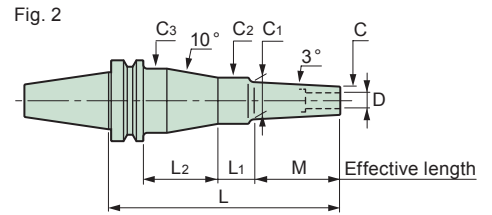
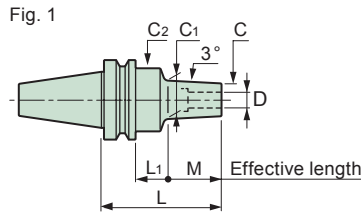

Option

- Retention knob → P.216

Caution

- Retention knob... Use a retention knob with hole, or remove the retention knob and heat it.
- Setting cutters... Be sure to insert the tool beyond the safety mark.

Safety mark

Thickness t

H Clamping length



h Max. insertion length

Compatibility table for HRD-01S

[○] Available [x] Not available

[▲] Usable by raising the heating unit. → P.233











































CODE	Fig.	ϕD	ϕC	t	L	M	L ₁	L ₂	ϕC_1	ϕC_2	ϕC_3	H	h	Kg	N	S	Scale model				
BT40-SLSA3- 95-M 42	1	3	6	1.5	95	42	26	—	10.4	25	—	9	130	1	2.3	9.1	○				
-120-M 67					120	67	—	13	—	—	—	—	—	—	155	—	3.1	14.6	○		
-125-M 42					125	42	56	10.4	—	—	—	—	—	—	160	1.1	2.5	9.7	○		
-150-M 67					150	67	—	13	—	—	—	—	—	—	185	—	3.2	15.7	○		
-M 97					97	26	—	16.2	—	—	—	—	—	—	—	—	4	20.4	○		
-155-M 42	2	3	6	1.5	155	42	33	53	10.4	26	40	9	190	1.4	2.7	9.9	○				
-180-M 67					180	67	—	13	25	39	215	—	—	—	—	3.4	15.7	○			
-M 97	1	3	6	1.5	—	97	56	—	16.2	—	—	—	—	1.2	4.1	22.1	○				
-210-M 97	2	3	6	1.5	210	—	33	53	—	—	39	—	245	1.4	4.3	22.1	○				
-SLRA3- 75-M 22	1	3	7.5	2.25	75	22	26	—	9.8	25	—	9	110	1	2.6	2.7	○				
- 95-M 42					95	42	—	11.9	—	—	—	—	—	—	130	—	2.9	5.3	○		
-105-M 22					105	22	56	9.8	—	—	—	—	—	—	140	1.1	2.7	3.2	○		
-120-M 67					120	67	26	14.5	—	—	—	—	—	—	155	—	3.4	8.8	○		
-125-M 42					125	42	56	11.9	—	—	—	—	—	—	160	—	3	6	○		
-135-M 22					2	3	7.5	2.25	135	22	33	53	9.8	—	39	9	170	1.4	2.9	3.2	○
-150-M 67					1	3	7.5	2.25	150	67	56	—	14.5	—	—	9	185	1.2	3.5	14.5	○
-M 97									97	26	—	17.7	—	—	—	—	—	—	—	1.1	4.1
-155-M 42					2	3	7.5	2.25	155	42	33	53	11.9	—	39	9	190	1.4	3.2	6	○
-180-M 67									180	67	—	14.5	26	40	215	—	—	—	—	3.7	9.8
-M 97	1	3	7.5	2.25	97	56	—	—	17.7	25	—	9	—	1.2	4.2	14.3	○				
-M127					127	26	—	20.8	36	—	—	—	—	—	—	1.1	5.4	15.7	○		
-210-M 97	2	3	7.5	2.25	210	97	33	53	17.7	25	39	9	245	1.5	4.4	14.4	○				
-M127	1	3	7.5	2.25	—	127	56	—	20.8	32	—	9	—	1.4	5.5	16.5	○				
-240-M127	2	3	7.5	2.25	240	—	28	58	—	36	50	9	275	1.8	5.8	16.3	○				

CODE	Fig.	ϕD	ϕC	t	L	M	L ₁	L ₂	ϕC_1	ϕC_2	ϕC_3	H	h	Kg	N	S	Scale model
BT40-SLFB3- 75-M 22	1	3	9.5	3.25	75	22	26	—	11.8	25	—	9	110	1	2.4	1.9	25
 - 95-M 42					95	42			13.9				130		2.7	3.2	28
-105-M 22					105	22	56		11.8				140	1.1	2.5	2.3	26
-120-M 67					120	67	26		16.5				155		3.4	5.3	31
-125-M 42					125	42	56		13.9				160		2.8	3.9	29
-135-M 22	2				135	22	33	53	11.8		39		170	1.4	2.7	2.3	27
-150-M 67	1				150	67	56	—	16.5		—		185	1.2	3.6	6.4	32
-155-M 42	2				155	42	33	53	13.9		39		190	1.4	3	3.9	30
-180-M 67					180	67			16.5	26	40		215		3.8	6.3	33
BT40-SLSA4- 95-M 42	1	4	7	1.5	95	42	26	—	11.4	25	—	12	130	1	3.1	7.1	34
-120-M 67					120	67			14				155			11.7	37
-125-M 42					125	42	56		11.4				160	1.1	3.3	7.9	35
-150-M 67					150	67			14				185			12.8	38
BT40 -M 97						97	26		17.2						4.1	16.5	40
-155-M 42	2				155	42	33	53	11.4		39		190	1.4	3.5	7.9	36
-180-M 67					180	67			14				215			12.8	39
-M 97	1					97	56	—	17.2		—			1.2	4.2	18.3	41
-210-M 97	2				210		33	53			39		245	1.5	4.4	18.2	42
-SLRA4- 75-M 22	1	4	10	3	75	22	26	—	12.3	25	—	12	110	1	2.7	1.7	43
- 95-M 42					95	42			14.4				130		3.1	3.1	46
-105-M 22					105	22	56		12.3				140	1.1	2.8	2.2	44
-120-M 67					120	67	26		17				155		3.9	5.1	49
-125-M 42					125	42	56		14.4				160		3.3	3.8	47
-135-M 22	2				135	22	33	53	12.3		39		170	1.4	3	2.2	45
-150-M 67	1				150	67	56	—	17		—		185	1.2	4	6.3	50
-M 97						97	26		20.2					1.1	4.8	7.7	52
-155-M 42	2				155	42	33	53	14.4		39		190	1.4	3.5	3.8	48
-180-M 67					180	67			17				215		4.2	6.2	51
-M 97	1					97	56	—	20.2		—			1.2	4.9	9.5	53
-M127					127	26			23.3	32					6.8	9.4	55
-210-M 97	2				210	97	33	53	20.2	25	39		245	1.5	5.1		54
-M127	1					127	56	—	23.3	32	—			1.4	7	10.3	56
-240-M127	2				240		30	56			46		275	1.8	7.3	10.4	57
-SLFB4- 75-M 22	1	4	12	4	75	22	26	—	14.3	25	—	12	110	1	2.5	1.3	58
 - 95-M 42					95	42			16.4				130	1.1	3	2.2	61
-105-M 22					105	22	56		14.3				140		2.7	1.8	59
-120-M 67					120	67	26		19				155		3.8	3.5	64
-125-M 42					125	42	56		16.4				160	1.2	3.1	2.9	62
-135-M 22	2				135	22	33	53	14.3		39		170	1.4	2.9	1.8	60
-150-M 67	1				150	67	56	—	19		—		185	1.2	4	4.7	65
-155-M 42	2				155	42	33	53	16.4		39		190	1.4	3.3	2.9	63
-180-M 67					180	67			19				215	1.5	4.2	4.7	66
-SLSA4- 90 CV	3	4	7	1.5	90	63	—	—	53	—	—	12	125	1.2	3.3	1.8	67
-120 CV					120	93							155	1.3	3.8	2.7	68
-150 CV					150	123							185	1.5	4.4	4	69
-180 CV					180	153							215		4.8	6.6	70
-210 CV					210	183							245	1.6	4.9	11.6	71
-240 CV					240	213							275	1.8	5.8	14	72
-SLRA4-120 CV	3	4	10	3	120	93	—	—	53	—	—	12	155	1.3	3.9	1.9	73
-150 CV					150	123							185	1.4	4.3	2.9	74
-180 CV					180	153							215	1.5	5.1	4.2	75
-210 CV					210	183							245	1.7	5.7	5.7	76

CODE	Fig.	φD	φC	t	L	M	L ₁	L ₂	φC ₁	φC ₂	φC ₃	H	h	Kg	N	S	Scale model	Feature
BT40-SLSA6- 95-M 42	1	6	9	1.5	95	42	26	—	13.4	25	—	18	130	1	3.3	4.8	○	77
-120-M 67					120	67			16				155	1.1	4.4	8		80
-125-M 42					125	42	56		13.4				160		3.5	5.6		78
-150-M 67					150	67			16				185	1.2	4.5	9.2		81
-M 97						97	26		19.2	32				1.1	5.9	11		83
-155-M 42	2				155	42	33	53	13.4	25	39		190	1.4	3.7	5.6		79
-180-M 67					180	67			16				215		4.7	9.2		82
-M 97	1					97	56	—	19.2	32	—			1.3	6.1	11.7		84
-210-M 97	2				210		30	56			46		245	1.7	6.4			85
-SLSB6- 95-M 42	1	6	10	2	95	42	26	—	14.4	25	—	18	130	1	4	3.6	○	86
-120-M 67					120	67			17				155	1.1	5.4	6.1		89
-125-M 42					125	42	56		14.4				160		4.1	4.5		87
-150-M 67					150	67			17				185	1.2	5.5	7.4		90
-M 97						97	26		20.2	32					7.2	8.5		92
-155-M 42	2				155	42	33	53	14.4	25	39		190	1.4	4.3	4.4		88
-180-M 67					180	67			17				215		5.7	7.4		91
-M 97	1					97	56	—	20.2	32	—			1.3	7.4	9.2		93
-M127						127	26		23.3					1.2	8.9	11		95
-210-M 97	2				210	97	30	56	20.2		46		245	1.7	7.7	9.2		94
-M127	1					127	56	—	23.3		—			1.4	9.1	12		96
-M157						157	26		26.5					1.3	10.6	13.2		98
-240-M127	2				240	127	30	56	23.3		46		275	1.8	9.4	12		97
-M157	1					157	56	—	26.5	36	—			1.7	10.8	14.5		99
-270-M157	2				270		30	56		32	46		305	1.9	11	14.6	▲	100
-SLRB6- 75-M 22	1	6	14	4	75	22	26	—	16.3	32	—	18	110	1.1	3.2	1	○	101
- 95-M 42					95	42			18.4				130		4.3	1.6		104
-105-M 22					105	22	56		16.3				140	1.2	3.3	1.2		102
-120-M 67					120	67	26		21				155		5.6	2.6		107
-125-M 42					125	42	56		18.4				160	1.3	4.4	1.9		105
-135-M 22	2				135	22	30	56	16.3		46		170	1.6	3.6	1.2		103
-150-M 67	1				150	67	56	—	21		—		185	1.3	5.8	3		108
-155-M 42	2				155	42	30	56	18.4		46		190	1.6	4.7	1.9		106
-180-M 67					180	67			21				215	1.7	6.1	3.1		109
-SLFB6- 75-M 22	1	6	14	4	75	22	26	—	16.3	32	—	18	110	1.1	3.2	1	○	110
- 95-M 42					95	42			18.4				130		4.3	1.6		113
-105-M 22					105	22	56		16.3				140	1.2	3.3	1.2		111
-120-M 67					120	67	26		21				155		5.6	2.6		116
-125-M 42					125	42	56		18.4				160	1.3	4.4	1.9		114
-135-M 22	2				135	22	30	56	16.3		46		170	1.6	3.6	1.2		112
-150-M 67	1				150	67	56	—	21		—		185	1.3	5.8	3		117
-155-M 42	2				155	42	30	56	18.4		46		190	1.6	4.7	1.9		115
-180-M 67					180	67			21				215	1.7	6.1	3.1		118
-SLSA6- 90 CV	3	6	9	1.5	90	63	—	—	53	—	—	18	125	1.2	3.3	1.6	○	119
-120 CV					120	93							155	1.3	3.8	2.3		120
-150 CV					150	123							185	1.5	4.3	3.6		121
-180 CV					180	153							215		4.9	5.7		122
-210 CV					210	183							245	1.7	5.7	7.3		123
-240 CV					240	213							275	1.8	5.9	12		124
-SLRA6- 90 CV	3	6	13	3.5	90	63	—	—	53	—	—	18	125	1.2	3.3	1.2	○	125
-120 CV					120	93							155	1.3	4	1.7		126
-150 CV					150	123							185	1.5	4.8	2.1		127
-180 CV					180	153							215	1.7	5.6	2.8		128
-210 CV					210	183							245		5.9	4.8		129
-SLFA6- 90 CV	3	6	13	3.5	90	63	—	—	53	—	—	18	125	1.2	3.3	1.2	○	130
-120 CV					120	93							155	1.3	4	1.7		131
-150 CV					150	123							185	1.5	4.8	2.1		132
-180 CV					180	153							215	1.7	5.6	2.8		133
-210 CV					210	183							245		5.9	4.8		134

BT40







CODE	Fig.	ϕD	ϕC	t	L	M	L ₁	L ₂	ϕC_1	ϕC_2	ϕC_3	H	h	 Kg	 N	 S		Scale model
BT40-SLSA8- 95-M 42	1	8	11	1.5	95	42	26	—	15.4	25	—	24	130	1	4.6	3.4		135
-120-M 67					120	67	—	18	32	—	155	1.1	6.3	5.4		138		
-125-M 42					125	42	56	15.4	25	—	160	—	4.7	4.3		136		
-150-M 67					150	67	—	18	32	—	185	1.3	6.5	5.9		139		
-M 97					—	97	26	21.2	—	—	—	—	1.2	8.4	7.9		141	
-155-M 42					2	155	42	33	53	15.4	25	39	190	1.4	5	4.3		137
-180-M 67						180	67	30	56	18	32	46	215	1.6	6.7	5.9		140
-M 97					1	—	97	56	—	21.2	—	—	—	1.3	8.6	8.7		142
-210-M 97					2	210	—	28	58	—	36	50	245	1.9	8.8	8.4		143
-SLSB8- 95-M 42	1	8	13	2.5	95	42	26	—	17.4	32	—	24	130	1.1	5.3	2.1		144
-120-M 67					120	67	—	20	—	—	155	—	7.4	3.5		147		
-125-M 42					125	42	56	17.4	36	—	160	1.3	5.5	2.3		145		
-150-M 67					150	67	—	20	32	—	185	—	7.6	4		148		
-M 97					—	97	26	23.2	—	—	—	—	1.2	10	5.2		150	
-155-M 42					2	155	42	30	56	17.4	—	46	190	1.6	5.7	2.5		146
-180-M 67						180	67	—	20	—	215	1.7	7.9	4		149		
-M 97					1	—	97	56	—	23.2	—	—	1.4	10.2	6		151	
-M127					—	127	26	26.3	—	—	—	—	1.3	12.6	7		153	
-210-M 97	2	210	97	30	56	23.2	—	46	245	1.7	10.4	6		152				
-M127	1	—	127	56	—	26.3	32	—	1.4	12.7	8.1		154					
-M157	—	157	26	29.5	36	—	—	—	15.1	8.5	—		156					
-240-M127	2	240	127	30	56	26.3	32	46	275	1.8	13	8.1		155				
-M157	1	—	157	56	—	29.5	42	—	1.7	15.3	8.6		157					
-270-M157	2	270	—	28	58	—	53	—	305	2.2	15.6	8.7		158				
-SLRB8- 75-M 22	1	8	18	5	75	22	26	—	20.3	32	—	24	110	1.1	3.6	0.7		159
- 95-M 42					95	42	—	22.4	—	—	130	—	5.3	1.1		162		
-105-M 22					105	22	56	20.3	—	—	140	1.2	3.8	0.9		160		
-120-M 67					120	67	26	25	—	—	155	—	7.5	1.7		165		
BT40 -125-M 42					125	42	56	22.4	—	—	160	1.3	5.5	1.4		163		
-135-M 22					2	135	22	30	56	20.3	—	46	170	1.6	4.1	1		161
-150-M 67						150	67	56	—	25	—	185	1.4	7.6	2.2		166	
-155-M 42					2	155	42	30	56	22.4	—	46	190	1.7	5.8	1.5		164
-180-M 67					—	180	67	—	25	—	215	1.8	7.9	2.2		167		
-SLFB8- 75-M 22	1	8	18	5	75	22	26	—	20.3	32	—	24	110	1.1	3.6	0.7		168
 - 95-M 42					95	42	—	22.4	—	—	130	—	5.3	1.1		171		
-105-M 22					105	22	56	20.3	—	—	140	1.2	3.8	0.9		169		
-120-M 67					120	67	26	25	—	—	155	—	7.5	1.7		174		
-125-M 42					125	42	56	22.4	—	—	160	1.3	5.5	1.4		172		
-135-M 22					2	135	22	30	56	20.3	—	46	170	1.6	4.1	1		170
-150-M 67					1	150	67	56	—	25	—	185	1.4	7.6	2.2		175	
-155-M 42					2	155	42	30	56	22.4	—	46	190	1.7	5.8	1.5		173
-180-M 67						180	67	28	58	25	36	50	215	1.9	7.9	2		176
-SLSA8- 90 CV	3	8	11	1.5	90	63	—	—	53	—	—	24	125	1.2	3.3	1.4		177
-120 CV					120	93	—	—	—	—	155	1.3	4	2		178		
-150 CV					150	123	—	—	—	—	185	1.5	4.8	2.7		179		
-180 CV					180	153	—	—	—	—	215	1.6	4.9	5		180		
-210 CV					210	183	—	—	—	—	245	1.7	5.8	6.6		181		
-240 CV					240	213	—	—	—	—	275	1.9	6.7	8.3		182		
-SLRA8- 90 CV	3	8	16	4	90	63	—	—	53	—	—	24	125	1.2	3.8	0.7		183
-120 CV					120	93	—	—	—	—	155	1.4	4.2	1.2		184		
-150 CV					150	123	—	—	—	—	185	1.6	4.9	1.8		185		
-180 CV					180	153	—	—	—	—	215	1.7	5.7	2.6		186		
-210 CV					210	183	—	—	—	—	245	1.8	6.5	3.5		187		
-SLFA8- 90 CV	3	8	16	4	90	63	—	—	53	—	—	24	125	1.2	3.8	0.7		188
 -120 CV					120	93	—	—	—	—	155	1.4	4.2	1.2		189		
-150 CV					150	123	—	—	—	—	185	1.6	4.9	1.8		190		
-180 CV					180	153	—	—	—	—	215	1.7	5.7	2.6		191		
-210 CV					210	183	—	—	—	—	245	1.8	6.5	3.5		192		



CODE	Fig.	φD	φC	t	L	M	L ₁	L ₂	φC ₁	φC ₂	φC ₃	H	h	Kg	N	S	Scale model	Feature	
BT40-SLSA10- 95-M 42	1	10	13	1.5	95	42	26	—	17.4	25	—	30	130	1	5.5	2.6	○	193	Shrink-fit Heater
-120-M 67					120	67			20	32			155	1.1	8.1	4		196	
-125-M 42					125	42	56		17.4	25			160		5.7	3.6		194	
-150-M 67					150	67			20	32			185	1.3	8.2	4.6		197	
-M 97						97	26		23.2					1.2		6		199	
-155-M 42	2				155	42	30	53	17.4	25	39		190	1.4	5.9	3.6		195	
-180-M 67					180	67	28	58	20	36	50		215	1.8	8.5	4.4		198	
-M 97	1					97	56	—	23.2	32	—			1.3		6.9		200	
-210-M 97	2				210		30	56			46		245	1.7				201	
-SLSB10- 95-M 42	1	10	16	3	95	42	26	—	20.4	32	—	30	130	1.1	6.3	1.4	○	202	MONO 3° MONO CURVE
-120-M 67					120	67			23				155	1.2	9.3	2.4		205	
-125-M 42					125	42	56		20.4				160	1.3	6.4	1.8		203	
-150-M 67					150	67			23				185		9.5	3		206	
-M 97						97	26		26.2						13	3.6		208	
-155-M 42	2				155	42	30	56	20.4		46		190	1.6	6.7	1.9		204	
-180-M 67					180	67			23				215	1.7	9.8	3		207	
BT40 -M 97	1					97	56	—	26.2		—			1.4	13.2	4.5		209	
-M127						127	26		29.3	42					17.4			211	
-210-M 97	2				210	97	30	56	26.2	32	46		245	1.8	13.5			210	
-M127	1					127	56	—	29.3	42	—			1.6	17.9	4.9		212	
-M157						157	26		32.5					1.5	21.1	5.6		214	
-240-M127					240	127	86		29.3	50			275	2.1	18.5	5	▲	213	
-M157						157	56		32.5					1.8	21.7	5.8		215	
-270-M157	2				270		28	58		42	53		305	2.3	22.2	6.3		216	
-SLRB10- 75-M 22	1	10	22	6	75	22	26	—	24.3	32	—	30	110	1.1	3.8	0.6	×	217	
- 95-M 42					95	42			26.4				130	1.2	6.3	0.8	○	220	
-105-M 22					105	22	56		24.3				140	1.3	4		×	218	
-120-M 67					120	67	26		29	42			155		9.4	1.1	○	223	
-125-M 42					125	42	56		26.4	32			160		6.5	1.2		221	
-135-M 22	2				135	22	30	56	24.3		46		170	1.7	4.3	0.9	×	219	
-150-M 67	1				150	67	56	—	29	42	—		185	1.5	9.6	1.3	○	224	
-155-M 42	2				155	42	30	56	26.4	32	46		190	1.7	6.8			222	
-180-M 67					180	67	28	58	29	42	53		215	2.1	9.8	1.4		225	
-SLFB10- 75-M 22	1	10	22	6	75	22	26	—	24.3	32	—	30	110	1.1	3.8	0.6	×	226	HYPER version
- 95-M 42					95	42			26.4				130	1.2	6.3	0.8	○	229	
-105-M 22					105	22	56		24.3				140	1.3	4		×	227	
-120-M 67					120	67	26		29	42			155		9.4	1.1	○	232	
-125-M 42					125	42	56		26.4	32			160		6.5	1.2		230	
-135-M 22	2				135	22	30	56	24.3		46		170	1.7	4.3	0.9	×	228	
-150-M 67	1				150	67	56	—	29	42	—		185	1.5	9.6	1.3	○	233	
-155-M 42	2				155	42	28	58	26.4	36	50		190	1.9	6.8	1.1		231	
-180-M 67					180	67			29	42	53		215	2.1	9.8	1.4		234	
-SLSA10- 90 CV	3	10	13	1.5	90	63	—	—	53	—	—	30	125	1.2	3.3	1.8	○	235	STRAIGHT arbor
-120 CV					120	93							155	1.5	4.3	1.3		236	
-150 CV					150	123							185	1.6	4.9	2.2		237	
-180 CV					180	153							215	1.7	5.6	3.4		238	
-210 CV					210	183							245		6	6		239	
-240 CV					240	213							275	2	7.9	5.8	▲	240	
-SLRA10- 90 CV	3	10	19	4.5	90	63	—	—	53	—	—	30	125	1.3	3.8	0.7	×	241	OTHERS
-120 CV					120	93							155	1.4	4.6	0.9	○	242	
-150 CV					150	123							185	1.6	5.4	1.4		243	
-180 CV					180	153							215	1.8	6.3	2		244	
-210 CV					210	183							245		7.2	3.1		245	
-SLFA10- 90 CV	3	10	19	4.5	90	63	—	—	53	—	—	30	125	1.3	3.8	0.7	×	246	PERIPHERALS
-120 CV					120	93							155	1.4	4.6	0.9	○	247	
-150 CV					150	123							185	1.6	5.4	1.4		248	
-180 CV					180	153							215	1.8	6.3	2		249	
-210 CV					210	183							245		7.2	3.1		250	



Scale model

Feature	CODE	Fig.	φD	φC	t	L	M	L ₁	L ₂	φC ₁	φC ₂	φC ₃	H	h	Kg	N	S	Scale model	
Shrink-fit Heater	BT40-SLSA12- 95-M 42	1	12	15	1.5	95	42	26	—	19.4	32	—	30	130	1.1	7.1	1.8	○	251
	-120-M 67					120	67			22				155		10.7	3.3		254
	-125-M 42					125	42	56		19.4				160	1.2	7.3	2.3		252
	-150-M 67					150	67			22	36			185	1.4	10.9	3.6		255
	-M 97						97	26		25.2	32				1.2	15.3	4.9		257
	-155-M 42	2				155	42	30	56	19.4		46		190	1.6	7.5	2.3		253
	-180-M 67					180	67			22				215	1.7	11.2	3.9		256
	-M 97	1					97	56	—	25.2		—			1.4	15.5	5.8		258
	-210-M 97	2				210		30	56			46		245	1.7	15.8			259
	MONO 3° MONO CURVE	-SLSB12- 95-M 42	1	12	19	3.5	95	42	26	—	23.4	32	—	30	130	1.1	8	1.1	○
-120-M 67						120	67			26				155	1.2	12.2	1.8		263
-125-M 42						125	42	56		23.4				160	1.3	8.2	1.5		261
-150-M 67						150	67			26				185		12.4	2.5		264
-M 97							97	26		29.2	42					17.9	2.4		266
-155-M 42		2				155	42	30	56	23.4	32	46		190	1.7	8.4	1.6		262
-180-M 67						180	67	28	58	26	36	50		215	1.9	12.6	2.2		265
-M 97		1					97	56	—	29.2	50	—			1.7	18.4	2.6		267
BT40 -M127							127	26		32.3	42				1.5	22.9	3.3		269
-210-M 97		2				210	97	28	58	29.2		53		245	2.1	19	2.9		268
-M127		1					127	56	—	32.3	50	—			1.9	23.5	3.5		270
-M157							157	26		35.5	42				1.7	27.9	4.1		272
-240-M127						240	127	86		32.3	50			275	2.2	24	3.8		271
-M157							157	56		35.5	42				1.9	28.5	4.7		273
-270-M157	2				270		28	58			53		305	2.4	29.1	4.8		274	
2PIECE type	-SLRB12- 75-M 22	1	12	26	7	75	22	26	—	28.3	42	—	30	110	1.2	6.9	0.4	×	275
	- 95-M 42					95	42			30.4				130		8.7	0.6		278
	-105-M 22					105	22	56		28.3				140	1.4	7.5	0.5		276
	-120-M 67					120	67	26		33				155		12.9	0.8		281
	-125-M 42					125	42	56		30.4				160	1.5	9.3	0.7		279
	-135-M 22					135	22	86		28.3	50			170	1.8	8.1	0.6		277
	-150-M 67					150	67	56		33	42			185	1.6	13.5	1.1		282
	-155-M 42	2				155	42	28	58	30.4		53		190	2	9.9	0.8		280
	-180-M 67					180	67			33				215	2.1	14.1	1.1		283
	HYPER version	-SLFB12- 75-M 22	1	12	26	7	75	22	26	—	28.3	42	—	30	110	1.2	6.9	0.4	×
- 95-M 42						95	42			30.4				130		8.7	0.6		287
-105-M 22						105	22	56		28.3				140	1.4	7.5	0.5		285
-120-M 67						120	67	26		33				155		12.9	0.8		290
-125-M 42						125	42	56		30.4				160	1.5	9.3	0.7		288
-135-M 22		2				135	22	28	58	28.3		53		170	1.9	8.1	0.6		286
-150-M 67		1				150	67	56	—	33		—		185	1.6	13.5	1.1		291
-155-M 42						155	42	86		30.4	50			190	2	9.9	0.8		289
-180-M 67		2				180	67	28	58	33	42	53		215	2.1	14.1	1.1		292
OTHERS		-SLSA12- 90 CV	3	12	15	1.5	90	63	—	—	53	—	—	30	125	1.3	3.7	1.5	○
	-120 CV					120	93							155	1.5	4.6	1.2		294
	-150 CV					150	123							185		4.9	2.4		295
	-180 CV					180	153							215	1.7	5.7	3.3		296
	-210 CV					210	183							245	1.9	6.6	4.6		297
	-240 CV					240	213							275	2	8	5.5		298
PERIPHERALS	-SLRA12- 90 CV	3	12	22	5	90	63	—	—	53	—	—	30	125	1.3	3.9	0.6	×	299
	-120 CV					120	93							155	1.6	5.1	0.7		300
	-150 CV					150	123							185	1.7	6	1.1	○	301
	-180 CV					180	153							215		6.9	1.9		302
	-210 CV					210	183							245	1.8	7.7	2.8		303
Technical Information	-SLFA12- 90 CV	3	12	22	5	90	63	—	—	53	—	—	30	125	1.3	3.9	0.6	×	304
	-120 CV					120	93							155	1.6	5.1	0.7		305
	-150 CV					150	123							185	1.7	6	1.1	○	306
	-180 CV					180	153							215		6.9	1.9		307
	-210 CV					210	183							245	1.8	7.7	2.8		308

CODE	Fig.	φD	φC	t	L	M	L ₁	L ₂	φC ₁	φC ₂	φC ₃	H	h	 Kg	 N	 S	Scale model
BT40-SLSB16- 95-M 42	1	16	24	4	95	42	26	—	28.4	42	—	32	105	1.2	12.4	0.7	309
-120-M 67					120	67			31				130	1.3	19.3	1.1	312
-125-M 42					125	42	56		28.4				135	1.4	13	0.9	310
-150-M 67					150	67			31				160	1.5	19.8	1.4	313
-M 97						97	26		34.2					1.4	27.6	1.7	315
-155-M 42	2				155	42	28	58	28.4		53		165	1.9	13.5	1	311
-180-M 67					180	67			31				190	2	20.4	1.5	314
 -M 97	1					97	56	—	34.2		—			1.7	28.1	2.1	316
-M127						127	26		37.3	53					35.8	2.1	318
-210-M 97					210	97	86		34.2	50			220	2.1	28.7		317
-M127						127	56		37.3					2	36.4	2.5	319
-M157						157	26		40.5	53				1.9	44.1	2.7	321
-240-M127					240	127	86		37.3				250	2.5	37	2.6	320
-M157						157	56		40.5	50				2.2	44.7	3.1	322
-270-M157					270		86			53			280	2.7	45.3	3.5	323
-SLRB16- 75-M 22	1	16	32	8	75	22	26	—	34.3	42	—	32	85	1.2	6.9	0.3	324
- 95-M 42					95	42			36.4				105	1.3	12.5	0.5	327
-105-M 22					105	22	56		34.3				115	1.4	7.5		325
-120-M 67					120	67	26		39				130	1.5	19.4	0.7	330
-125-M 42					125	42	56		36.4				135	1.6	13		328
-135-M 22	2				135	22	28	58	34.3		53		145	2	8.1	0.5	326
-150-M 67	1				150	67	56	—	39		—		160	1.7	20	0.9	331
-155-M 42	2				155	42	28	58	36.4		53		165	2.1	13.6	0.7	329
-180-M 67					180	67			39				190	2.3	20.5	1	332
-SLFB16- 75-M 22	1	16	32	8	75	22	26	—	34.3	42	—	32	85	1.2	6.9	0.3	333
 - 95-M 42					95	42			36.4				105	1.3	12.5	0.5	336
-105-M 22					105	22	56		34.3				115	1.4	7.5		334
-120-M 67					120	67	26		39				130	1.5	19.4	0.7	339
-125-M 42					125	42	56		36.4				135	1.6	13		337
-135-M 22					135	22	86		34.3	50			145	1.9	8.1	0.5	335
-150-M 67					150	67	56		39	42			160	1.7	20	0.9	340
-155-M 42					155	42	86		36.4	50			165	2	13.6	0.7	338
-180-M 67	2				180	67	28	58	39	42	53		190	2.3	20.5	1	341
-SLSB16- 90 CV	3	16	21	2.5	90	63	—	—	53	—	—	32	100	1.3	4.2	0.6	342
-120 CV					120	93							130	1.5	5.5	0.8	343
-150 CV					150	123							160	1.6	6.2	1.5	344
-180 CV					180	153							190	1.9	7.5	1.9	345
-210 CV					210	183							220	2	8.2	3	346
-240 CV					240	213							250	2.2	9.5	3.7	347
BT40-SLSB20- 95-M 42	1	20	29	4.5	95	42	26	—	33.4	42	—	40	105	1.2	14.2	0.6	348
-120-M 67					120	67			36				130	1.3	24.5	0.9	351
-125-M 42					125	42	56		33.4				135	1.5	14.8	0.8	349
-150-M 67					150	67			36				160	1.6	25	1.2	352
-M 97						97	26		39.2	53					36.8		354
-155-M 42	2				155	42	28	58	33.4	42	53		165	2	15.3	0.9	350
-180-M 67	1				180	67	86	—	36	50	—		190		25.6	1.2	353
-M 97						97	56		39.2					1.9	37.4	1.4	355
-M127						127	26		42.3	53				1.8	50	1.6	357
-210-M 97					210	97	86		39.2				220	2.4	38	1.6	356
-M127						127	56		42.3	50				2.1	50.5	1.9	358
-M157						157	26		45.5					2	62.3	2.1	360
-240-M127					240	127	86		42.3				250	2.4	51.1	2.3	359
-M157						157	56		45.5						62.9	2.4	361
-270-M157					270		86			53			280	2.9	63.5	2.7	362

CODE	Fig.	ϕD	ϕC	t	L	M	L ₁	L ₂	ϕC_1	ϕC_2	ϕC_3	H	h	Kg	N	S	Scale model
BT40-SLRB20- 95-M 42	1	20	38	9	95	42	26	—	42.4	53	—	40	105	1.5	14.3	0.4	363
-120-M 67					120	67			45				130	1.7	24.6	0.5	366
-125-M 42					125	42	56		42.4				135	1.9	14.9		364
BT40 -150-M 67					150	67			45	50			160	2	25.2	0.7	367
-155-M 42					155	42	86		42.4	53			165	2.2	15.4	0.6	365
-180-M 67					180	67			45	50			190	2.3	25.7	0.9	368
-SLFB20- 95-M 42	1	20	38	9	95	42	26	—	42.4	53	—	40	105	1.5	14.3	0.4	369
 -120-M 67					120	67			45				130	1.7	24.6	0.5	372
-125-M 42					125	42	56		42.4				135	1.9	14.9		370
-150-M 67					150	67			45	50			160	2	25.2	0.7	373
-155-M 42					155	42	86		42.4				165	2.1	15.4		371
-180-M 67					180	67			45				190	2.3	25.7	0.9	374
-SLSB20- 90 CV	3	20	26	3	90	63	—	—	50.5	—	—	40	100	1.3	4.4	0.5	375
-120 CV					120	93			53				130	1.5	5.8	0.8	376
-150 CV					150	123							160	1.6	6.7	1.3	377
-180 CV					180	153							190	1.9	8	1.8	378
-210 CV					210	183							220	2.1	9.4	2.3	379
-240 CV					240	213							250	2.4	10.7	3	380
BT40-SLRB25- 95-M 42	1	25	45	10	95	42	26	—	49.4	53	—	45	105	1.5	16.4	0.3	381
-125-M 42					125		56						135	1.9	17	0.4	382
-155-M 42					155		86						165	2.3	17.5	0.6	383
-SLFB25- 95-M 42	1	25	45	10	95	42	26	—	49.4	53	—	45	105	1.5	16.4	0.3	384
 -125-M 42					125		56						135	1.9	17	0.4	385
-155-M 42					155		86						165	2.3	17.5	0.6	386
BT40-SLRB32- 95-M 42	1	32	54	11	95	42	26	—	58.4	63	—	50	87	1.8	4.7	0.3	387

■ Cleaning tool for a spindle taper hole, STAR DUST

CODE
CLT-NT40-G3

☎ P.226



■ $\phi 70$ Nozzle (HRB-03S)

Required for shrinking the SLRB32.

CODE
HRB-NZL70

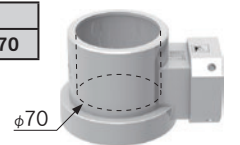

HEAT ROBO Baby 3000S

φ 3

BT40-SLSA3-95-M42

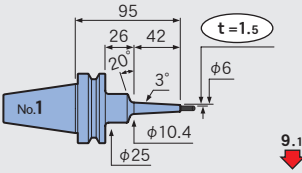

BT40-SLSA3-125-M42

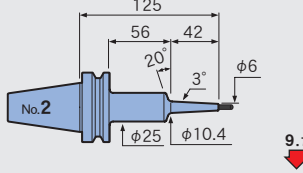

BT40-SLSA3-155-M42

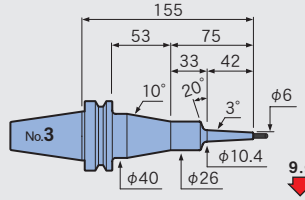

BT40-SLSA3-120-M67

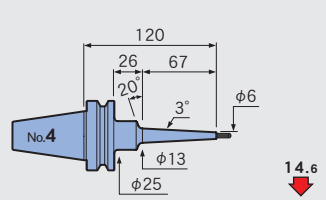

BT40-SLSA3-150-M67

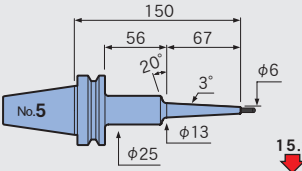

BT40-SLSA3-180-M67

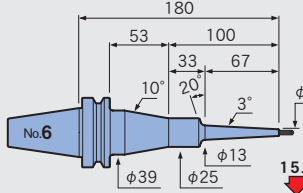

BT40-SLSA3-150-M97

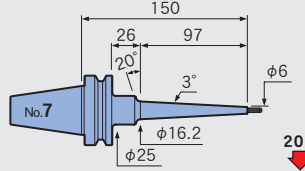

BT40-SLSA3-180-M97

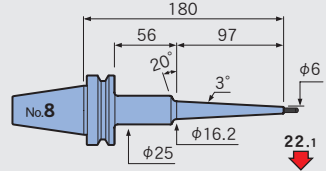

BT40-SLSA3-210-M97

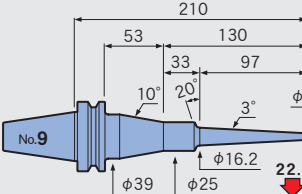

BT40-SLRA3-75-M22

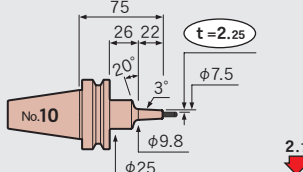

BT40-SLRA3-105-M22

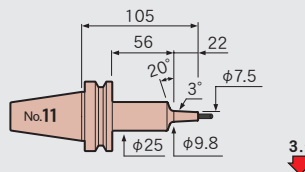

BT40-SLRA3-135-M22

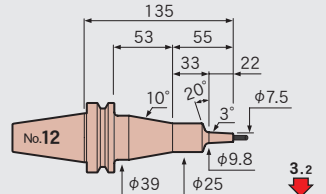

BT40-SLRA3-95-M42

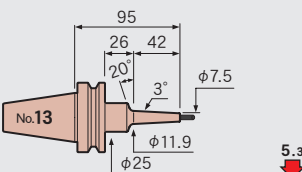

BT40-SLRA3-125-M42

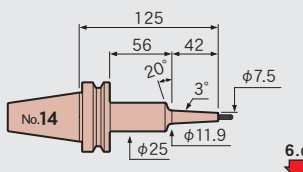

BT40-SLRA3-155-M42

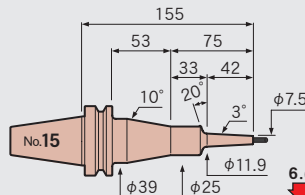

BT40-SLRA3-120-M67

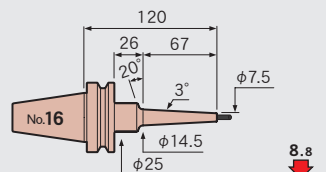

BT40-SLRA3-150-M67

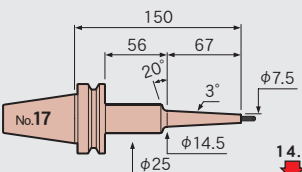

BT40-SLRA3-180-M67

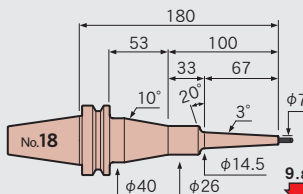

BT40-SLRA3-150-M97

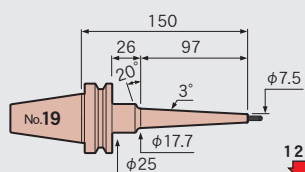

BT40-SLRA3-180-M97

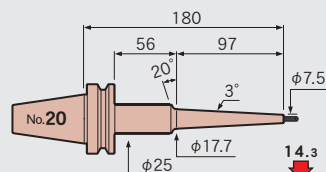

BT40-SLRA3-210-M97

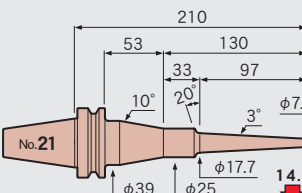

BT40-SLRA3-180-M127

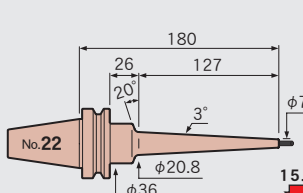

BT40-SLRA3-210-M127

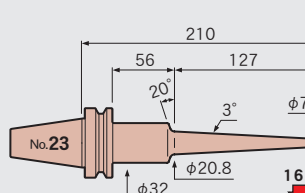

BT40-SLRA3-240-M127

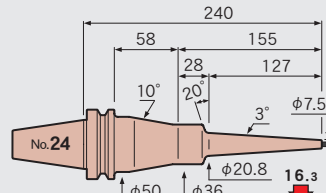

BT40-SLFB3-75-M22

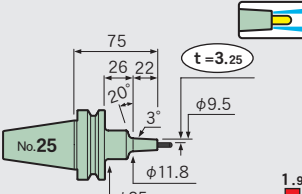

BT40-SLFB3-105-M22

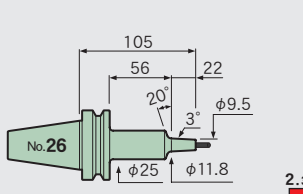

BT40-SLFB3-135-M22

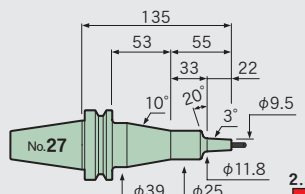

BT40-SLFB3-95-M42

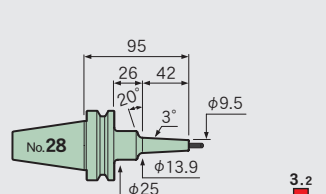

Feature

Shrink-fit Heater

MONO 3°
MONO CURVE

MONO Series

2PIECE type

UNO

HYPER
version

STRAIGHT
arbor

OTHERS

PERIPHERALS

Technical
Information

Feature
Shrink-fit Heater
MONO 3° MONO CURVE
MONO Series
2PIECE type
UNO
HYPER version
STRAIGHT anbor
OTHERS
PERIPHERALS
Technical Information

BT40-SLFB3-125-M42

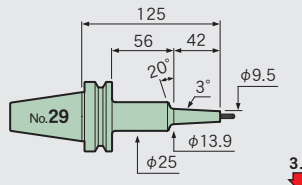

BT40-SLFB3-155-M42

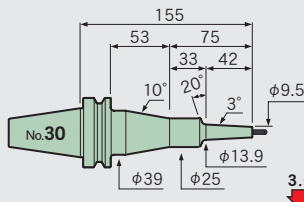

BT40-SLFB3-120-M67

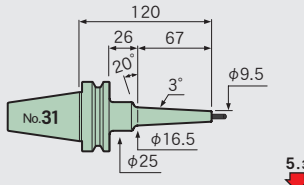

BT40-SLFB3-150-M67

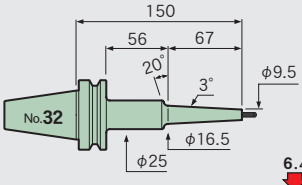

BT40-SLFB3-180-M67

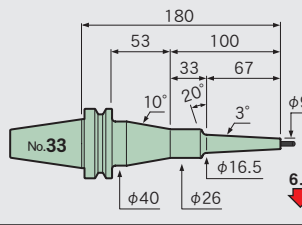

φ 4

BT40-SLSA4-95-M42

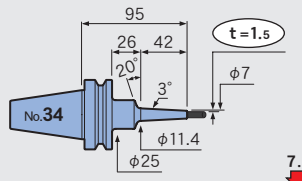

BT40-SLSA4-125-M42

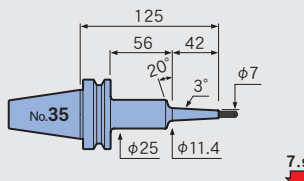

BT40-SLSA4-155-M42

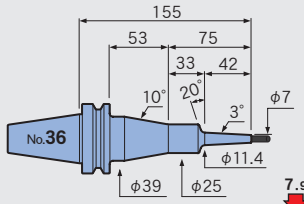

BT40-SLSA4-120-M67

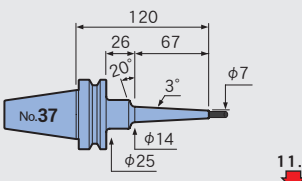

BT40-SLSA4-150-M67

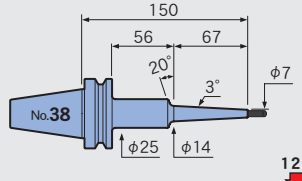

BT40-SLSA4-180-M67

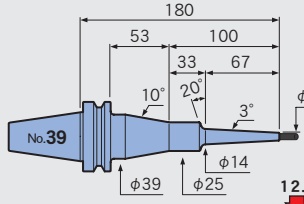

BT40-SLSA4-150-M97

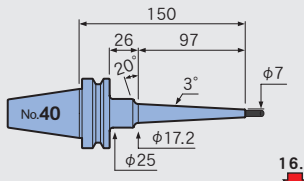

BT40-SLSA4-180-M97

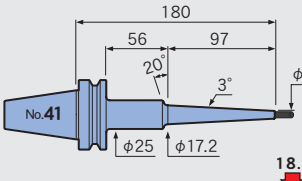

BT40-SLSA4-210-M97

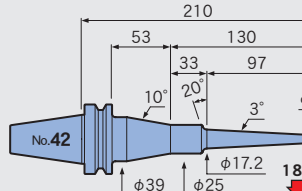

BT40-SLRA4-75-M22

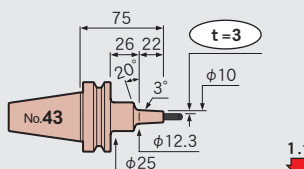

BT40-SLRA4-105-M22

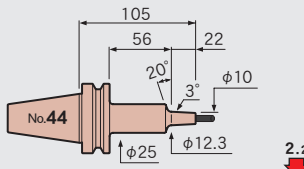

BT40-SLRA4-135-M22

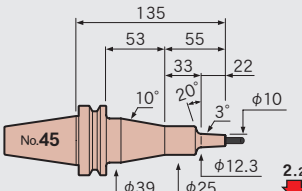

BT40-SLRA4-95-M42

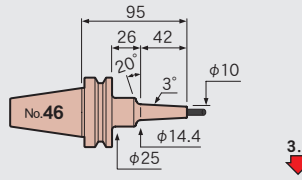

BT40-SLRA4-125-M42

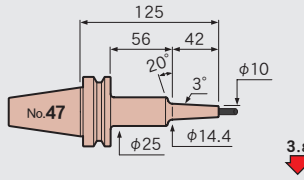

BT40-SLRA4-155-M42

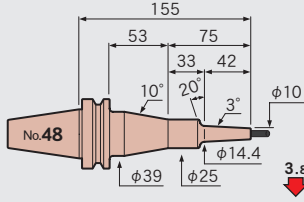

BT40-SLRA4-120-M67

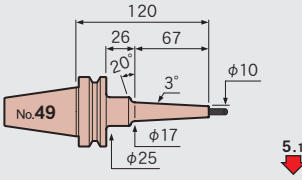

<p>BT40-SLRA4-150-M67</p>	<p>BT40-SLRA4-180-M67</p>	<p>BT40-SLRA4-150-M97</p>	<p>BT40-SLRA4-180-M97</p>
<p>BT40-SLRA4-210-M97</p>	<p>BT40-SLRA4-180-M127</p>	<p>BT40-SLRA4-210-M127</p>	<p>BT40-SLRA4-240-M127</p>
<p>BT40-SLFB4-75-M22</p>	<p>BT40-SLFB4-105-M22</p>	<p>BT40-SLFB4-135-M22</p>	<p>BT40-SLFB4-95-M42</p>
<p>BT40-SLFB4-125-M42</p>	<p>BT40-SLFB4-155-M42</p>	<p>BT40-SLFB4-120-M67</p>	<p>BT40-SLFB4-150-M67</p>
<p>BT40-SLFB4-180-M67</p>	<p>BT40-SLSA4-90 CV</p>	<p>BT40-SLSA4-120 CV</p>	<p>BT40-SLSA4-150 CV</p>
<p>BT40-SLSA4-180 CV</p>	<p>BT40-SLSA4-210 CV</p>	<p>BT40-SLSA4-240 CV</p>	<p>BT40-SLRA4-120 CV</p>
<p>BT40-SLRA4-150 CV</p>	<p>BT40-SLRA4-180 CV</p>	<p>BT40-SLRA4-210 CV</p>	

Feature

Shrink-fit Heater

MONO 3°
MONO CURVE

MONO Series

2PIECE type

UNO

HYPER
version

STRAIGHT
arbor

OTHERS

PERIPHERALS

Technical
information

φ 6

Feature

Shrink-fit Heater

MONO 3° MONO CURVE

MONO Series

2PIECE type

UNO

HYPER version

STRAIGHT anbor

OTHERS

PERIPHERALS

Technical Information

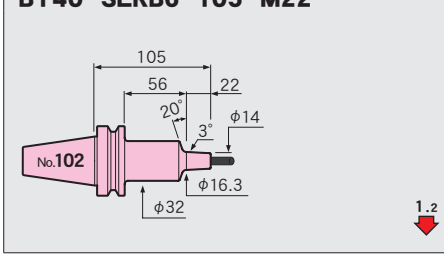
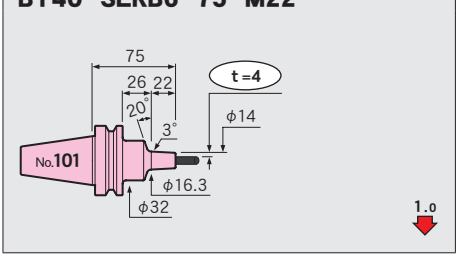
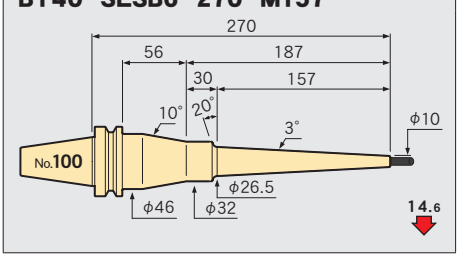
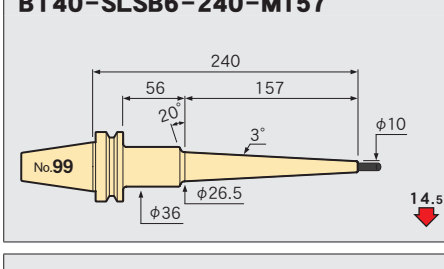
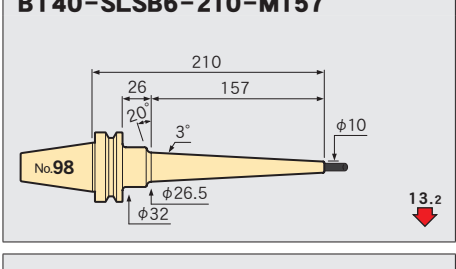
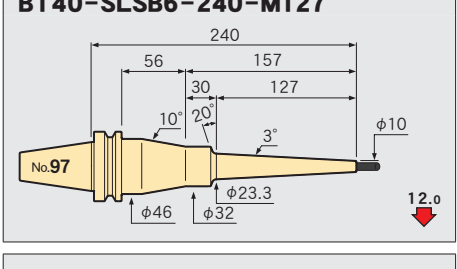
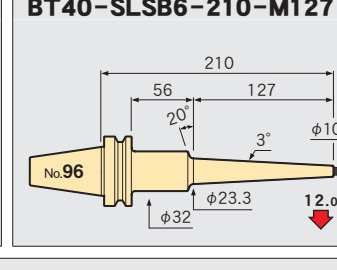
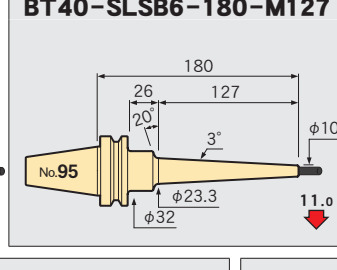
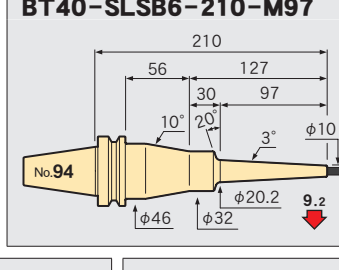
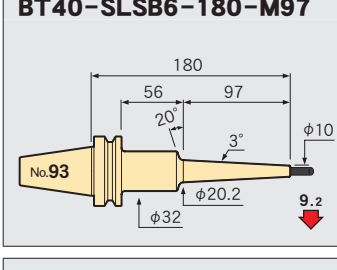
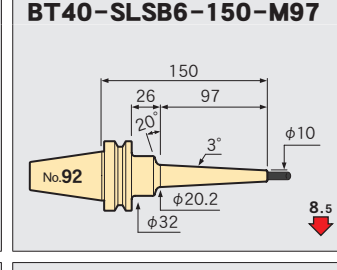
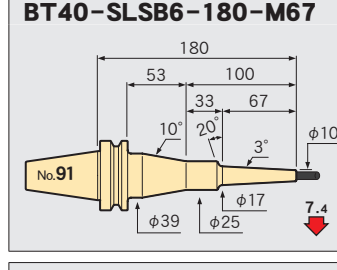
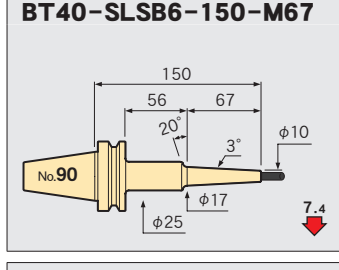
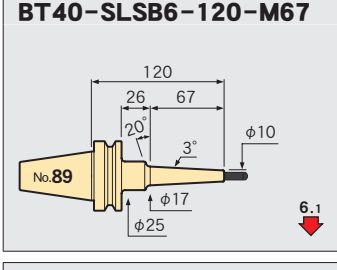
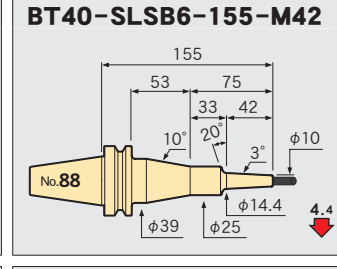
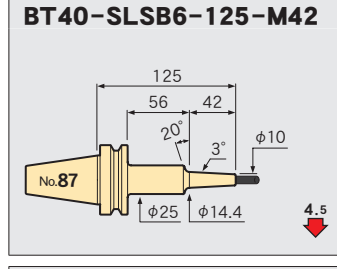
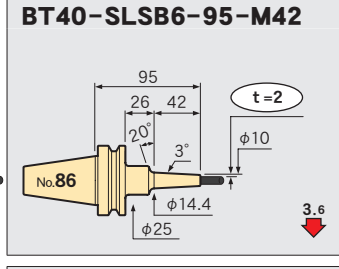
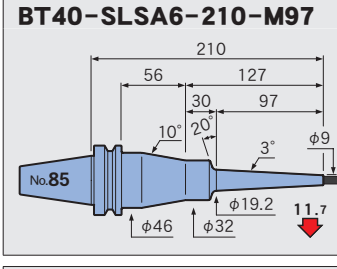
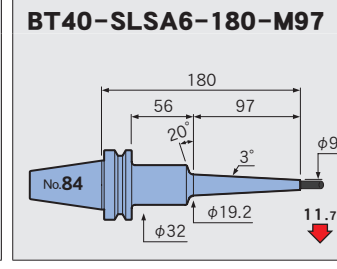
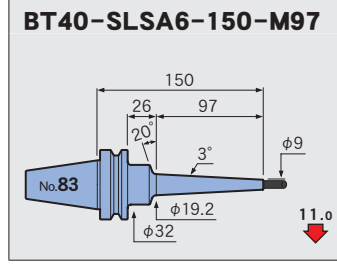
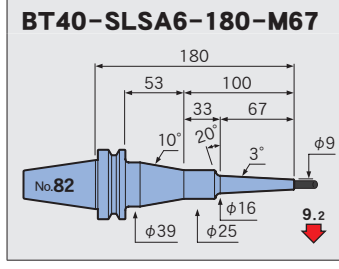
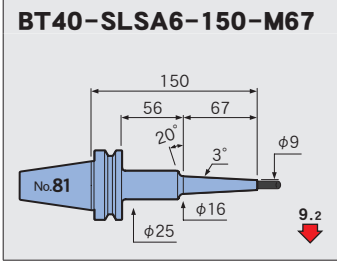
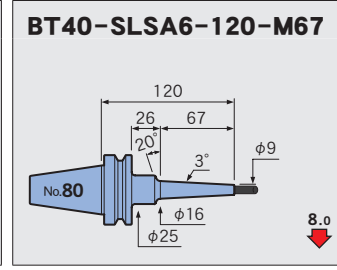
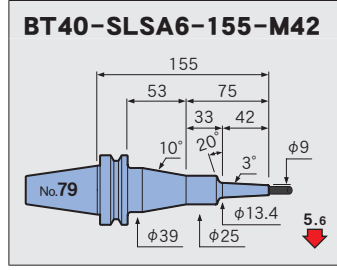
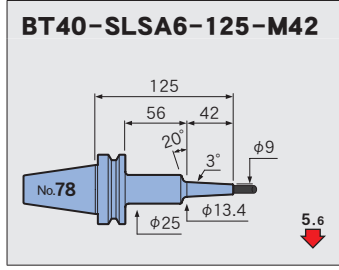
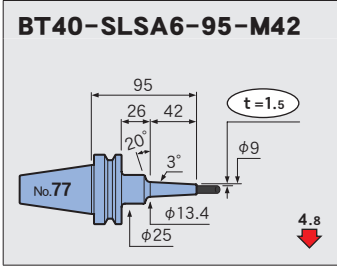

<p>BT40-SLRB6-135-M22</p>	<p>BT40-SLRB6-95-M42</p>	<p>BT40-SLRB6-125-M42</p>	<p>BT40-SLRB6-155-M42</p>
<p>BT40-SLRB6-120-M67</p>	<p>BT40-SLRB6-150-M67</p>	<p>BT40-SLRB6-180-M67</p>	<p>BT40-SLFB6-75-M22</p>
<p>BT40-SLFB6-105-M22</p>	<p>BT40-SLFB6-135-M22</p>	<p>BT40-SLFB6-95-M42</p>	<p>BT40-SLFB6-125-M42</p>
<p>BT40-SLFB6-155-M42</p>	<p>BT40-SLFB6-120-M67</p>	<p>BT40-SLFB6-150-M67</p>	<p>BT40-SLFB6-180-M67</p>
<p>BT40-SLSA6-90 CV</p>	<p>BT40-SLSA6-120 CV</p>	<p>BT40-SLSA6-150 CV</p>	<p>BT40-SLSA6-180 CV</p>
<p>BT40-SLSA6-210 CV</p>	<p>BT40-SLSA6-240 CV</p>	<p>BT40-SLRA6-90 CV</p>	<p>BT40-SLRA6-120 CV</p>
<p>BT40-SLRA6-150 CV</p>	<p>BT40-SLRA6-180 CV</p>	<p>BT40-SLRA6-210 CV</p>	<p>BT40-SLFA6-90 CV</p>

Feature

Shrink-fit Heater

MONO Series

2PIECE type

UNO

HYPER version

STRAIGHT arbor

OTHERS

PERIPHERALS

Technical Information

BT40-SLFA6-120 CV

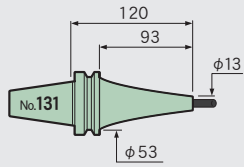

BT40-SLFA6-150 CV

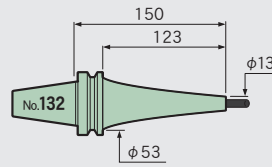

BT40-SLFA6-180 CV

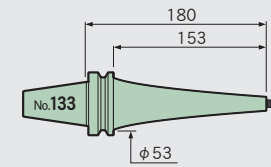

BT40-SLFA6-210 CV

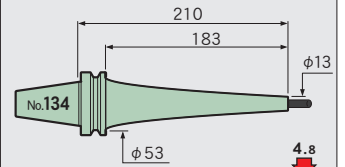

φ 8

BT40-SLSA8-95-M42

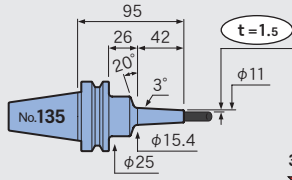

BT40-SLSA8-125-M42

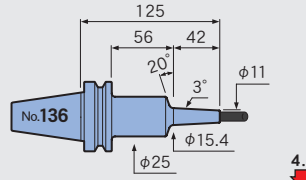

BT40-SLSA8-155-M42

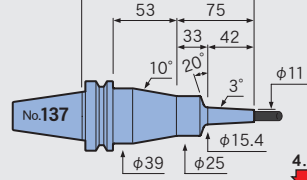

BT40-SLSA8-120-M67

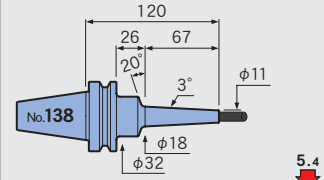

BT40-SLSA8-150-M67

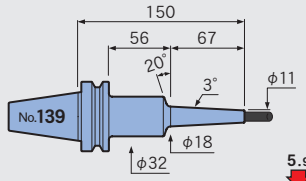

BT40-SLSA8-180-M67

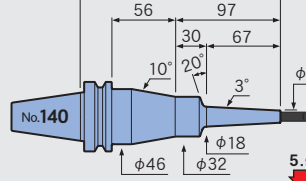

BT40-SLSA8-150-M97

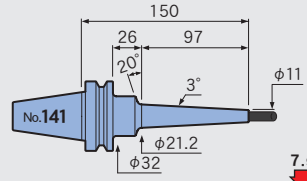

BT40-SLSA8-180-M97

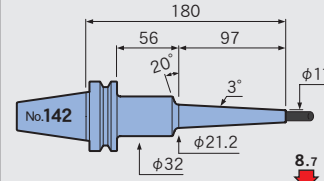

BT40-SLSA8-210-M97

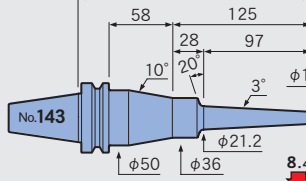

BT40-SLSB8-95-M42

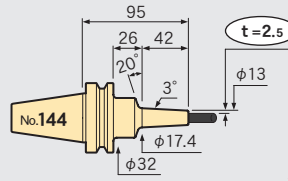

BT40-SLSB8-125-M42

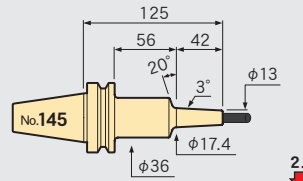

BT40-SLSB8-155-M42

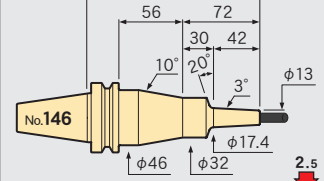

BT40-SLSB8-120-M67

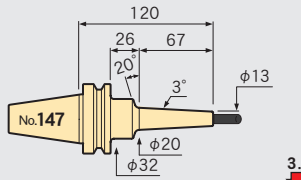

BT40-SLSB8-150-M67

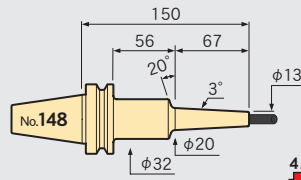

BT40-SLSB8-180-M67

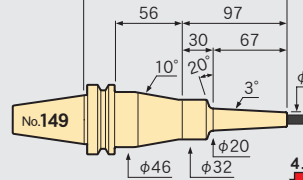

BT40-SLSB8-150-M97

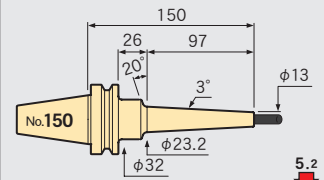

BT40-SLSB8-180-M97

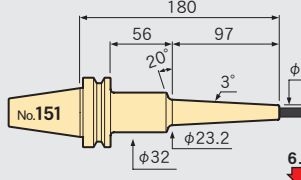

BT40-SLSB8-210-M97

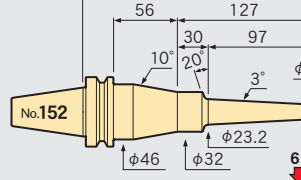

BT40-SLSB8-180-M127

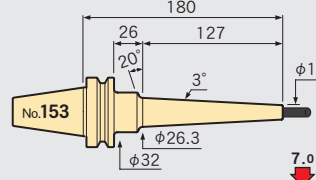

BT40-SLSB8-210-M127

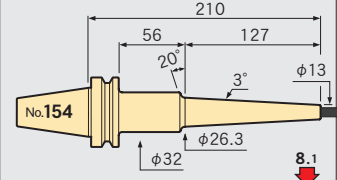

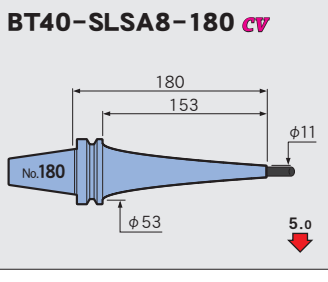
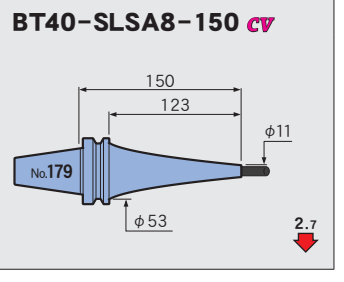
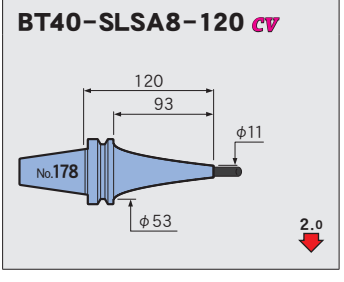
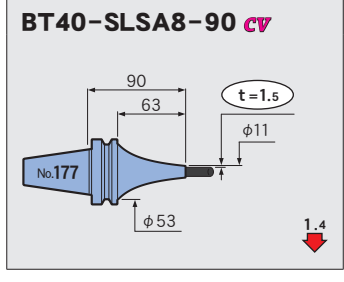
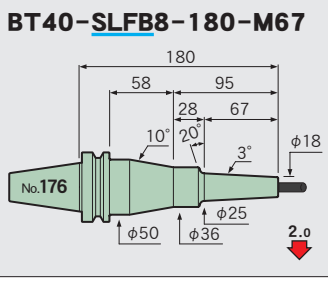
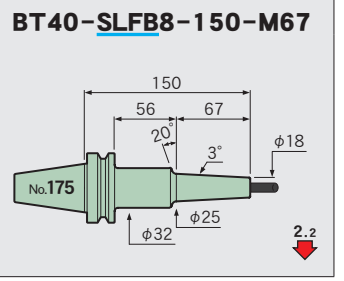
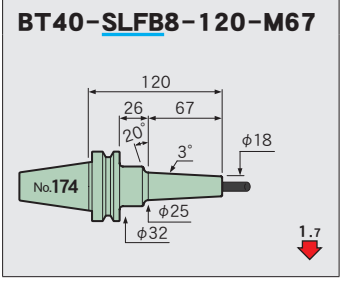
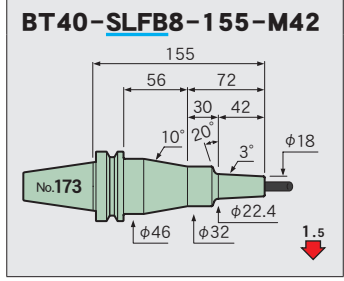
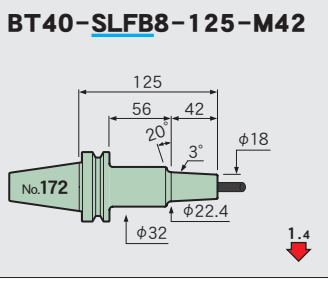
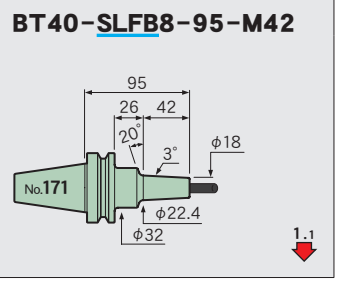
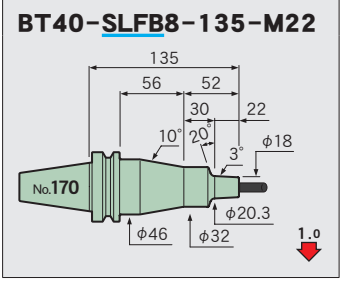
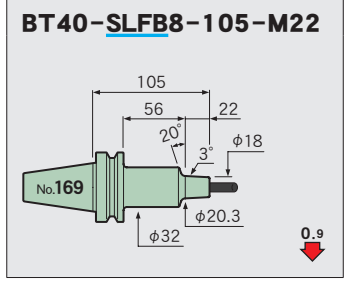
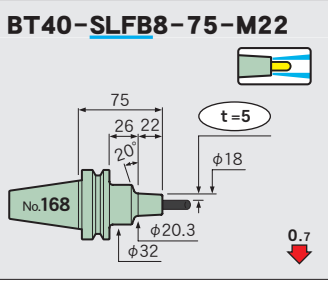
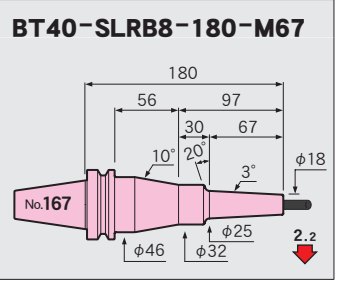
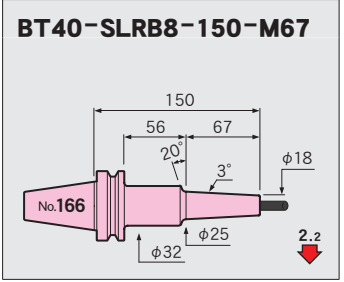
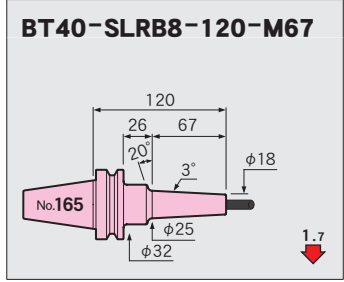
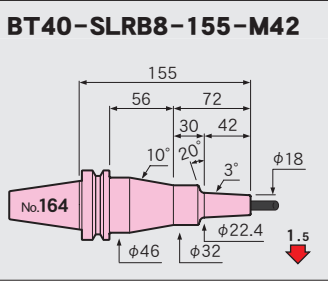
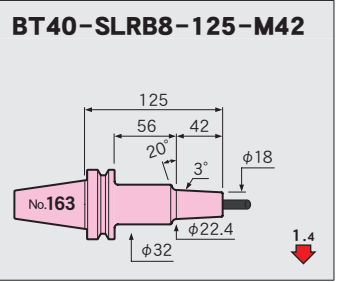
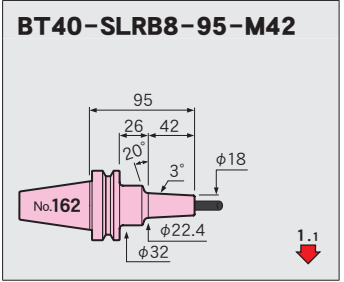
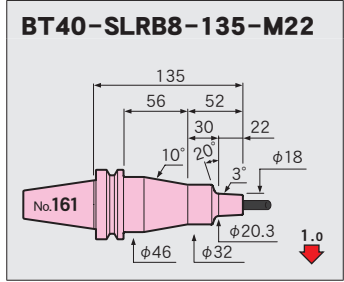
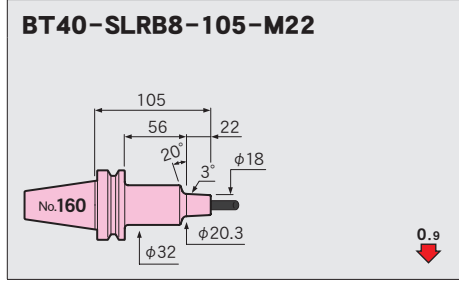
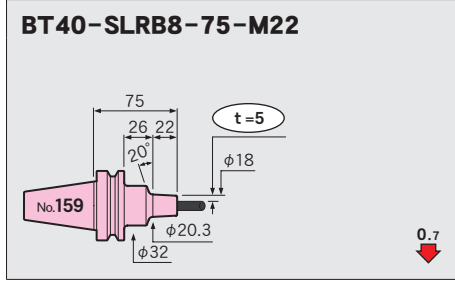
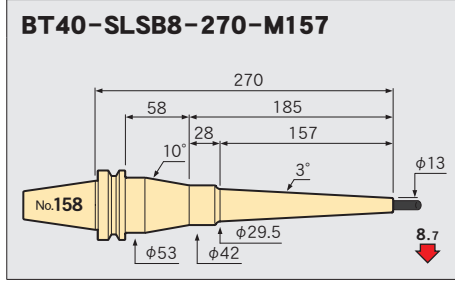
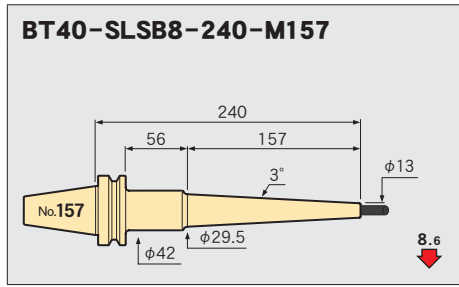
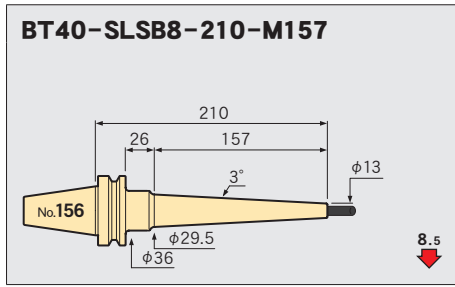
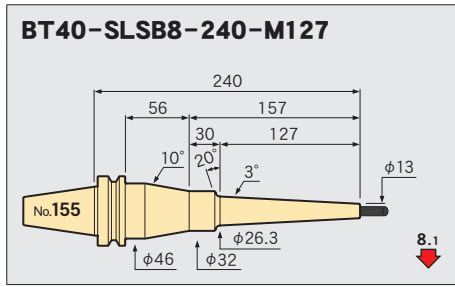

Feature
Shrink-fit Heater
MONO 3°
MONO CURVE
MONO Series
2PIECE type
UNO
HYPER version
STRAIGHT arbor
OTHERS
PERIPHERALS
Technical Information

Feature
Shrink-fit Heater
MONO 3° MONO CURVE
MONO Series
2PIECE type
UNO
HYPER version
STRAIGHT anbor
OTHERS
PERIPHERALS
Technical Information

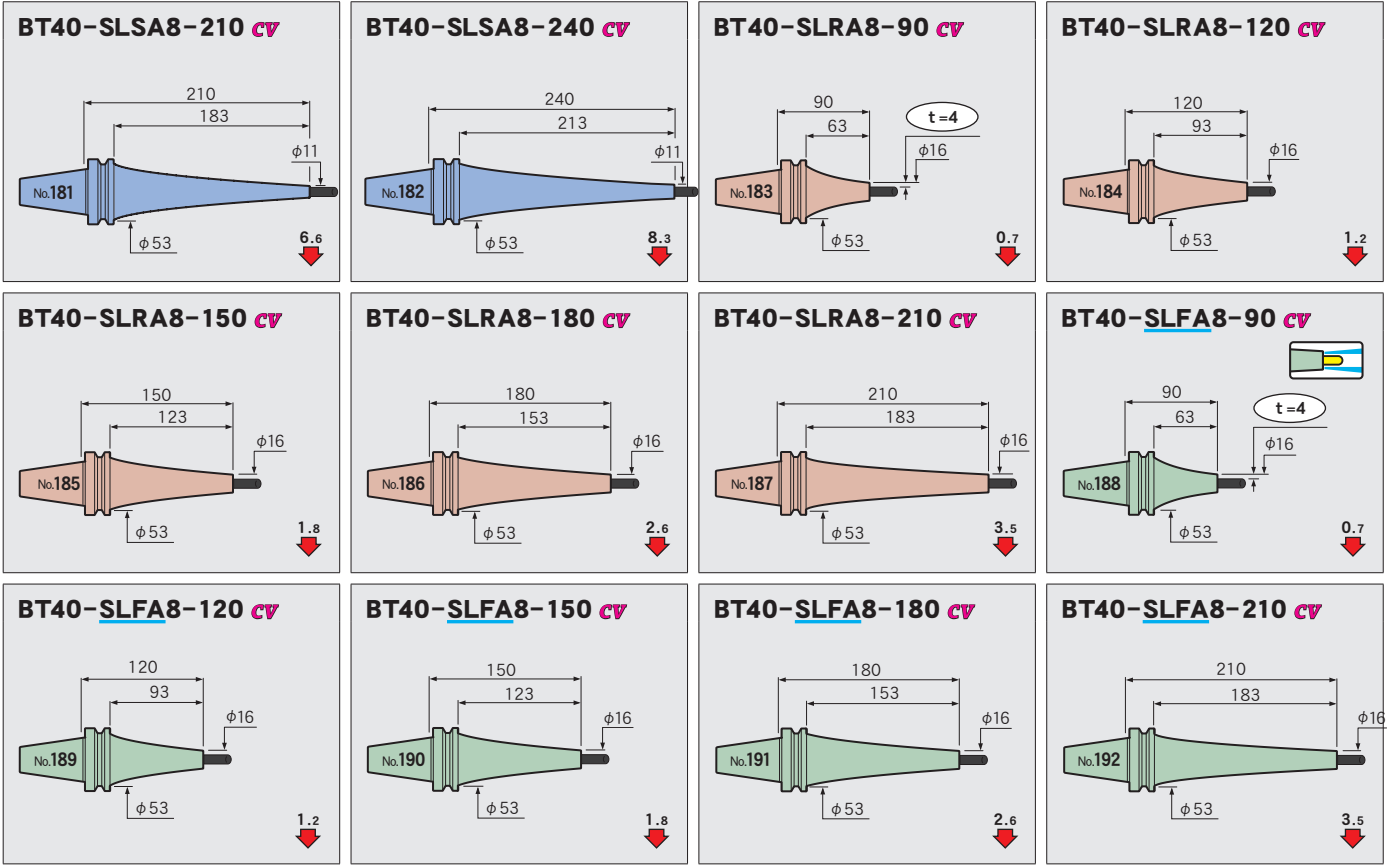

$\phi 10$

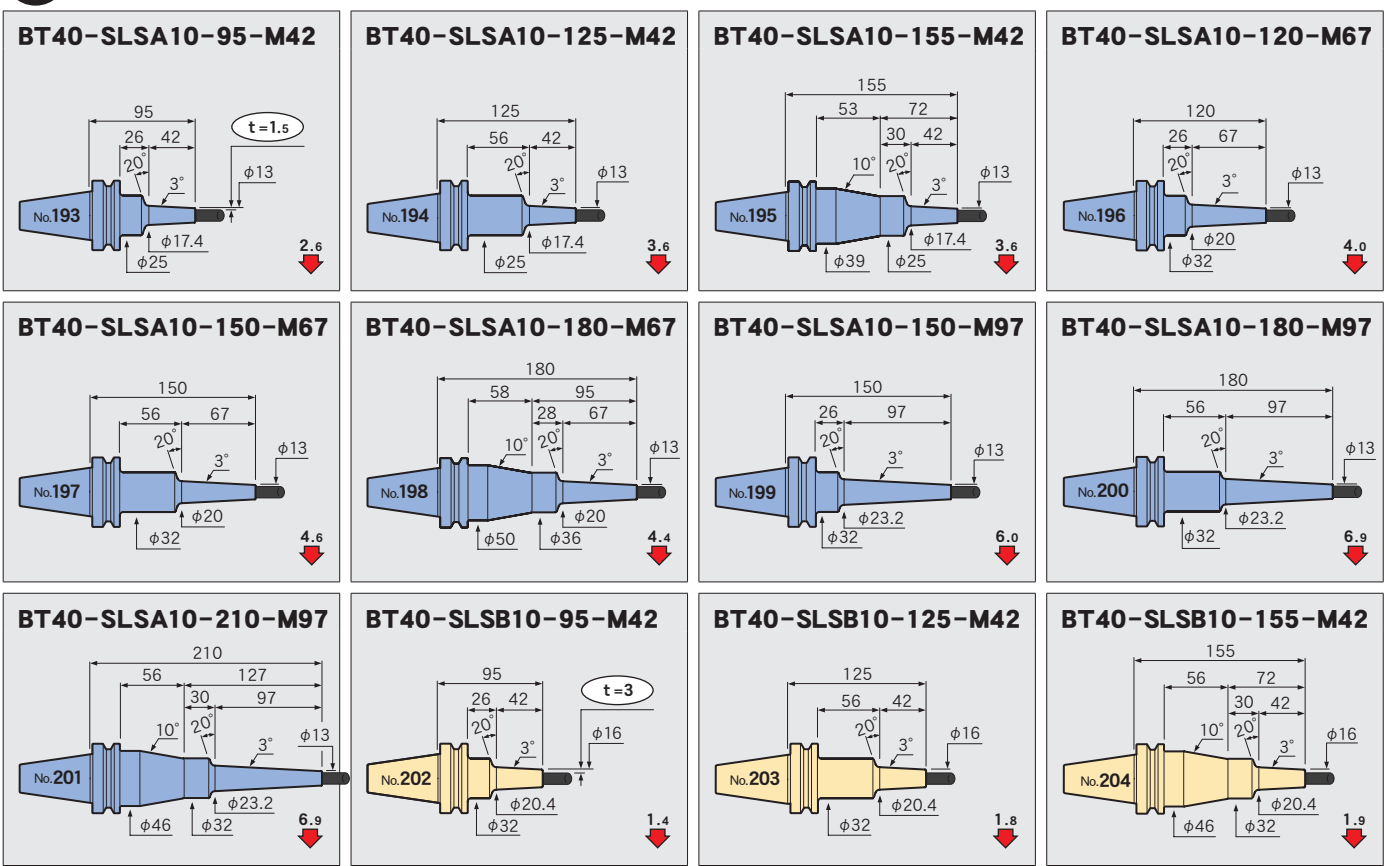

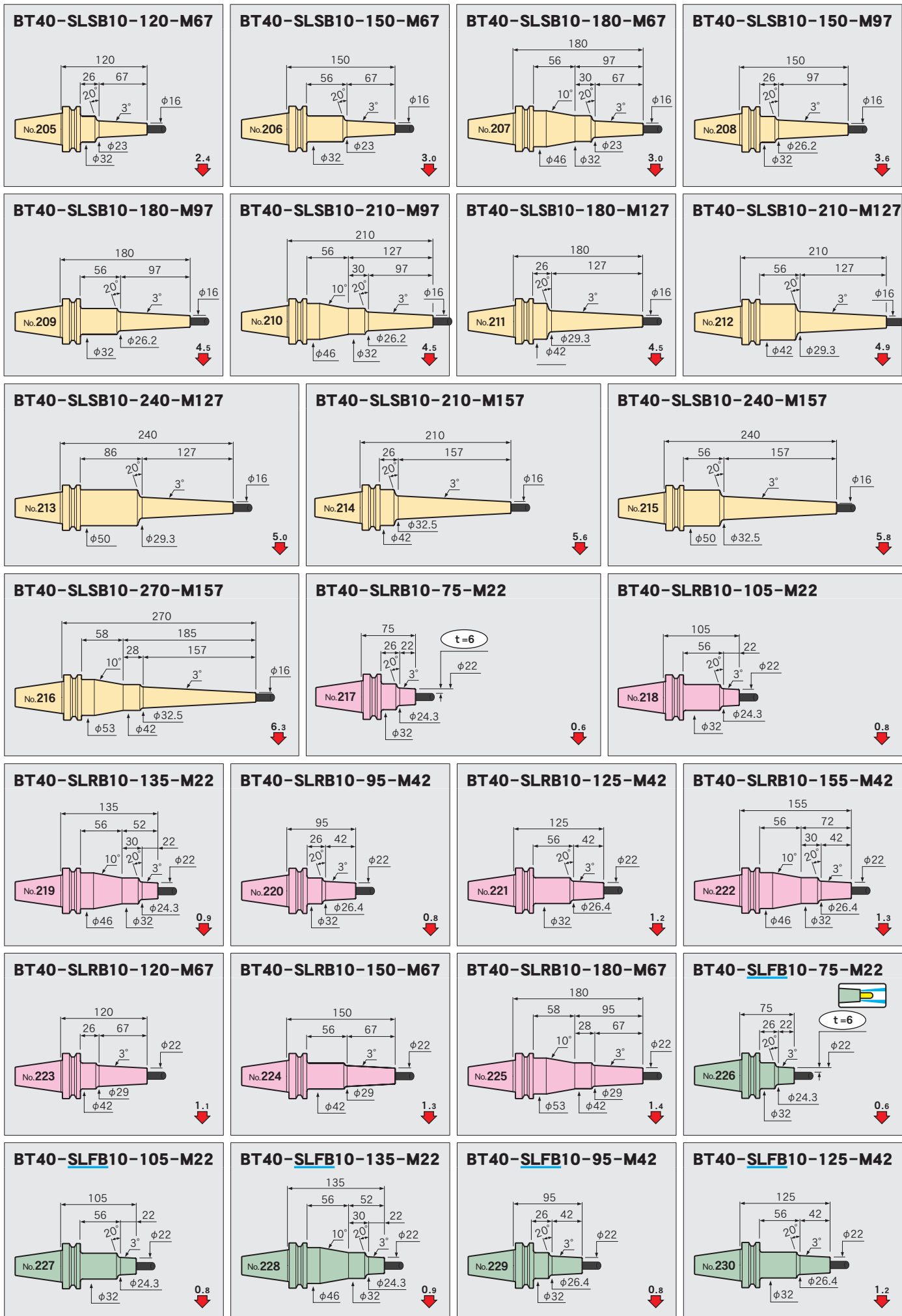

Feature
Shrink-fit Heater
MONO 3° MONO CURVE
MONO Series
2PIECE type
UNO
HYPER version
STRAIGHT arbor
OTHERS
PERIPHERALS
Technical Information

Feature
Shrink-fit Heater
MONO 3° MONO CURVE
MONO Series
2PIECE type
UNO
HYPER version
STRAIGHT arbor
OTHERS
PERIPHERALS
Technical Information

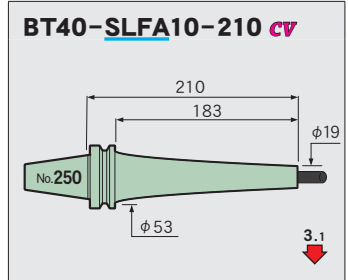
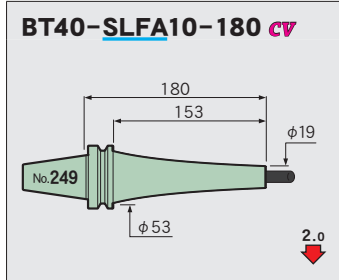
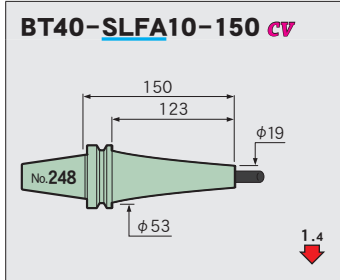
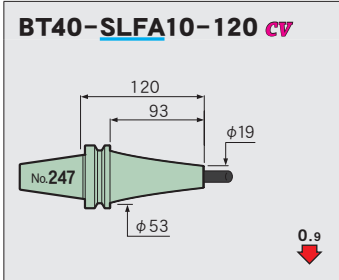
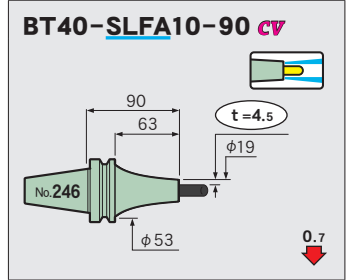
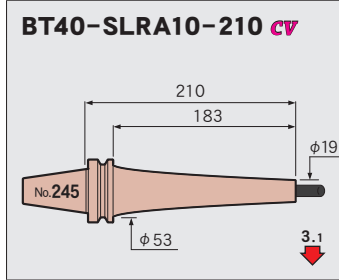
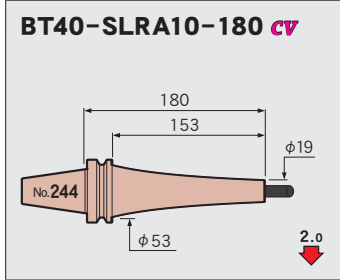
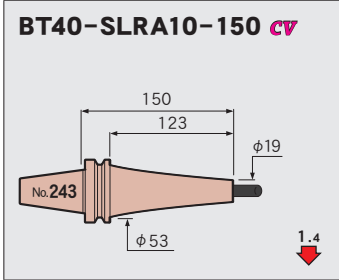
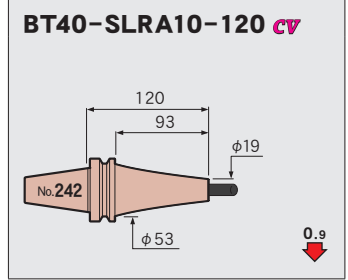
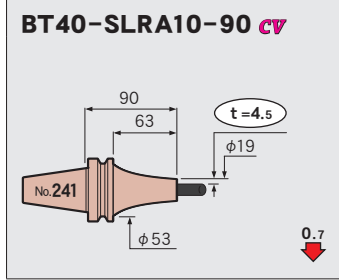
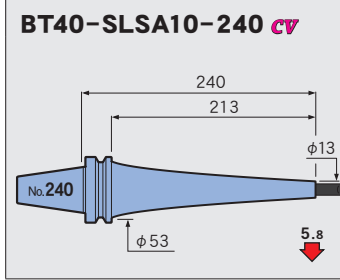
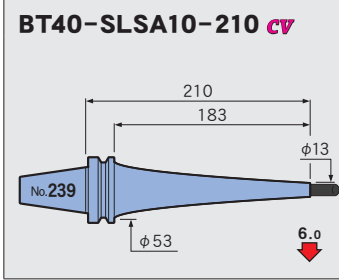
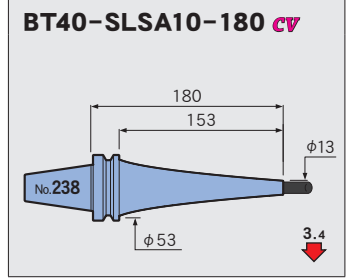
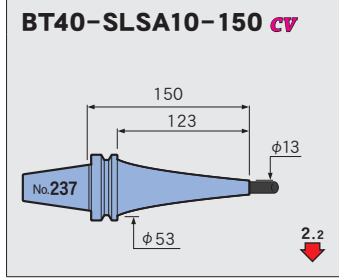
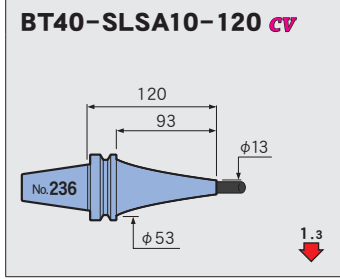
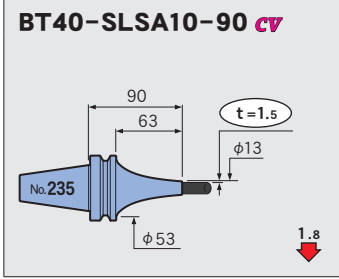
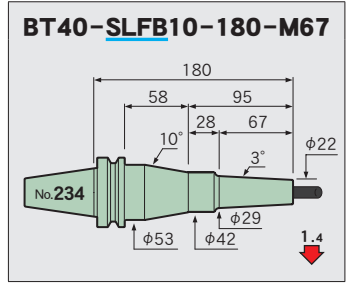
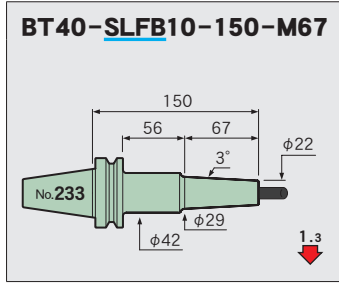
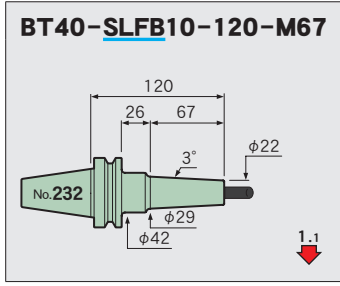
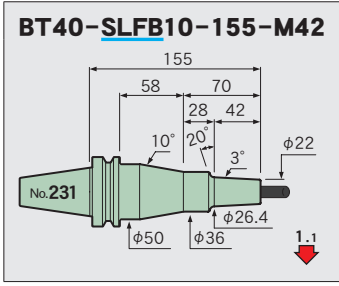

φ12

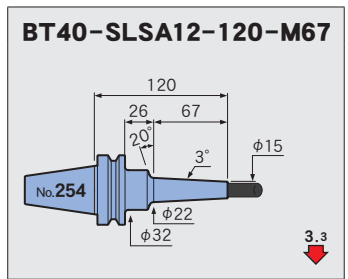
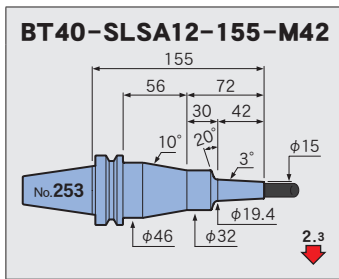
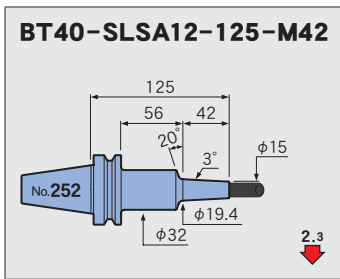
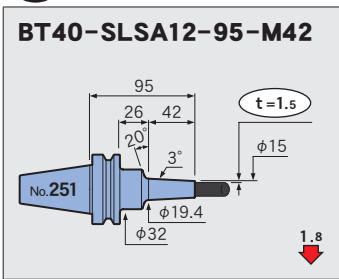

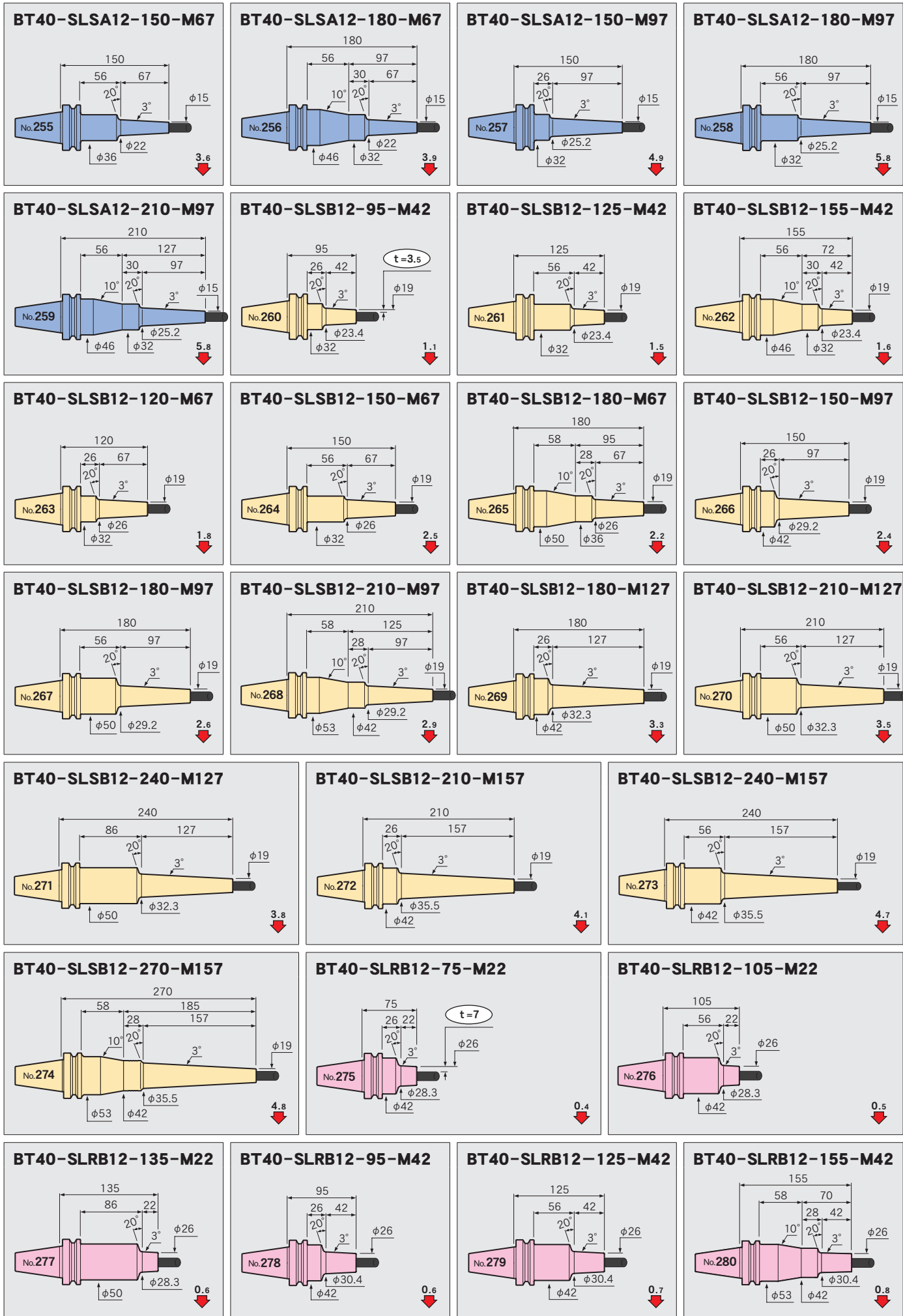

Feature

Shrink-fit Heater

MONO 3°
MONO CURVE

MONO Series

2PIECE type

UNO

HYPER
version

STRAIGHT
arbor

OTHERS

PERIPHERALS

Technical
Information

Feature
Shrink-fit Heater
MONO 3° MONO CURVE
MONO Series
2PIECE type
UNO
HYPER version
STRAIGHT anbor
OTHERS
PERIPHERALS
Technical Information

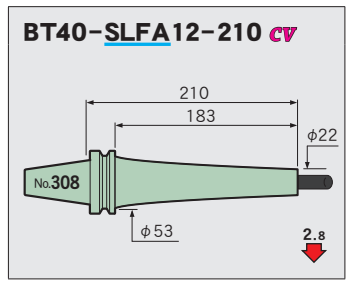
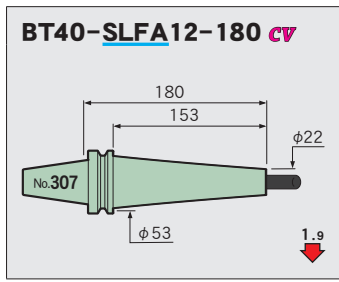
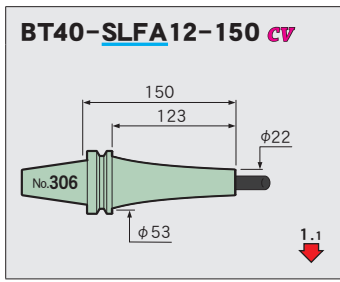
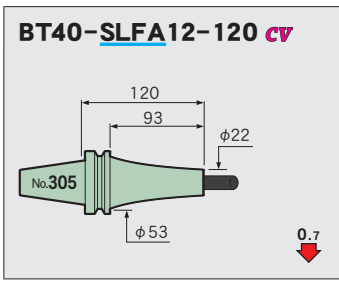
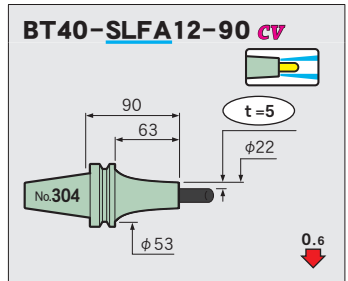
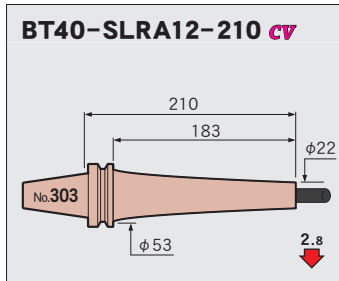
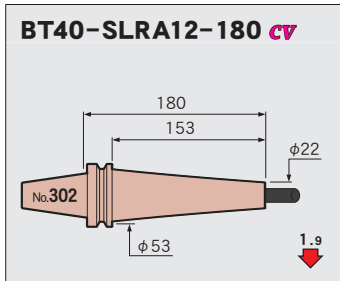
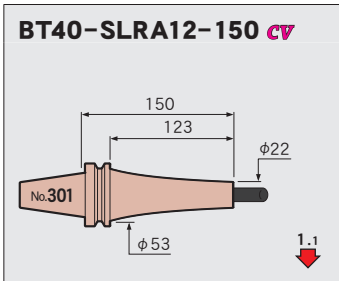
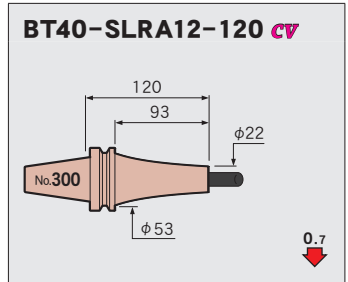
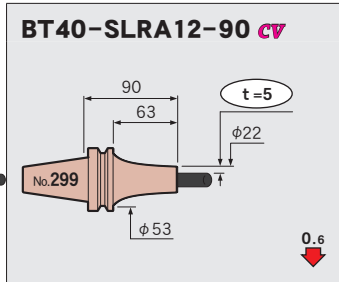
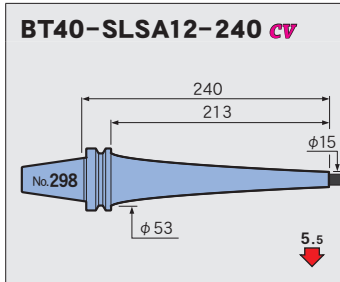
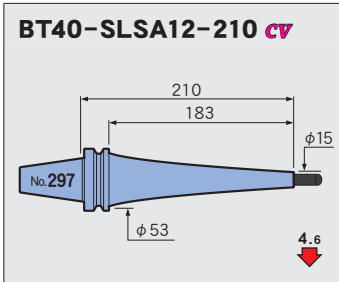
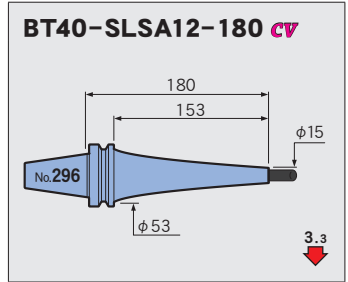
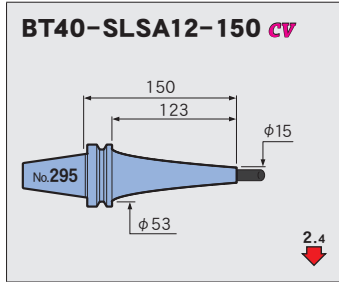
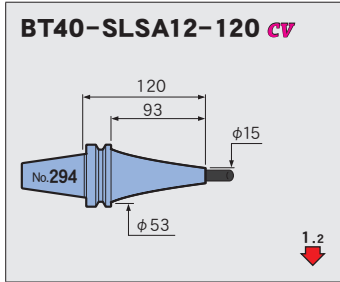
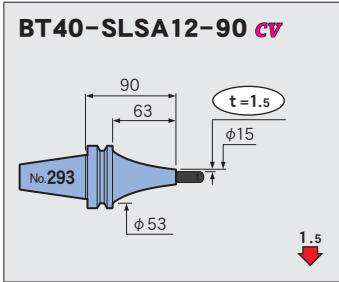
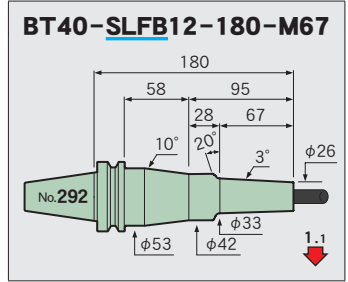
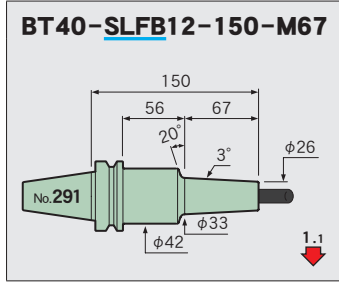
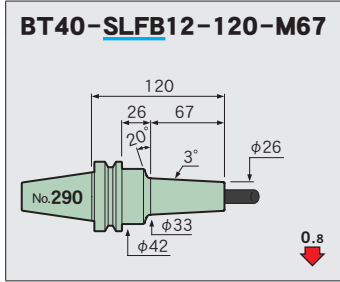
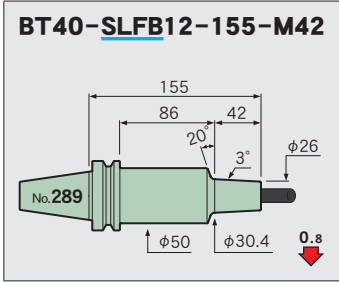
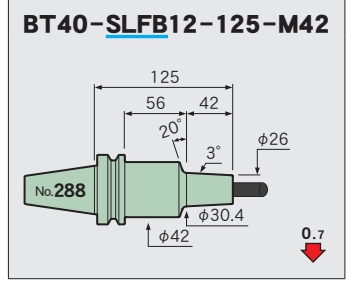
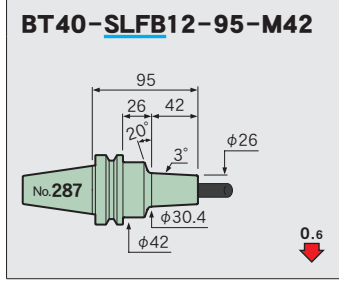
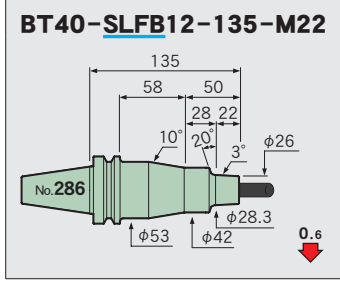
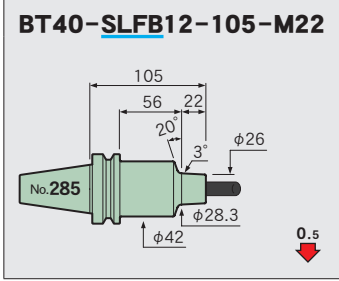
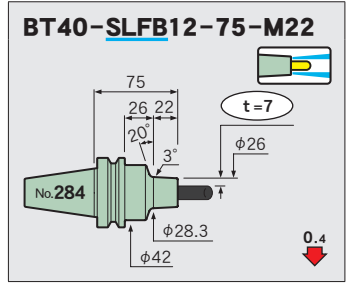
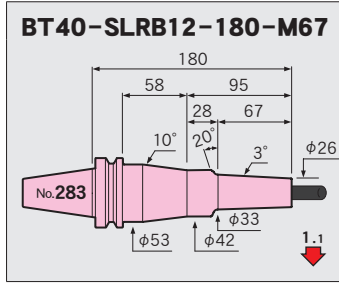
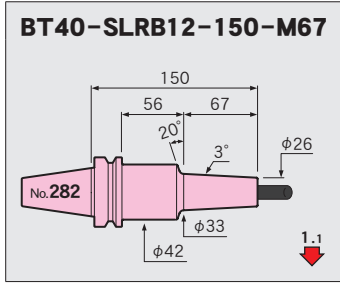
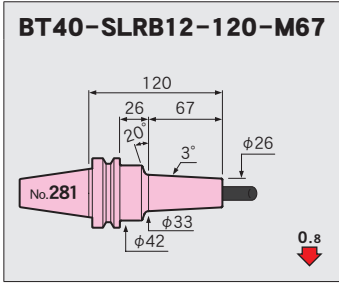

φ16

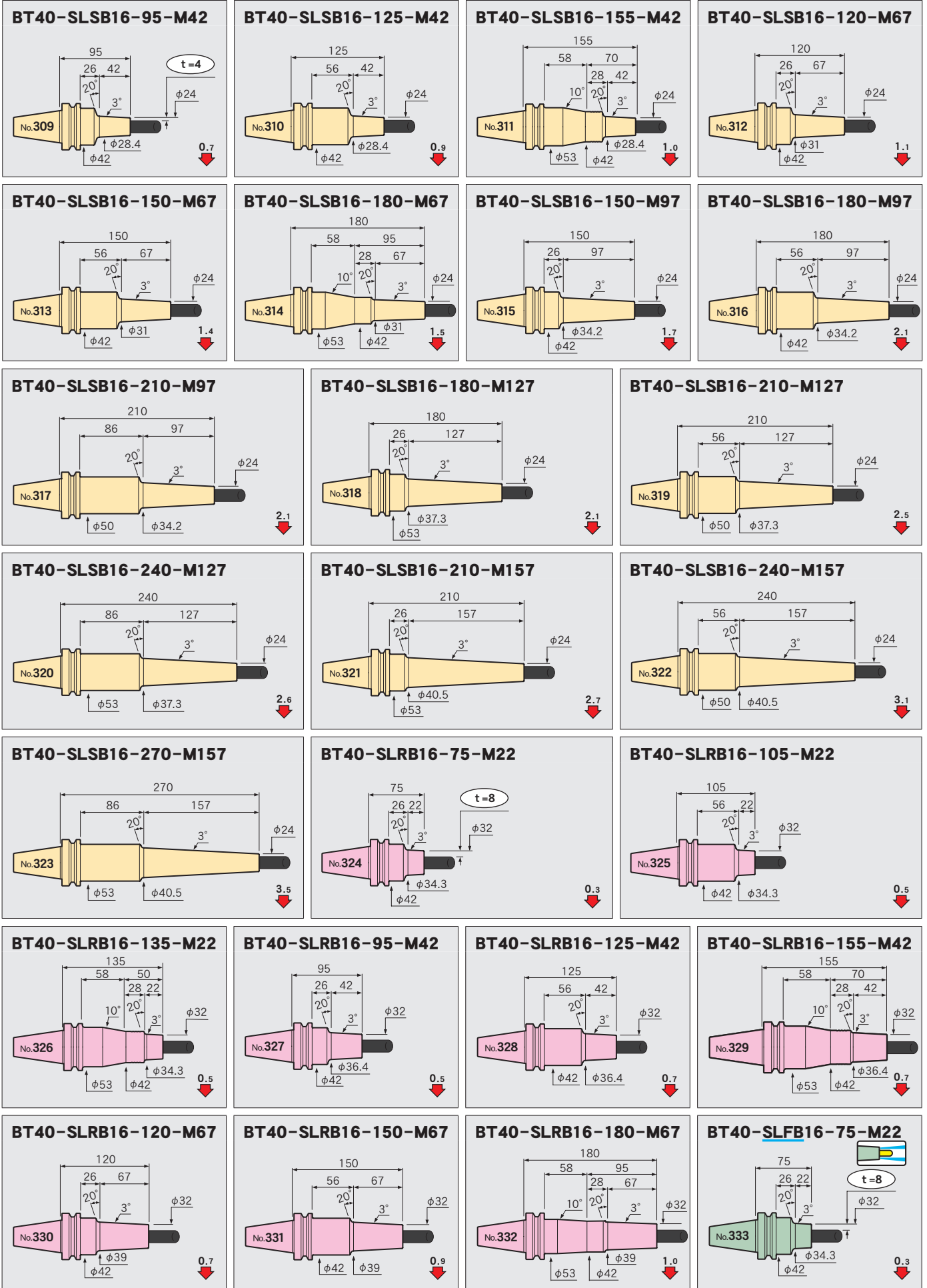

Feature

Shrink-fit Heater

MONO 3°
MONO CURVE

MONO Series

2PIECE type

UNO

HYPER
version

STRAIGHT
arbor

OTHERS

PERIPHERALS

Technical
Information

Feature
Shrink-fit Heater
MONO 3° MONO CURVE
MONO Series
2PIECE type
UNO
HYPER version
STRAIGHT arbor
OTHERS
PERIPHERALS
Technical Information

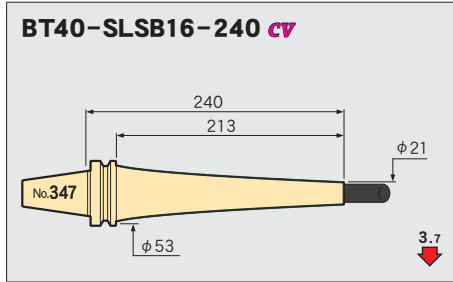
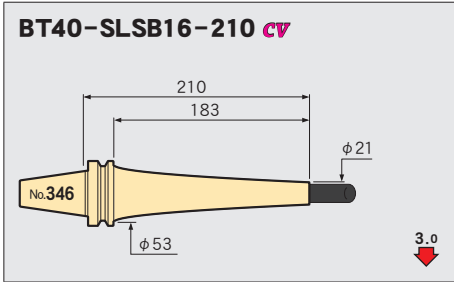
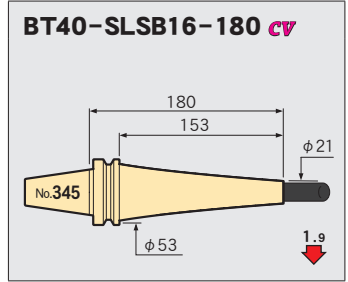
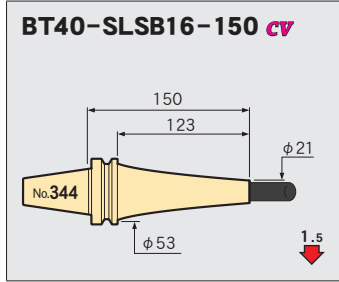
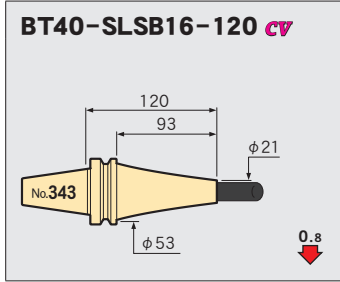
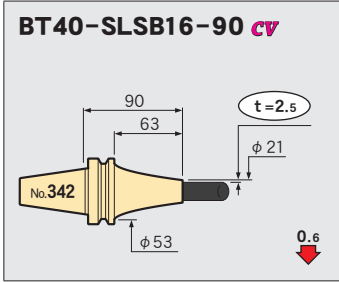
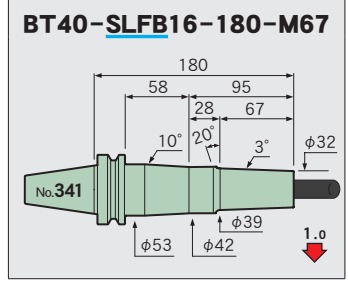
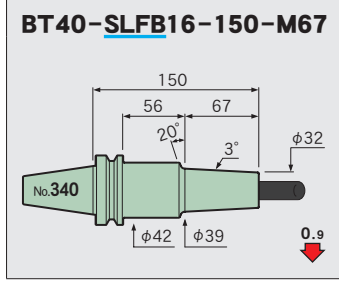
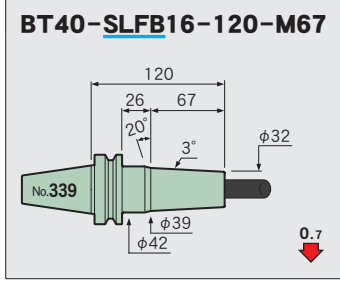
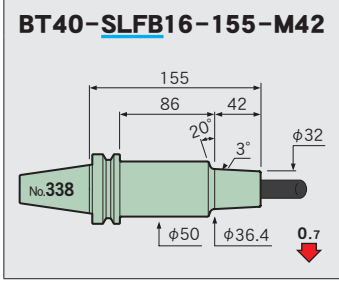
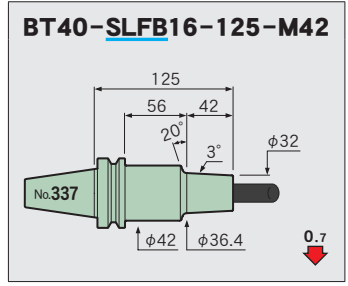
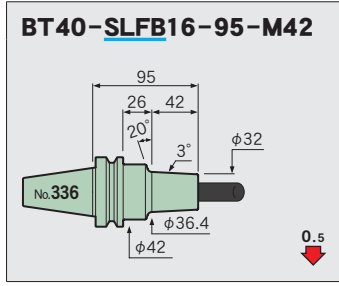
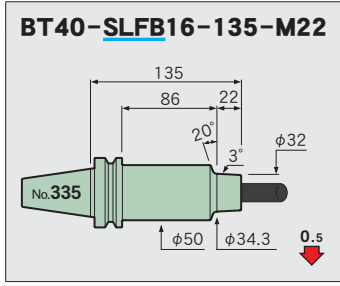
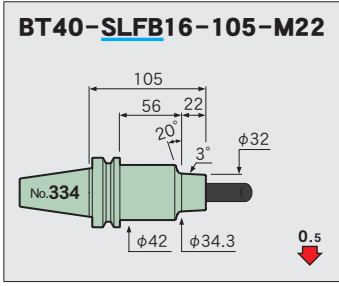

φ20

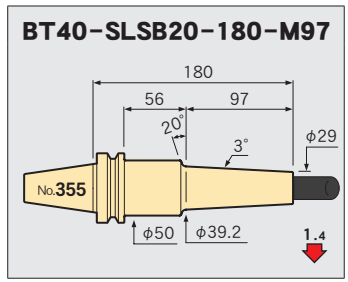
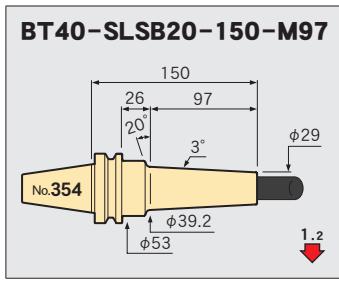
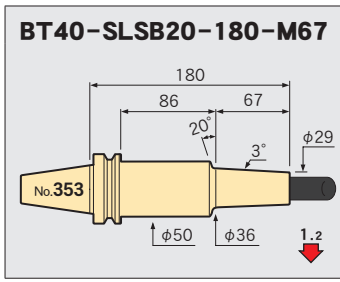
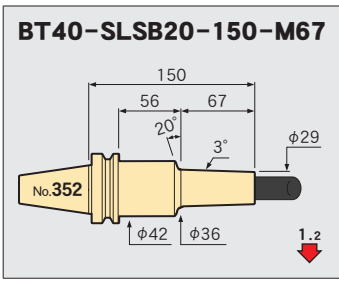
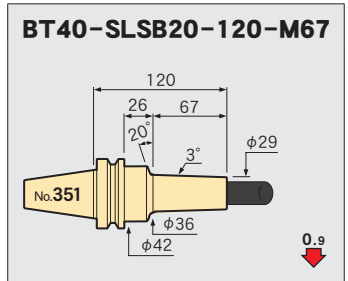
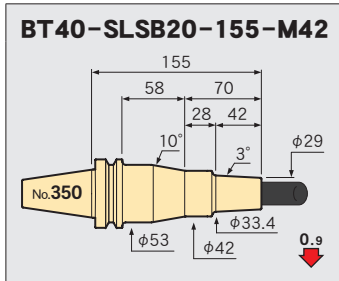
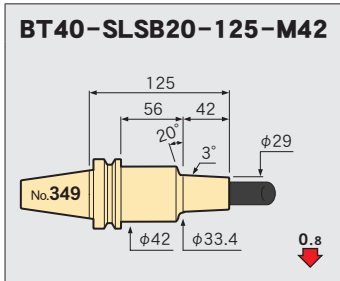
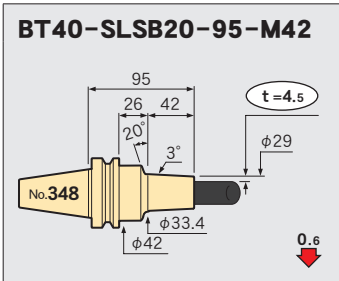

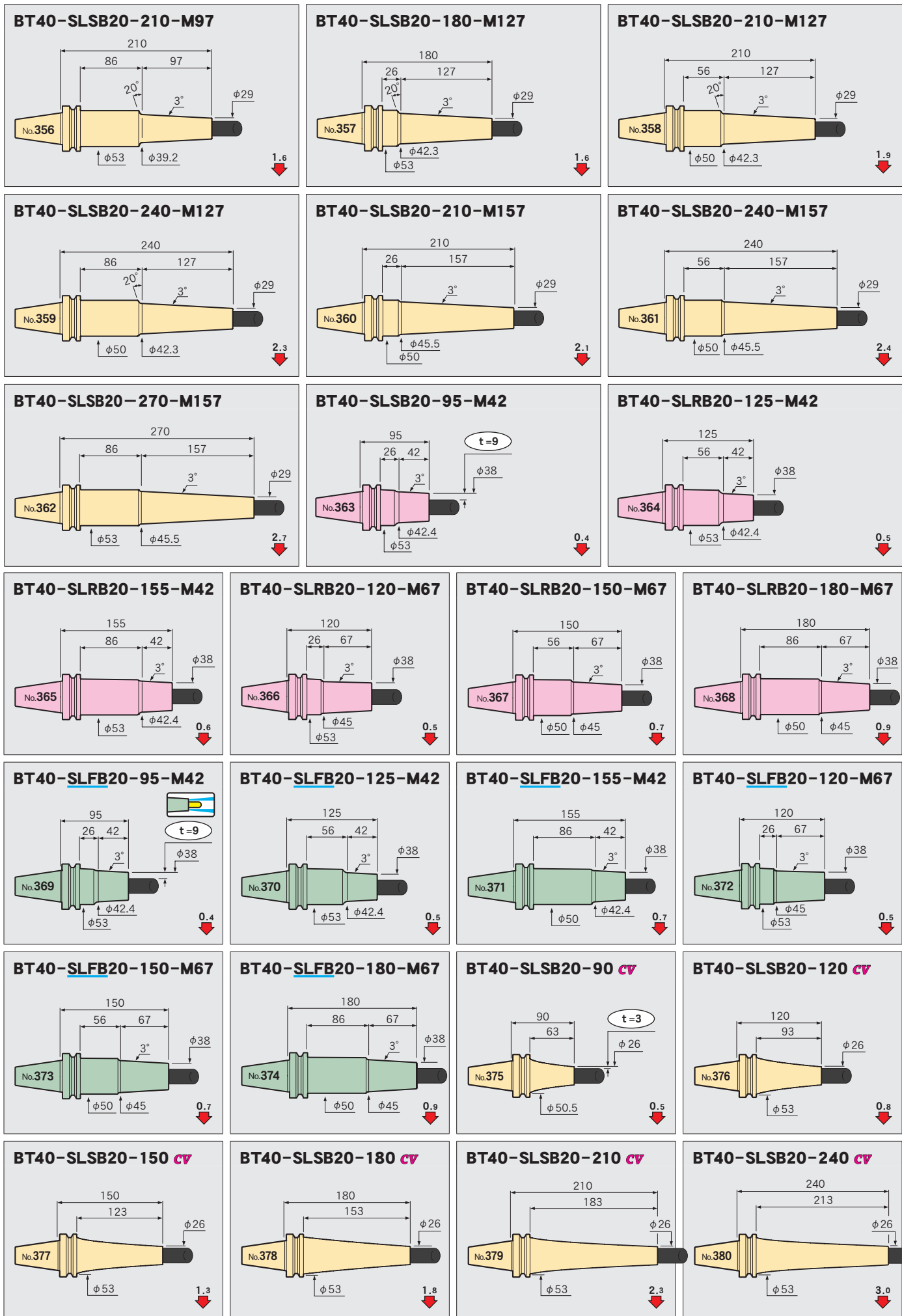

Feature

Shrink-fit Heater

MONO 3°
MONO CURVE

2PIECE type

UNO

HYPER
version

STRAIGHT
arbor

OTHERS

PERIPHERALS

Technical
Information

φ25

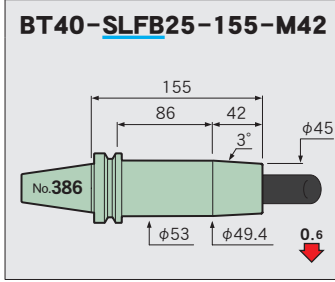
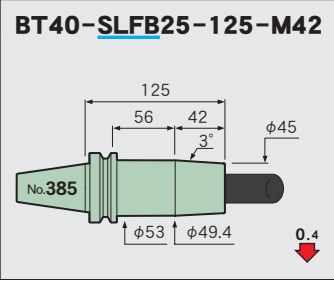
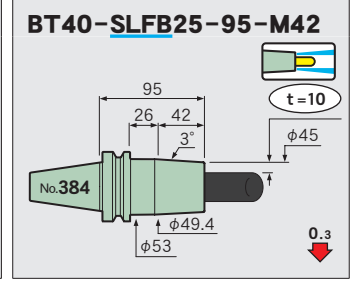
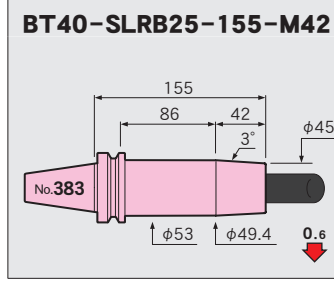
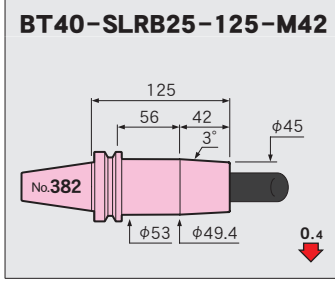
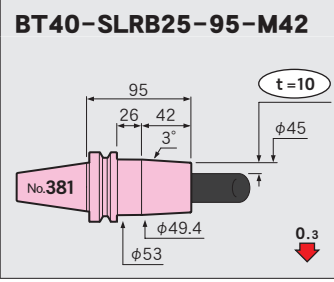

φ32

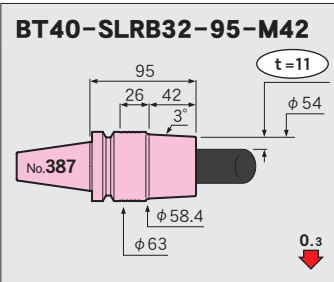

φ70 Nozzle (HRB-03S)
Required for shrinking the SLRB32.

CODE
HRB-NZL70

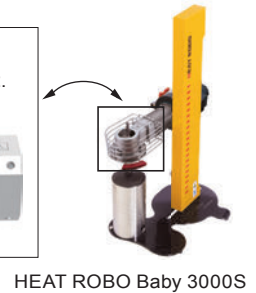

Feature
Shrink-fit Heater
MONO 3° MONO CURVE
MONO Series
2PIECE type
UNO
HYPER version
STRAIGHT arbor
OTHERS
PERIPHERALS
Technical Information

BT50

MONO 3°

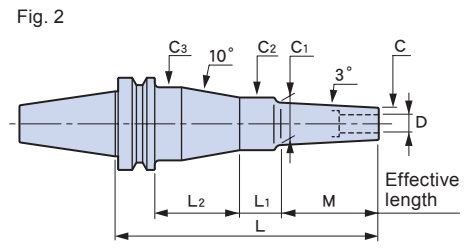
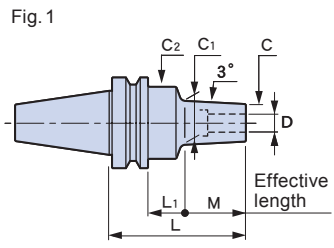

MONO CURVE CV

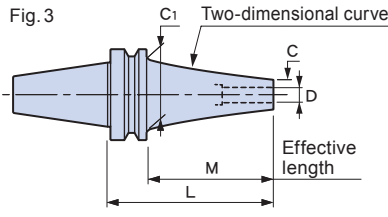

Option

- Retention knob → P.216

Caution

- Retention knob... Use a retention knob with hole, or remove the retention knob and heat it.
- Setting cutters... Be sure to insert the tool beyond the safety mark.



Compatibility table for HRD-01S

[○] Available [x] Not available

[▲] Usable by raising the heating unit. → P.233

CV : Curve Thickness

CODE	Fig.	φD	φC	t	L	M	L1	L2	φC1	φC2	φC3	H	h	Kg	N	S	Scale model
BT50-SLSA3-110-M 42	1	3	6	1.5	110	42	30	—	10.4	25	—	9	165	3.6	4.4	9.1	1
-135-M 67					135	67			13				190		5.1	14.7	4
-140-M 42					140	42	60		10.4				195	3.7	4.4	9.8	2
-165-M 67					165	67			13				220		5.2	15.9	5
-M 97						97	30		16.2	26					6	20.8	7
-170-M 42	2				170	42	33	57	10.4		40		225	4.1	4.6	9.9	3
-195-M 67					195	67			13	25	39		250	4	5.4	15.7	6
-M 97	1					97	60	—	16.2	26	—			3.8	6.1	22.3	8
-225-M 97	2				225		33	57			40		280	4.1	6.2	22.1	9
-SLRA3- 90-M 22	1	3	7.5	2.25	90	22	30	—	9.8	25	—	9	145	3.6	4.6	2.8	10
-110-M 42					110	42			11.9				165	3.6	4.9	5.3	13
-120-M 22					120	22	60		9.8				175	3.7	4.7	3.2	11
-135-M 67					135	67	30		14.5				190		5.4	8.9	16
-140-M 42					140	42	60		11.9	26			195	3.8	5	6	14
-150-M 22	2				150	22	33	57	9.8	25	39		205	4	4.9	3.2	12
-165-M 67	1				165	67	60	—	14.5		—		220	3.8	5.5	10	17
-M 97						97	30		17.7	26				3.7	6.1	13	19
-170-M 42	2				170	42	33	57	11.9	25	39		225	4	5.1	6	15
-195-M 67					195	67			14.5				250		5.7	9.8	18
-M 97	1					97	60	—	17.7	26	—			3.8	6.2	14.5	20
-M127						127	30		20.8	32					7.7	15.7	22
-225-M 97	2				225	97	33	57	17.7	25	39		280	4.1	6.3	14.4	21
-M127	1					127	60	—	20.8	36	—				7.7	16.3	23
-255-M127	2				255		30	60		32	46		310	4.4	8	16.5	24

CODE	Fig.	φD	φC	t	L	M	L ₁	L ₂	φC ₁	φC ₂	φC ₃	H	h	Kg	N	S	Scale model
BT50-SLFB3- 90-M 22	1	3	9.5	3.25	90	22	30	—	11.8	26	—	9	145	3.6	4.4	1.9	25
 -110-M 42					110	42			13.9				165	3.7	4.7	3.3	28
-120-M 22					120	22	60		11.8	25			175		4.5	2.4	26
-135-M 67					135	67	30		16.5	26			190		5.4	5.4	31
-140-M 42					140	42	60		13.9	25			195		4.8	4	29
-150-M 22	2				150	22	33	57	11.8		39		205	4	4.6	2.3	27
-165-M 67	1				165	67	60	—	16.5	26	—		220	3.8	5.5	6.4	32
-170-M 42	2				170	42	33	57	13.9	25	39		225	4	4.9	3.9	30
-195-M 67					195	67			16.5				250	4.1	5.7	6.4	33
BT50-SLSA4-110-M 42	1	4	7	1.5	110	42	30	—	11.4	25	—	12	165	3.6	5.1	7.2	34
-135-M 67					135	67			14				190		5.2	11.8	37
-140-M 42					140	42	60		11.4				195	3.7		8	35
-165-M 67					165	67			14				220			13	38
-M 97					97	30			17.2						6.1	16.7	40
-170-M 42	2				170	42	33	57	11.4		39		225	4	5.4	7.9	36
-195-M 67					195	67			14				250			12.8	39
-M 97	1				97	60	—		17.2	26	—			3.8	6.2	18.4	41
-225-M 97	2				225		33	57		25	39		280	4.1	6.3	18.2	42
-SLRA4- 90-M 22	1	4	10	3	90	22	30	—	12.3	25	—	12	145	3.6	4.7	1.7	43
-110-M 42					110	42			14.4				165		5.1	3.1	46
-120-M 22					120	22	60		12.3				175	3.7	4.8	2.2	44
-135-M 67					135	67	30		17				190		5.9	5.2	49
-140-M 42					140	42	60		14.4				195		5.2	3.9	47
BT50 -150-M 22	2				150	22	33	57	12.3		39		205	4	5	2.2	45
-165-M 67	1				165	67	60	—	17		—		220	3.8	5.9	6.4	50
-M 97					97	30			20.2					3.7	6.8	7.9	52
-170-M 42	2				170	42	33	57	14.4		39		225	4	5.4	3.8	48
-195-M 67					195	67			17				250	4.1	6.1	6.2	51
-M 97	1				97	60	—		20.2		—			3.8	6.9	9.7	53
-M127					127	30			23.3	32					9.2	9.4	55
-225-M 97	2				225	97		60	20.2	25	39		280	4.1	7.1		54
-M127	1				127	60	—		23.3	32	—			4	9.2	10.4	56
-255-M127	2				255		30	60			46		310	4.4	9.5	10.3	57
-SLFB4- 90-M 22	1	4	12	4	90	22	30	—	14.3	25	—	12	145	3.6	4.6	1.4	58
 -110-M 42					110	42			16.4				165	3.7	5	2.2	61
-120-M 22					120	22	60		14.3				175		4.6	1.9	59
-135-M 67					135	67	30		19	26			190		5.8	3.6	64
-140-M 42					140	42	60		16.4				195	3.8	5.1	2.9	62
-150-M 22	2				150	22	33	57	14.3	25	39		205	4	4.8	1.8	60
-165-M 67	1				165	67	60	—	19		—		220	3.8	5.9	4.8	65
-170-M 42	2				170	42	33	57	16.4	26	40		225	4.1	5.3	2.8	63
-195-M 67					195	67			19				250	4.2	6.1	4.5	66
-SLSA4-165 CV	3	4	7	1.5	165	127	—	—	85	—	—	12	220	5.2	15.4	1.8	67
-195 CV					195	157							250	5.3	15.9	2.6	68
-225 CV					225	187							280	5.5	16.4	3.8	69
-255 CV					255	217							310	5.6	16.9	5.7	70
-285 CV					285	247							340	6.4	19.5	5.9	71
-315 CV					315	277							370	8.3	26	7.7	72
BT50-SLSA6-110-M 42	1	6	9	1.5	110	42	30	—	13.4	25	—	18	165	3.6	5.4	4.8	73
-135-M 67					135	67			16				190	3.7	6.4	8.1	76
-140-M 42					140	42	60		13.4				195		5.4	5.7	74
-165-M 67					165	67			16				220	3.8	6.5	9.4	77
-M 97					97	30			19.2	32				3.7	8.3	11	79
-170-M 42	2				170	42	33	57	13.4	25	39		225	4	5.6	5.6	75
-195-M 67					195	67			16				250		6.6	9.2	78
-M 97	1				97	60	—		19.2	32	—			3.9	8.2	11.7	80
-225-M 97	2				225		30	60			46		280	4.3	8.5		81

CODE	Fig.	φD	φC	t	L	M	L ₁	L ₂	φC ₁	φC ₂	φC ₃	H	h	Kg	N	S	Scale model
BT50-SLSB6-110-M 42	1	6	10	2	110	42	30	—	14.4	25	—	18	165	3.6	6	3.7	○
-135-M 67					135	67			17				190	3.7	7.4	6.2	85
-140-M 42					140	42	60		14.4				195		6.1	4.6	83
-165-M 67					165	67			17				220	3.8	7.4	7.6	86
-M 97						97	30		20.2	32					9.6	8.5	88
-170-M 42	2				170	42	33	57	14.4	25	39		225	4	6.2	4.4	84
-195-M 67					195	67			17				250	4.1	7.6	7.3	87
-M 97	1				97	60	—		20.2	32	—			3.9	9.6	9.2	89
BT50 -M127					127	30			23.3					3.8	11.3	11.1	91
-225-M 97	2				225	97		60	20.2		46		280	4.3	9.9	9.2	90
-M127	1				127	60	—		23.3		—			4	11.2	12.1	92
-M157					157	30			26.5					3.9	13	13.3	94
-255-M127	2				255	127		60	23.3	32	46		310	4.4	11.5	12	▲
-M157	1				157	60	—		26.5		—			4.1	12.9	14.7	95
-285-M157	2				285		30	60			46		340	4.5	13.2	14.5	96
-SLRB6- 90-M 22	1	6	14	4	90	22	30	—	16.3	32	—	18	145	3.7	5.5	1	○
-110-M 42					110	42			18.4				165		6.6	1.6	100
-120-M 22					120	22	60		16.3				175	3.8	5.5	1.2	98
-135-M 67					135	67	30		21				190		8	2.6	103
-140-M 42					140	42	60		18.4				195	3.9	6.6	1.9	101
-150-M 22	2				150	22	30	60	16.3		46		205	4.2	5.8	1.2	99
-165-M 67	1				165	67	60	—	21		—		220	3.9	8	3.1	104
-170-M 42	2				170	42	30	60	18.4		46		225	4.3	6.9	1.9	102
-195-M 67					195	67			21				250		8.3	3	105
-SLFB6- 90-M 22	1	6	14	4	90	22	30	—	16.3	32	—	18	145	3.7	5.5	1	○
 -110-M 42					110	42			18.4				165		6.6	1.6	109
-120-M 22					120	22	60		16.3				175	3.8	5.5	1.2	107
-135-M 67					135	67	30		21				190		8	2.6	112
-140-M 42					140	42	60		18.4				195	3.9	6.6	1.9	110
-150-M 22	2				150	22	30	60	16.3		46		205	4.2	5.8	1.2	108
-165-M 67	1				165	67	60	—	21		—		220	3.9	8	3.1	113
-170-M 42	2				170	42	30	60	18.4		46		225	4.3	6.9	1.9	111
-195-M 67					195	67			21				250		8.3	3	114
-SLSA6-165 cv	3	6	9	1.5	165	127	—	—	85	—	—	18	220	5.1	15.1	1.5	○
-195 cv					195	157							250	5.2	15.5	2.4	116
-225 cv					225	187							280	5.7	16.8	2.9	117
-255 cv					255	217							310	5.9	18.4	4	▲
-285 cv					285	247							340	6.2	19.5	5.2	119
-315 cv					315	277							370	8.4	26.8	6.9	120
BT50-SLSA8-110-M 42	1	8	11	1.5	110	42	30	—	15.4	25	—	24	165	3.6	6.9	3.5	○
-135-M 67					135	67			18	32			190	3.7	8.7	5.4	124
-140-M 42					140	42	60		15.4	25			195		6.9	4.4	122
-165-M 67					165	67			18	32			220	3.9	8.6	5.9	125
-M 97						97	30		21.2					3.8	10.8	7.9	127
-170-M 42	2				170	42	33	57	15.4	25	39		225	4	7.2	4.3	123
-195-M 67					195	67	30	60	18	32	46		250	4.3	8.9	5.9	126
-M 97	1				97	60	—		21.2		—			3.9	10.7	8.7	128
-225-M 97	2				225		30	60			46		280	4.3	11	8.6	129

Feature

Shrink-fit Heater

MONO 3°
MONO CURVE

MONO Series

2PIECE type

UNO



HYPER
version

STRAIGHT
arbor

OTHERS

PERIPHERALS

Technical
Information



Feature	CODE	Fig.	φD	φC	t	L	M	L ₁	L ₂	φC ₁	φC ₂	φC ₃	H	h	Kg	N	S	Scale model	
Shrink-fit Heater	BT50-SLSB8-110-M 42	1	8	13	2.5	110	42	30	—	17.4	32	—	24	165	3.7	7.7	2.1	○	130
	-135-M 67					135	67			20				190		9.8	3.5		133
	-140-M 42					140	42	60		17.4				195	3.8	7.6	2.4		131
	-165-M 67					165	67			20				220	3.9	9.8	4		134
	-M 97						97	30		23.2					3.8	12.4	5.3		136
	-170-M 42	2				170	42		60	17.4		46		225	4.3	7.9	2.4		132
	-195-M 67					195	67			20				250		10.1	4		135
	BT50 -M 97	1					97	60	—	23.2		—			4	12.3	6.1		137
	-M127						127	30		26.3					3.9	14.9	7.1		139
	-225-M 97	2				225	97		60	23.2		46		280	4.4	12.6	6		138
	-M127	1					127	60	—	26.3		—			4	14.9	8.2		140
	-M157						157	30		29.5	42					17.5	8		142
	-255-M127	2				255	127		60	26.3	32	46		310	4.5	15.2	8.1	▲	141
	-M157	1					157	60	—	29.5	42	—			4.3	17.5	8.5		143
-285-M157	2				285		28	62				56	340	4.9	17.8			144	
2PIECE type	-SLRB8- 90-M 22	1	8	18	5	90	22	30	—	20.3	32	—	24	145	3.7	6	0.7	×	145
	-110-M 42					110	42			22.4				165		7.7	1.1	○	148
	-120-M 22					120	22	60		20.3				175	3.8	5.9	0.9	×	146
	-135-M 67					135	67	30		25				190		9.8	1.7	○	151
	-140-M 42					140	42	60		22.4				195	3.9	7.7	1.4		149
	-150-M 22	2				150	22	30	60	20.3		46		205	4.3	6.2	0.9	×	147
	-165-M 67	1				165	67	60	—	25		—		220	4	9.8	2.2	○	152
	-170-M 42	2				170	42	30	60	22.4	32	46		225	4.3	8	1.4		150
	-195-M 67					195	67			25				250	4.4	10.1	2.2		153
	UNO	-SLFB8- 90-M 22	1	8	18	5	90	22	30	—	20.3	32	—	24	145	3.7	6	0.7	×
 -110-M 42						110	42			22.4				165		7.7	1.1	○	157
-120-M 22						120	22	60		20.3				175	3.8	5.9	0.9	×	155
-135-M 67						135	67	30		25				190		9.8	1.7	○	160
-140-M 42						140	42	60		22.4				195	3.9	7.7	1.4		158
-150-M 22		2				150	22	30	60	20.3		46		205	4.3	6.2	0.9	×	156
-165-M 67		1				165	67	60	—	25		—		220	4	9.8	2.2	○	161
-170-M 42		2				170	42	30	60	22.4		46		225	4.3	8	1.4		159
-195-M 67						195	67			25				250	4.4	10.1	2.2		162
STRAIGHT anbor		-SLSA8-165 CV	3	8	11	1.5	165	127	—	—	85	—	—	24	220	4.9	14.7	1.4	○
	-195 CV					195	157							250	5.3	16.1	1.9		164
	-225 CV					225	187							280	5.8	17.7	2.3		165
	-255 CV					255	217							310		17.9	3.7	▲	166
	-285 CV					285	247							340	6	19.1	4.9		167
	-315 CV					315	277							370	8.4	28	5		168
OTHERS	-SLRA8-195 CV	3	8	16	4	195	157	—	—	85	—	—	24	250	5.4	17.3	1.1	○	169
	-225 CV					225	187							280	5.6	18.3	1.5		170
	-255 CV					255	217							310	5.8	19.1	2.2	▲	171
	-285 CV					285	247							340	5.9	19.9	3		172
PERIPHERALS	-SLFA8-195 CV	3	8	16	4	195	157	—	—	85	—	—	24	250	5.4	17.3	1.1	○	173
	 -225 CV					225	187							280	5.6	18.3	1.5		174
	-255 CV					255	217							310	5.8	19.1	2.2	▲	175
	-285 CV					285	247							340	5.9	19.9	3		176

CODE	Fig.	φD	φC	t	L	M	L ₁	L ₂	φC ₁	φC ₂	φC ₃	H	h	Kg	N	S	Scale model	Feature	
BT50-SLSA10-110-M 42	1	10	13	1.5	110	42	30	—	17.4	25	—	30	165	3.6	7.9	2.6	○	177	Shrink-fit Heater
-135-M 67					135	67			20	32			190	3.7	10.4	4		180	
-140-M 42					140	42	60		17.4	25			195		7.8	3.7		178	
-165-M 67					165	67			20	32			220	3.9	10.4	4.6		181	
-M 97						97	30		23.2					3.8	13.6	6		183	
-170-M 42	2				170	42	33	57	17.4	25	39		225	4	8.1	3.5		179	
-195-M 67					195	67	30	60	20	32	46		250	4.3	10.7	4.6		182	
-M 97	1					97	60	—	23.2		—			3.9	13.5	6.9		184	
-225-M 97	2				225		30	60			46		280	4.4	13.8	6.8	▲	185	
-SLSB10-110-M 42	1	10	16	3	110	42	30	—	20.4	32	—	30	165	3.7	8.6	1.4	○	186	
-135-M 67					135	67			23				190	3.8	11.7	2.4		189	
-140-M 42					140	42	60		20.4				195	3.9	8.6	1.8		187	
BT50 -165-M 67					165	67			23				220		11.7	3		190	
-M 97						97	30		26.2						15.4	3.7		192	
-170-M 42	2				170	42		60	20.4		46		225	4.3	8.9	1.8		188	
-195-M 67					195	67			23				250		12	3		191	
-M 97	1					97	60	—	26.2		—			4	15.3	4.5		193	
-M127						127	30		29.3	42					20			195	
-225-M 97	2				225	97		60	26.2	32	46		280	4.4	15.6	4.4	▲	194	
-M127	1					127	60	—	29.3	42	—			4.2	20.6	4.9		196	
-M157						157	30		32.5					4.1	23.7	5.6		198	
-255-M127	2				255	127	28	62	29.3		56		310	4.8	21.1	4.9		197	
-M157	1					157	60	—	32.5		—			4.4	24.3	6.1		199	
-285-M157	2				285		28	62			56		340	5	24.8			200	
-SLRB10- 90-M 22	1	10	22	6	90	22	30	—	24.3	32	—	30	145	3.7	6.2	0.6	×	201	UNO
-110-M 42					110	42			26.4				165	3.8	8.7	0.8	○	204	
-120-M 22					120	22	60		24.3				175	3.9	6.2		×	202	
-135-M 67					135	67	30		29	42			190		11.8	1.1	○	207	
-140-M 42					140	42	60		26.4	32			195		8.6	1.2		205	
-150-M 22	2				150	22	30	60	24.3		46		205	4.3	6.5	0.8	×	203	
-165-M 67	1				165	67	60	—	29	42	—		220	4.1	11.7	1.3	○	208	
-170-M 42	2				170	42	30	60	26.4	32	46		225	4.3	8.9	1.2		206	
-195-M 67					195	67	28	62	29	42	56		250	4.7	12	1.3		209	
-SLFB10- 90-M 22	1	10	22	6	90	22	30	—	24.3	32	—	30	145	3.7	6.2	0.6	×	210	
 -110-M 42					110	42			26.4				165	3.8	8.7	0.8	○	213	
-120-M 22					120	22	60		24.3				175	3.9	6.2		×	211	
-135-M 67					135	67	30		29	42			190		11.8	1.1	○	216	
-140-M 42					140	42	60		26.4	32			195		8.6	1.2		214	
-150-M 22	2				150	22	30	60	24.3	32	46		205	4.3	6.5	0.8	×	212	
-165-M 67	1				165	67	60	—	29	42	—		220	4.1	11.7	1.3	○	217	
-170-M 42	2				170	42	30	60	26.4	32	46		225	4.3	8.9	1.2		215	
-195-M 67					195	67	28	62	29	42	56		250	4.7	12	1.3		218	
-SLSA10-165 CV	3	10	13	1.5	165	127	—	—	85	—	—	30	220	4.9	14.9	1.2	○	219	PERIPHERALS
-195 CV					195	157							250	5.5	16.9	1.5		220	
-225 CV					225	187							280	5.4	16.8	2.4	▲	221	
-255 CV					255	217							310	6.1	19.8	2.6		222	
-285 CV					285	247							340	6.3	21.2	3.7		223	
-315 CV					315	277							370	8.4	28.6	4.6		224	

CODE	Fig.	φD	φC	t	L	M	L ₁	L ₂	φC ₁	φC ₂	φC ₃	H	h	Kg	N	S	Scale model	
BT50-SLRA10-165 CV	3	10	19	4.5	165	127	—	—	85	—	—	30	220	5.1	15.9	0.7	×	225
-195 CV					195	157	—	—					250	5.2	16.6	1.1	○	226
-225 CV					225	187	—	—					280	5.9	19.7	1.2	▲	227
-255 CV					255	217	—	—					310	6.1	20.3	1.7	▲	228
-285 CV					285	247	—	—					340	6.2	21.1	2.4	▲	229
-SLFA10-165 CV	3	10	19	4.5	165	127	—	—	85	—	—	30	220	5.1	15.9	0.7	×	230
-195 CV					195	157	—	—					250	5.2	16.6	1.1	○	231
-225 CV					225	187	—	—					280	5.9	19.7	1.2	▲	232
-255 CV					255	217	—	—					310	6.1	20.3	1.7	▲	233
-285 CV					285	247	—	—					340	6.2	21.1	2.4	▲	234
BT50-SLSA12-110-M 42	1	12	15	1.5	110	42	30	—	19.4	32	—	30	165	3.7	9.5	1.9	○	235
-135-M 67					135	67	—	—					190	—	13.1	3.3	○	238
-140-M 42	1	12	15	1.5	140	42	60	—	19.4	—	—	30	195	3.8	9.4	2.3	○	236
-165-M 67					165	67	—	—					220	3.9	13	3.9	○	239
-M 97	2	12	15	1.5	97	30	—	—	25.2	—	—	30	—	3.8	17.7	4.9	○	241
-170-M 42					170	42	60	60					19.4	46	225	4.3	9.7	2.3
-195-M 67	1	12	15	1.5	195	67	—	—	22	—	—	30	250	—	13.3	3.9	○	240
-M 97					97	60	—	—					25.2	—	4	17.7	5.9	○
-225-M 97	2	12	15	1.5	225	—	30	60	—	—	46	280	4.4	18	5.8	▲	243	
-SLSB12-110-M 42	1	12	19	3.5	110	42	30	—	23.4	32	—	30	165	3.7	10.4	1.1	○	244
-135-M 67					135	67	—	—					190	3.8	14.6	1.9	○	247
-140-M 42					140	42	60	—					195	3.9	10.3	1.6	○	245
-165-M 67					165	67	—	—					220	—	14.5	2.5	○	248
-M 97					97	30	—	—					29.2	42	20.5	2.4	○	250
-170-M 42	2	12	19	3.5	170	42	60	60	23.4	32	46	225	4.3	10.6	1.5	○	246	
-195-M 67					195	67	—	—	26	250	4.4	14.8	2.4	○	249			
BT50 -M 97	1	12	19	3.5	97	60	—	—	29.2	42	—	30	4.2	21.1	2.7	○	251	
-M127					127	30	—	—					32.3	4.1	25.5	3.3	○	253
-225-M 97	2	12	19	3.5	225	97	28	62	29.2	—	56	280	4.8	21.6	2.8	▲	252	
-M127					127	60	—	—	32.3	—	4.3	26.1	3.7	○	254			
-M157	1	12	19	3.5	157	30	—	—	35.5	—	—	30	—	30.6	4.1	○	256	
-255-M127					255	127	28	62					32.3	56	310	4.9	26.7	3.7
-M157	1	12	19	3.5	157	60	—	—	35.5	—	—	30	4.5	31.1	4.7	○	257	
-285-M157					285	—	28	62					—	56	340	5.1	31.7	—
-SLRB12- 90-M 22	1	12	26	7	90	22	30	—	28.3	42	—	30	145	3.7	9.5	0.4	×	259
-110-M 42					110	42	—	—					165	3.8	11.4	0.6	○	262
-120-M 22					120	22	60	—					175	4	10.1	0.5	○	260
-135-M 67					135	67	30	—					190	—	15.5	0.8	○	265
-140-M 42					140	42	60	—					195	4.1	11.9	0.7	○	263
-150-M 22	2	12	26	7	150	22	28	62	28.3	—	56	205	4.6	10.7	0.5	○	261	
-165-M 67					165	67	60	—	33	—	220	4.2	16.1	1	○	266		
-170-M 42	2	12	26	7	170	42	28	62	30.4	—	56	225	4.7	12.5	0.7	○	264	
-195-M 67					195	67	—	—	33	—	250	4.8	16.7	1.1	○	267		
-SLFB12- 90-M 22	1	12	26	7	90	22	30	—	28.3	42	—	30	145	3.7	9.5	0.4	×	268
-110-M 42					110	42	—	—					165	3.8	11.4	0.6	○	271
-120-M 22					120	22	60	—					175	4	10.1	0.5	○	269
-135-M 67					135	67	30	—					190	—	15.5	0.8	○	274
-140-M 42					140	42	60	—					195	4.1	11.9	0.7	○	272
-150-M 22	2	12	26	7	150	22	28	62	28.3	—	56	205	4.6	10.7	0.5	○	270	
-165-M 67					165	67	60	—	33	—	220	4.2	16.1	1	○	275		
-170-M 42	2	12	26	7	170	42	28	62	30.4	—	56	225	4.7	12.5	0.7	○	273	
-195-M 67					195	67	—	—	33	—	250	4.8	16.7	1.1	○	276		

CODE	Fig.	φD	φC	t	L	M	L ₁	L ₂	φC ₁	φC ₂	φC ₃	H	h	Kg	N	S	Scale model	Feature				
BT50-SLSA12-165 CV	3	12	15	1.5	165	127	—	—	84	—	—	30	220	4.8	14.6	1.2		277	Shrink-fit Heater			
-195 CV					195	157	—	—	85	—	—	30	250	5.6	17.6	—	—	—			278	
-225 CV					225	187	—	—	—	—	—	30	280	5.8	18.5	1.8	—	—			279	
-255 CV					255	217	—	—	—	—	—	30	310	6	19.3	2.6	—	—			280	
-285 CV					285	247	—	—	—	—	—	30	340	6.2	21.2	3.5	—	—			281	
-315 CV					315	277	—	—	—	—	—	30	370	8.5	29.2	3.6	—	—			282	
-SLRA12-165 CV	3	12	22	5	165	127	—	—	85	—	—	30	220	5.1	16.1	0.7		283	MONO 3° MONO CURVE			
-195 CV					195	157	—	—	—	—	30	250	5.6	18	0.8	—	—			284		
BT50 -225 CV					225	187	—	—	—	—	30	280	—	18.6	1.3	—	—			285		
-255 CV					255	217	—	—	—	—	30	310	5.8	20.7	1.6	—	—			286		
-285 CV					285	247	—	—	—	—	30	340	6.1	22.4	2.1	—	—			287		
-SLFA12-165 CV	3	12	22	5	165	127	—	—	85	—	—	30	220	5.1	16.1	0.7		288	MONO Series			
-195 CV					195	157	—	—	—	—	30	250	5.6	18	0.8	—	—			289		
-225 CV					225	187	—	—	—	—	30	280	—	18.6	1.3	—	—			290		
-255 CV					255	217	—	—	—	—	30	310	5.8	20.7	1.6	—	—			291		
-285 CV					285	247	—	—	—	—	30	340	6.1	22.4	2.1	—	—			292		
BT50-SLSB16-110-M 42	1	16	24	4	110	42	30	—	28.4	42	—	32	165	3.8	15	0.7		293	2PIECE type			
-135-M 67					135	67	—	—	31	—	—	32	190	3.9	21.9	1.1		—		—	296	
-140-M 42					140	42	60	—	28.4	—	—	32	195	4	15.6	0.9		—		—	294	
-165-M 67					165	67	—	—	31	—	—	32	220	4.1	22.5	1.4		—		—	297	
-M 97					—	97	30	—	34.2	—	—	32	—	4	30.2	1.7		—		—	299	
-170-M 42					2	170	42	28	62	28.4	—	56	32	225	4.6	16.2		0.9		—	—	295
-195-M 67						195	67	—	—	31	—	—	32	250	4.7	23		1.4		—	—	298
-M 97					1	97	60	—	34.2	—	—	—	32	—	4.3	30.7		2		—	—	300
-M127						127	30	—	37.3	53	—	—	32	—	4.2	38.5		2.1		—	—	302
-225-M 97					2	225	97	28	62	34.2	42	56	32	280	4.9	31.3		—		—	—	301
-M127	1	127	60	—		37.3	53	—	—	32	—	4.6	39	2.3	—	—	303					
-M157		2	157	30	—	40.5	—	—	—	32	—	4.4	46.8	2.6	—	—	305					
-255-M127	2		255	127	28	62	37.3	—	67	32	310	5.5	39.6	2.3	—	—	304					
-M157		1	157	60	—	40.5	—	—	—	32	—	4.8	47.3	2.8	—	—	306					
-285-M157	2		285	—	28	62	—	67	32	340	5.7	47.9	2.9	—	—	—	307					
-SLRB16- 90-M 22		1	16	32	8	90	22	30	—	34.3	42	—	32	145	3.8	9.6	0.3		308	HYPER version		
-110-M 42	110					42	—	—	36.4	—	—	32	165	3.9	15.1	0.5	—		—		311	
-120-M 22	120					22	60	—	34.3	—	—	32	175	4	10.1	—	—		—		309	
-135-M 67	135					67	30	—	39	—	—	32	190	4.1	22	0.6	—		—		314	
-140-M 42	140					42	60	—	36.4	—	—	32	195	4.2	15.7	—	—		—		312	
-150-M 22	2					150	22	28	62	34.3	—	56	32	205	4.6	10.7	0.5		—		—	310
-165-M 67						1	165	67	60	—	39	—	—	32	220	4.3	22.6		0.9		—	—
-170-M 42	2						170	42	28	62	36.4	—	56	32	225	4.8	16.2		0.7		—	—
-195-M 67						1	195	67	—	—	39	—	—	32	250	4.9	23.2		0.9		—	—
-SLFB16- 90-M 22	1	16	32	8	90		22	30	—	34.3	42	—	32	145	3.8	9.6	0.3		317	STRAIGHT arbor		
-110-M 42					110	42	—	—	36.4	—	—	32	165	3.9	15.1	0.5	—		—		320	
-120-M 22					120	22	60	—	34.3	—	—	32	175	4	10.1	—	—		—		318	
-135-M 67					135	67	30	—	39	—	—	32	190	4.1	22	0.6	—		—		323	
-140-M 42					140	42	60	—	36.4	—	—	32	195	4.2	15.7	—	—		—		321	
-150-M 22					2	150	22	28	62	34.3	—	56	32	205	4.6	10.7	0.5		—		—	319
-165-M 67						1	165	67	60	—	39	—	—	32	220	4.3	22.6		0.9		—	—
-170-M 42					2		170	42	28	62	36.4	—	56	32	225	4.8	16.2		0.7		—	—
-195-M 67						1	195	67	—	—	39	—	—	32	250	4.9	23.2		0.9		—	—
-SLSB16-165 CV	3	16	21	2.5	165		127	—	—	85	—	—	32	220	5.4	17.8	0.6		326	PERIPHERALS		
-195 CV					195	157	—	—	—	—	32	250	—	17.7	1.1	—	—		—		327	
-225 CV					225	187	—	—	—	—	32	280	6.3	21.1	1.2	—	—		—		328	
-255 CV					255	217	—	—	—	—	32	310	6.1	20.9	2	—	—		—		329	
-285 CV					285	247	—	—	—	—	32	340	7	24.3	—	—	—		—		330	
-315 CV					315	277	—	—	—	—	32	370	8.6	30.9	2.6	—	—		—		331	

Feature
Shrink-fit Heater
MONO 3° MONO CURVE
MONO Series
2PIECE type
UNO
HYPER version
STRAIGHT anbor
OTHERS
PERIPHERALS
Technical Information

CODE	Fig.	φD	φC	t	L	M	L ₁	L ₂	φC ₁	φC ₂	φC ₃	H	h	Kg	N	S	Scale model
BT50-SLSB20-110-M 42	1	20	29	4.5	110	42	30	—	33.4	42	—	40	165	3.8	16.8	0.5	332
-135-M 67					135	67			36				190	3.9	27.1	0.9	335
-140-M 42					140	42	60		33.4				195	4.1	17.4	0.8	333
BT50 -165-M 67					165	67			36				220	4.2	27.7	1.2	336
-M 97						97	30		39.2	53				4.1	39.4	1.1	338
-170-M 42	2				170	42	28	62	33.4	42	56		225	4.7	18	0.8	334
-195-M 67					195	67			36				250	4.8	28.2	1.2	337
-M 97	1					97	60	—	39.2	53	—			4.5	40	1.3	339
-M127						127	30		42.3					4.3	52.6	1.5	341
-225-M 97	2				225	97	28	62	39.2		67		280	5.4	40.6	1.3	340
-M127	1					127	60	—	42.3		—			4.7	53.2	1.8	342
-M157						157	30		45.5					4.6	65	1.7	344
-255-M127	2				255	127	28	62	42.3		67		310	5.6	53.7		343
-M157	1					157	60	—	45.5		—			5	65.5	2.2	345
-285-M157	2				285		28	62			67		340	5.9	66.1		346
-SLRB20-110-M 42	1	20	38	9	110	42	30	—	42.4	53	—	40	165	4	16.9	0.3	347
-135-M 67					135	67			45				190	4.2	27.2	0.4	350
-140-M 42					140	42	60		42.4				195	4.4	17.5		348
-165-M 67					165	67			45				220	4.6	27.8	0.6	351
-170-M 42	2				170	42	28	62	42.4		67		225	5.3	18.1	0.4	349
-195-M 67					195	67			45				250	5.5	28.4	0.6	352
-SLFB20-110-M 42	1	20	38	9	110	42	30	—	42.4	53	—	40	165	4	16.9	0.3	353
 -135-M 67					135	67			45				190	4.2	27.2	0.4	356
-140-M 42					140	42	60		42.4				195	4.4	17.5		354
-165-M 67					165	67			45				220	4.6	27.8	0.6	357
-170-M 42	2				170	42	28	62	42.4		67		225	5.3	18.1	0.4	355
-195-M 67					195	67			45				250	5.5	28.4	0.6	358
-SLSB20-165 CV	3	20	26	3	165	127	—	—	85	—	—	40	220	5.4	17.4	0.6	359
-195 CV					195	157							250	6.1	20.8	0.7	360
-225 CV					225	187							280	5.8	20.5	1.2	361
-255 CV					255	217							310	6.7	23.9	1.3	362
-285 CV					285	247							340	7	25.4	1.7	363
-315 CV					315	277							370	8.9	32.4	2.3	364
BT50-SLRB25-110-M 42	1	25	45	10	110	42	30	—	49.4	53	—	45	165	4.1	19	0.3	365
-140-M 42					140		60						195	4.5	19.6	0.4	366
-170-M 42	2				170		28	62			67			5.3	20.2		367
-SLFB25-110-M 42	1	25	45	10	110	42	30	—	49.4	53	—	45	165	4.1	19	0.3	368
 -140-M 42					140		60						195	4.5	19.6	0.4	369
-170-M 42	2				170		28	62			67			5.4	20.2		370
BT50-SLRB32-110-M 42	1	32	54	11	110	42	30	—	58.4	63	—	50	160	4.0	11.2	0.2	371
-140-M 42					140		60						171	4.6	13.4	0.3	372
-170-M 42	2				170		28	62			77			5.8	19.6		373

■ Cleaning tool for a spindle taper hole, STAR DUST

CODE
CLT-NT50-G3

Ⓟ P.226



■ φ70 Nozzle (HRB-03S)
Required for shrinking the SLRB32.

CODE
HRB-NZL70



HEAT ROBO Baby 3000S

φ 3

BT50-SLSA3-110-M42

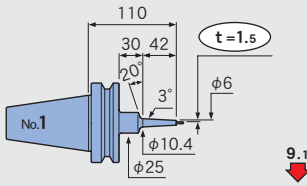

9.1

BT50-SLSA3-140-M42

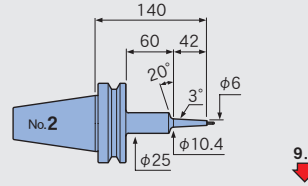

9.8

BT50-SLSA3-170-M42

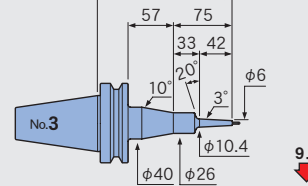

9.9

BT50-SLSA3-135-M67

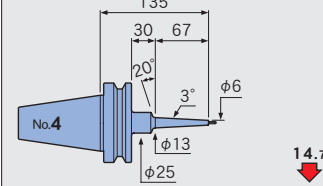

14.7

BT50-SLSA3-165-M67

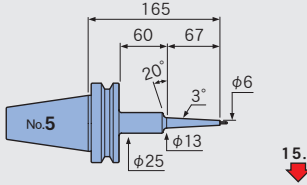

15.9

BT50-SLSA3-195-M67

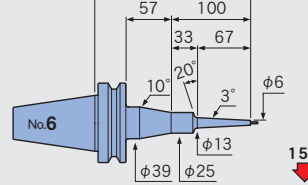

15.7

BT50-SLSA3-165-M97

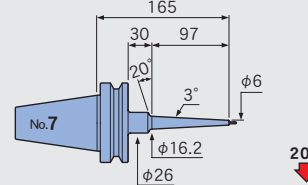

20.8

BT50-SLSA3-195-M97

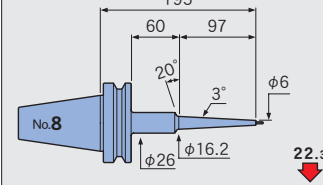

22.3

BT50-SLSA3-225-M97

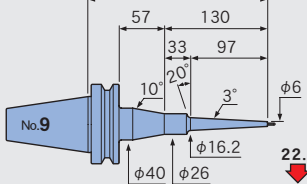

22.1

BT50-SLRA3-90-M22

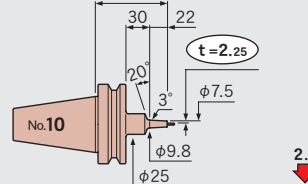

2.8

BT50-SLRA3-120-M22

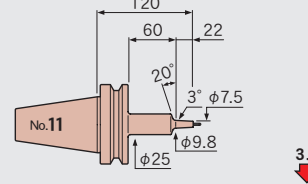

3.2

BT50-SLRA3-150-M22

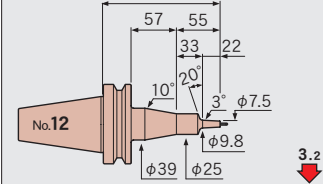

3.2

BT50-SLRA3-110-M42

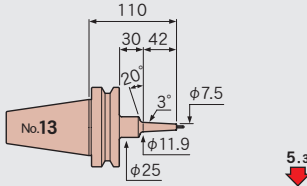

5.3

BT50-SLRA3-140-M42

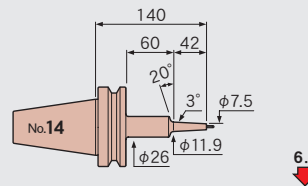

6.0

BT50-SLRA3-170-M42

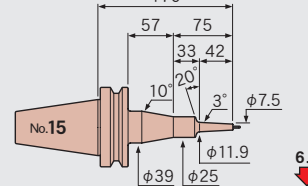

6.0

BT50-SLRA3-135-M67

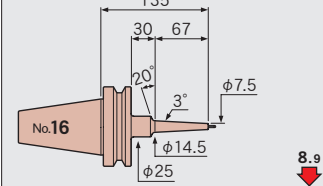

8.9

BT50-SLRA3-165-M67

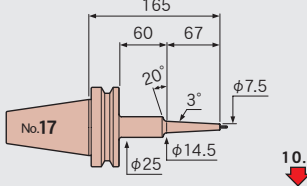

10.0

BT50-SLRA3-195-M67

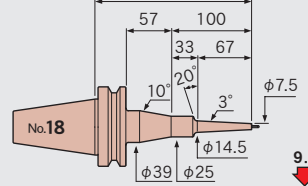

9.8

BT50-SLRA3-165-M97

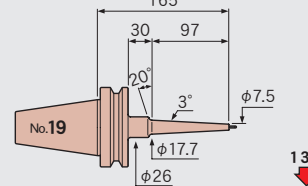

13.0

BT50-SLRA3-195-M97

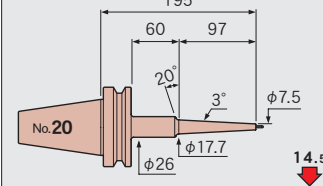

14.5

BT50-SLRA3-225-M97

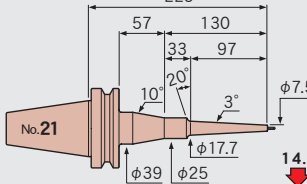

14.4

BT50-SLRA3-195-M127

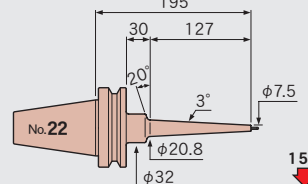

15.7

BT50-SLRA3-225-M127

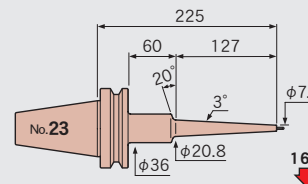

16.3

BT50-SLRA3-255-M127

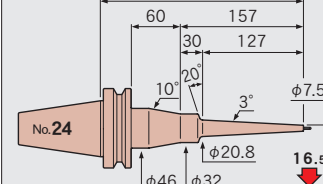

16.5

BT50-SLFB3-90-M22

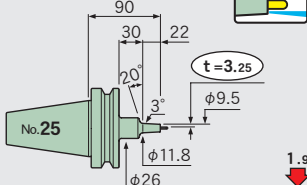

1.9

BT50-SLFB3-120-M22

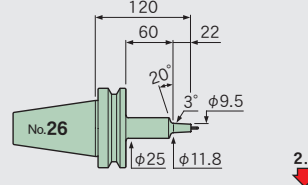

2.4

BT50-SLFB3-150-M22

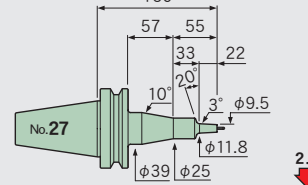

2.3

BT50-SLFB3-110-M42

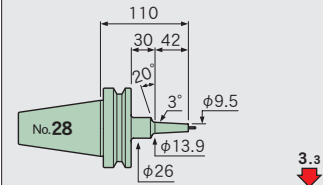

3.3

Feature
Shrink-fit Heater
MONO 3° MONO CURVE
MONO Series
2PIECE type
UNO
HYPER version
STRAIGHT anbor
OTHERS
PERIPHERALS
Technical Information

BT50-SLFB3-140-M42

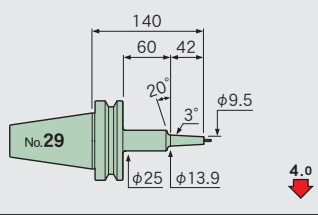

BT50-SLFB3-170-M42

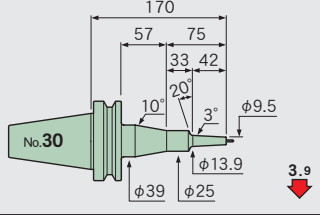

BT50-SLFB3-135-M67

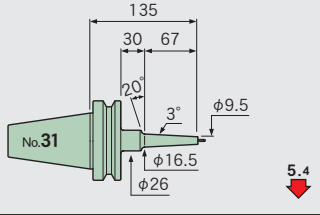

BT50-SLFB3-165-M67

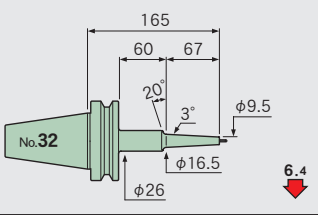

BT50-SLFB3-195-M67

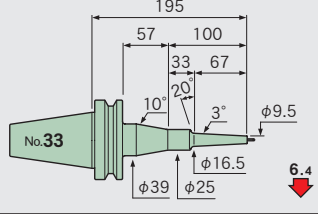

φ4

BT50-SLSA4-110-M42

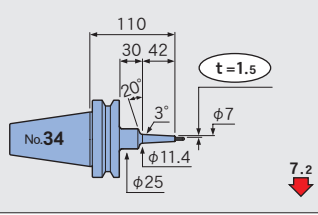

BT50-SLSA4-140-M42

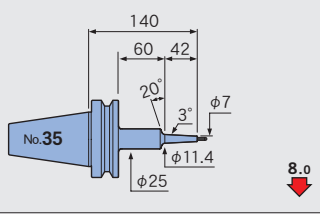

BT50-SLSA4-170-M42

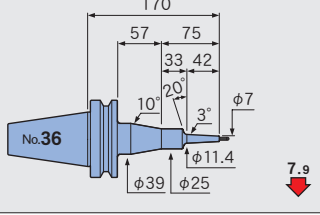

BT50-SLSA4-135-M67

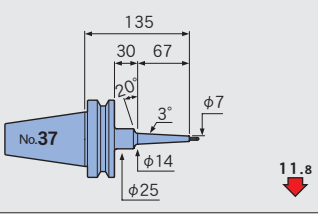

BT50-SLSA4-165-M67

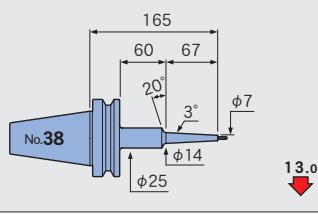

BT50-SLSA4-195-M67

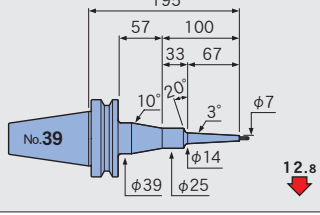

BT50-SLSA4-165-M97

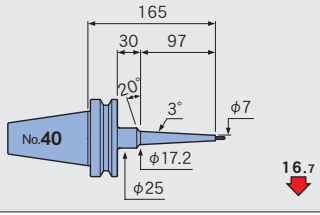

BT50-SLSA4-195-M97

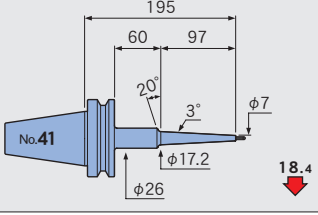

BT50-SLSA4-225-M97

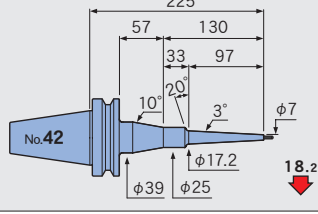

BT50-SLRA4-90-M22

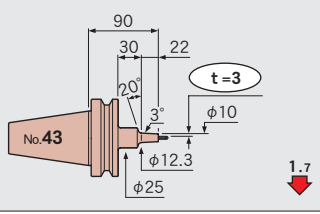

BT50-SLRA4-120-M22

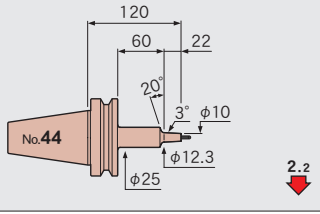

BT50-SLRA4-150-M22

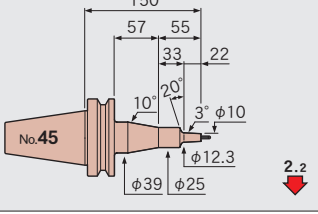

BT50-SLRA4-110-M42

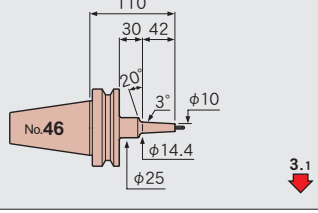

BT50-SLRA4-140-M42

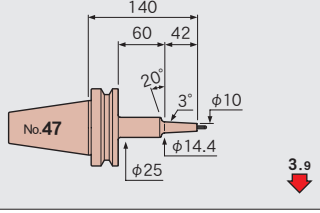

BT50-SLRA4-170-M42

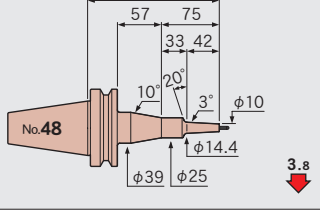

BT50-SLRA4-135-M67

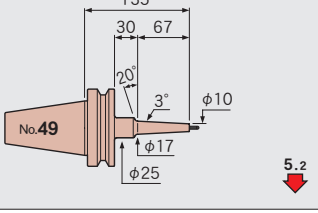

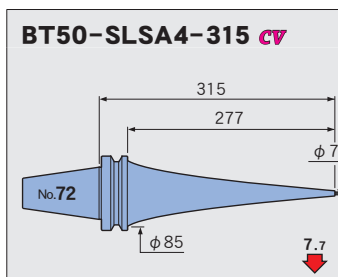
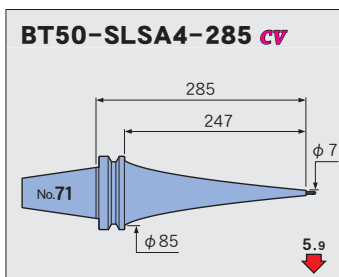
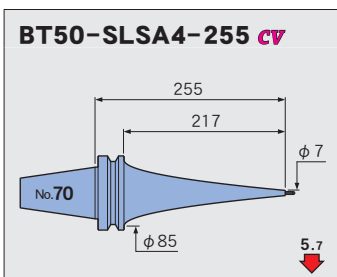
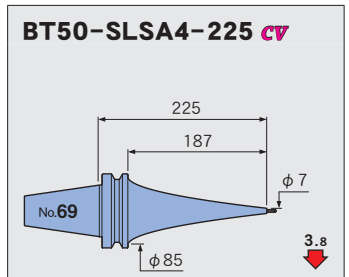
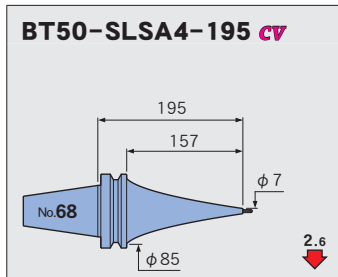
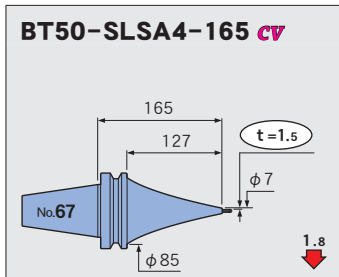
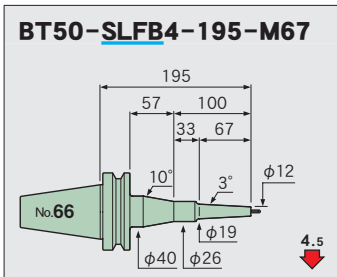
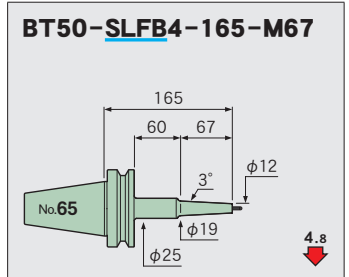
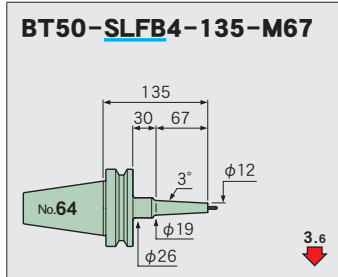
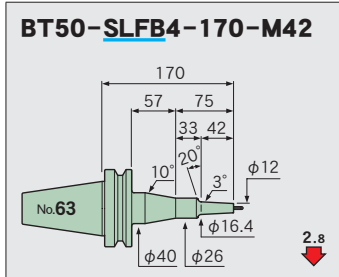
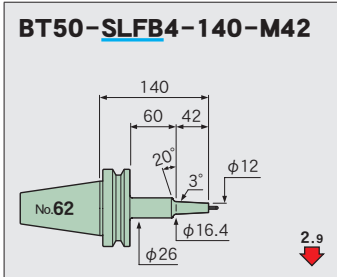
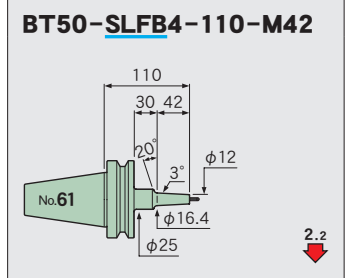
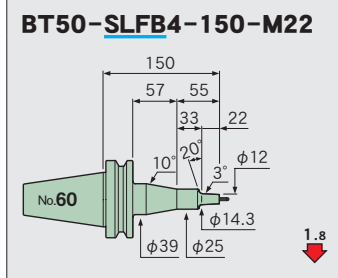
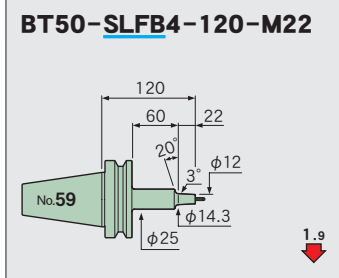
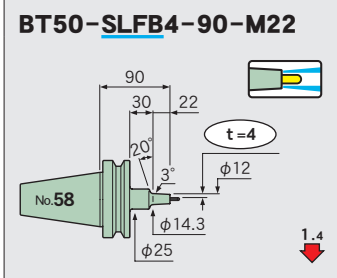
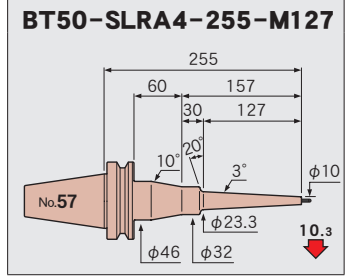
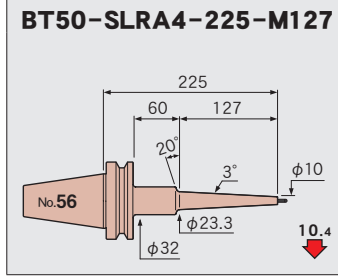
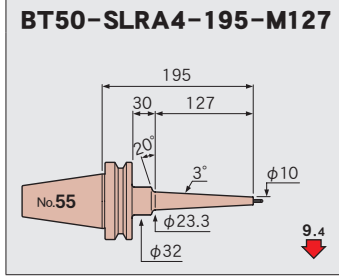
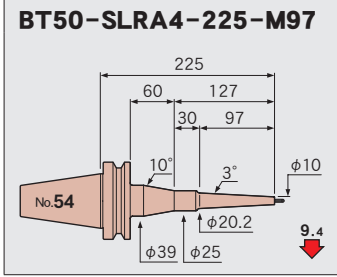
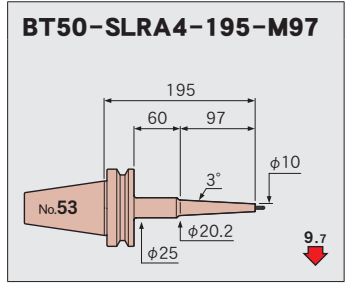
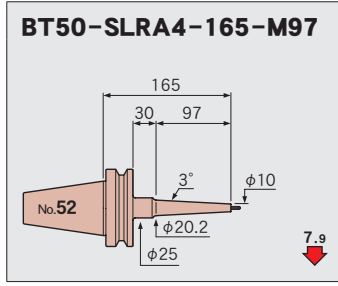
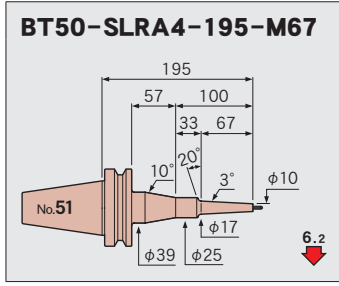
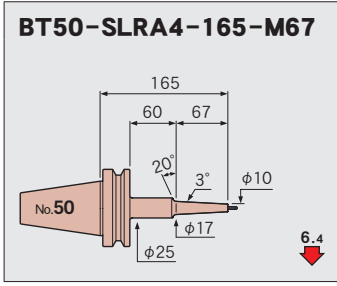

Feature

Shrink-fit Heater

MONO 3°
MONO CURVE

MONO Series

2PIECE type

UNO

HYPER
version

STRAIGHT
arbor

OTHERS

PERIPHERALS

Technical
Information

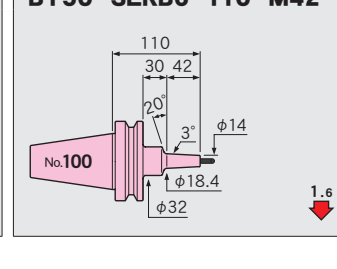
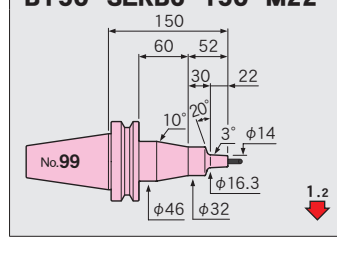
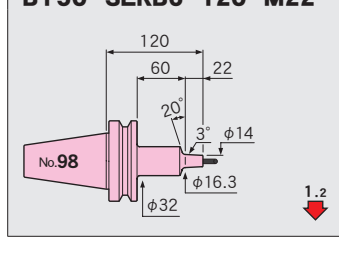
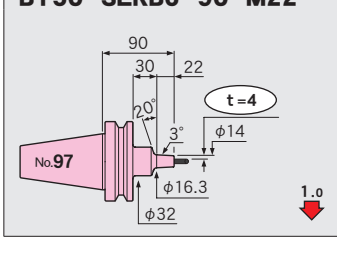
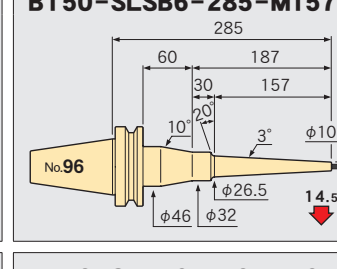
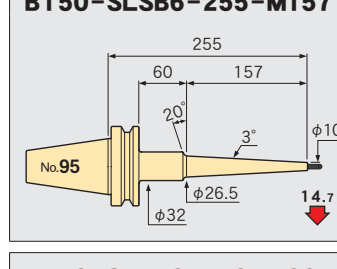
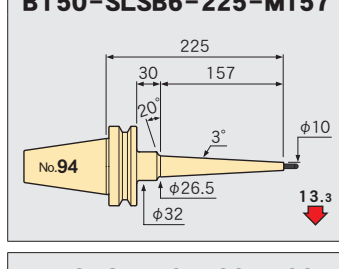
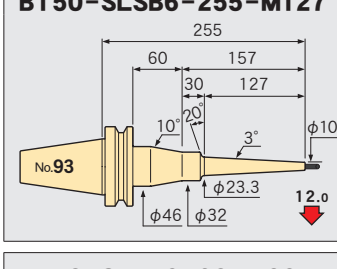
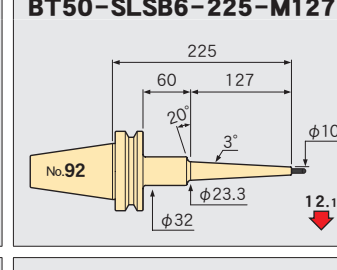
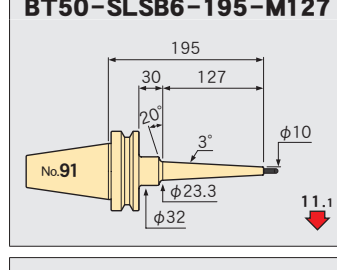
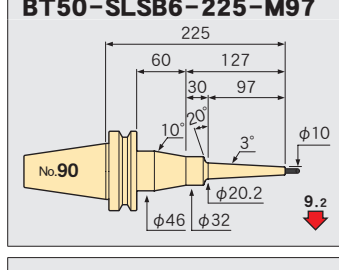
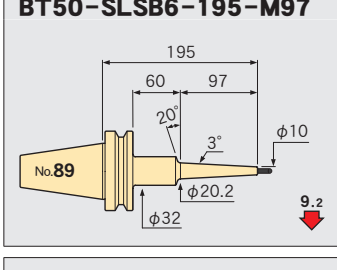
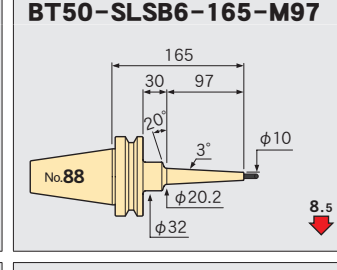
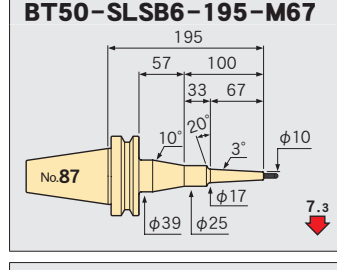
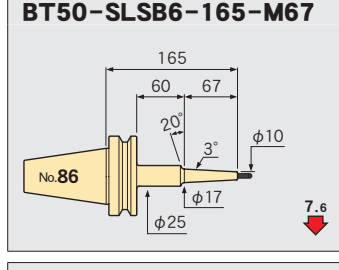
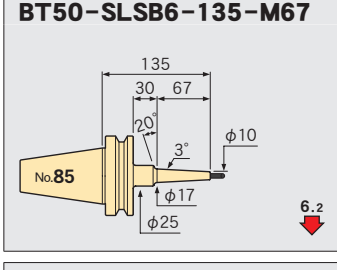
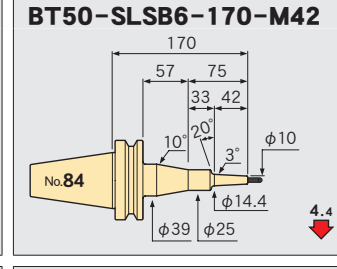
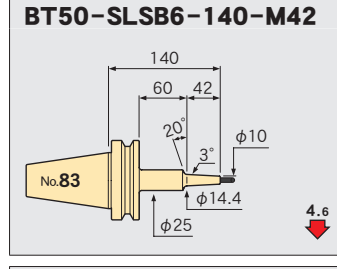
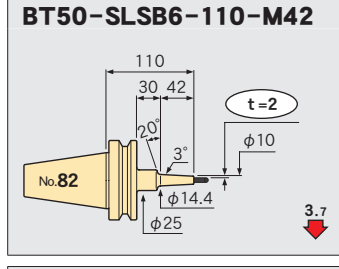
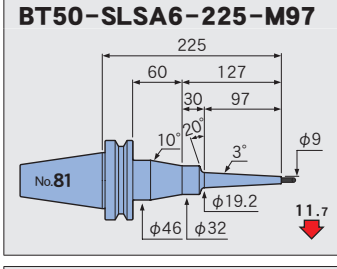
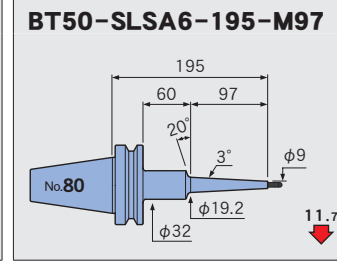
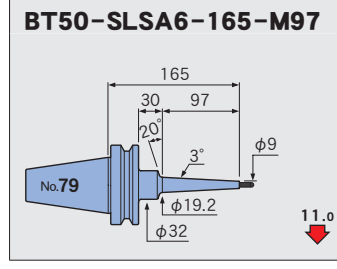
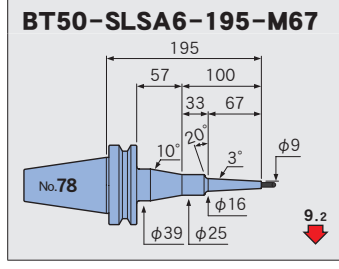
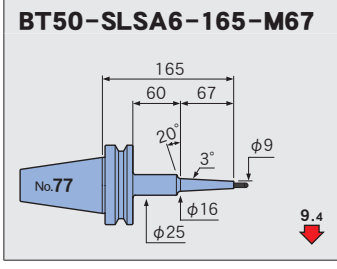
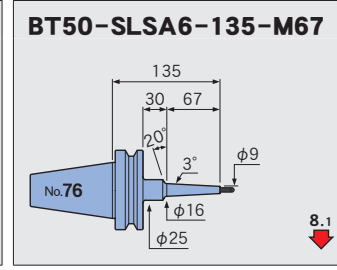
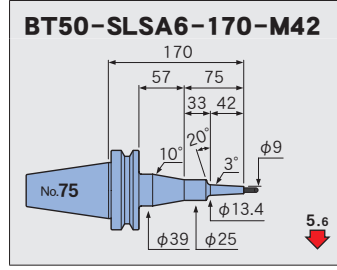
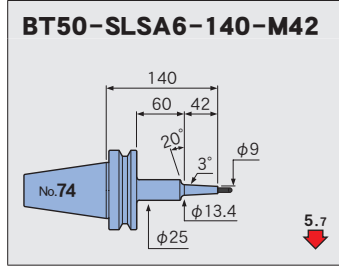
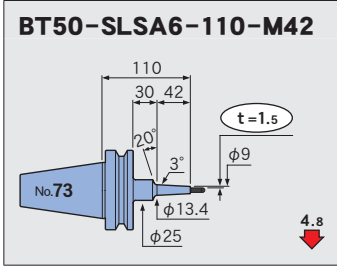

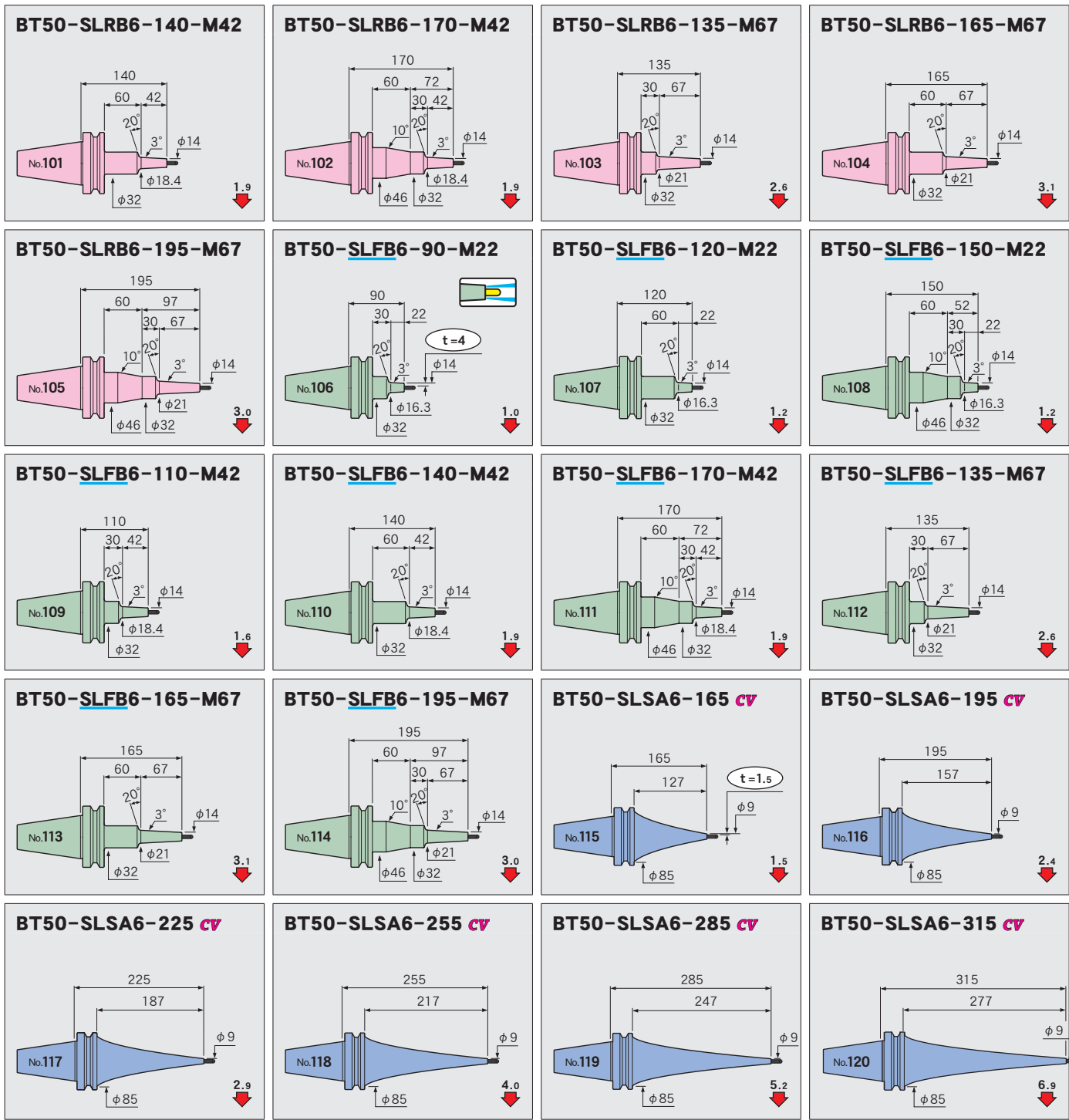

Feature

Shrink-fit Heater

MONO 3°
MONO CURVE

MONO Series

2PIECE type

UNO

HYPER
version

STRAIGHT
arbor

OTHERS

PERIPHERALS

Technical
Information

φ 8

Feature

Shrink-fit Heater

MONO 3° MONO CURVE

MONO Series

2PIECE type

UNO

HYPER version

STRAIGHT anbor

OTHERS

PERIPHERALS

Technical Information

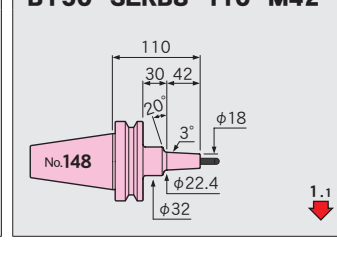
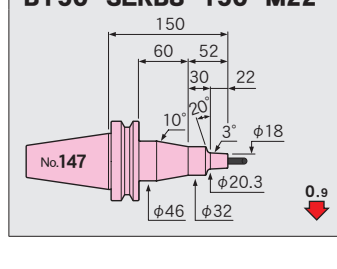
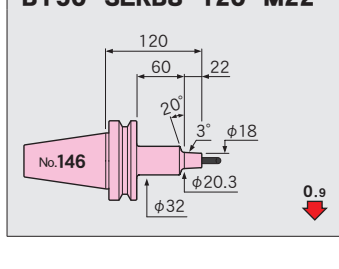
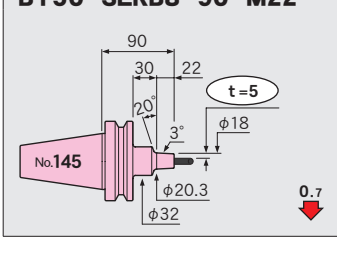
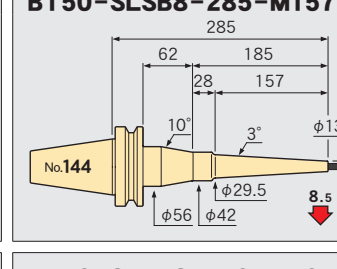
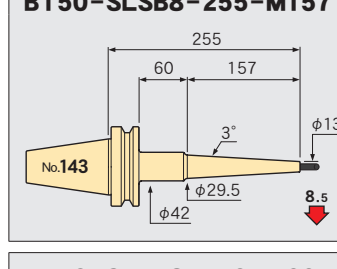
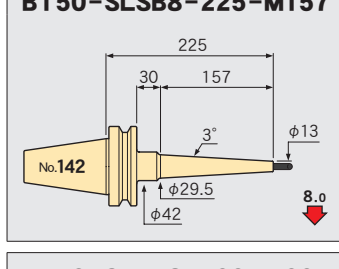
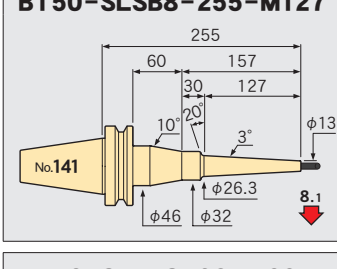
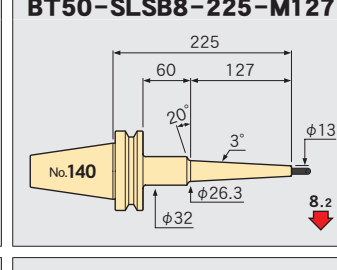
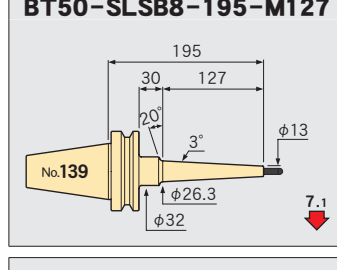
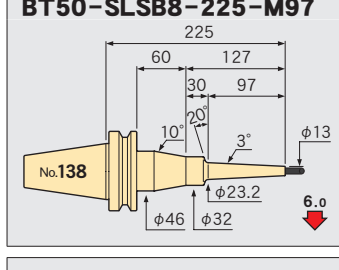
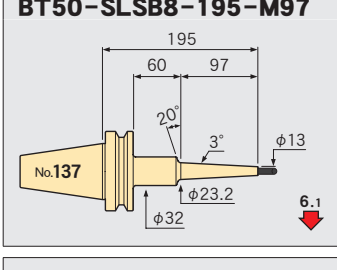
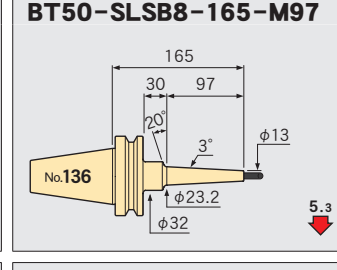
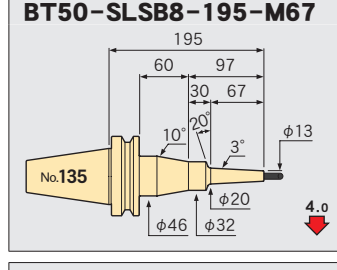
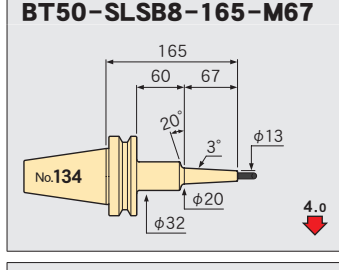
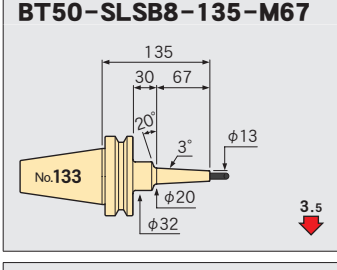
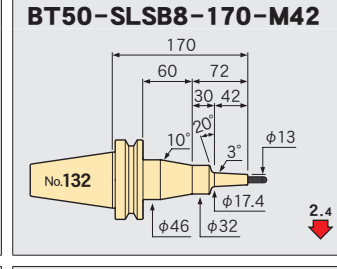
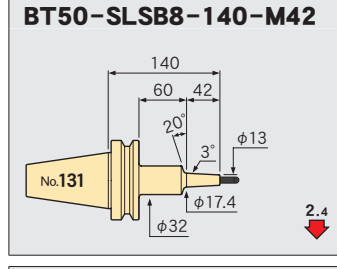
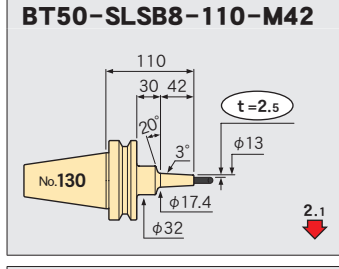
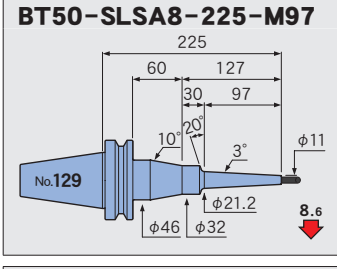
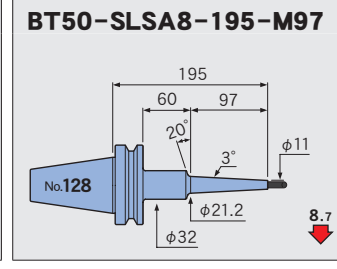
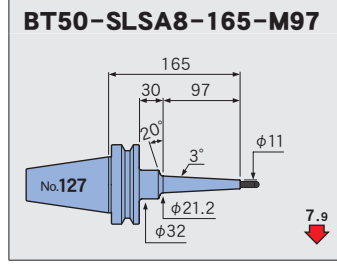
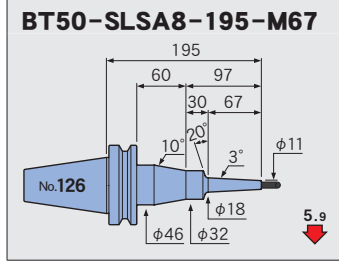
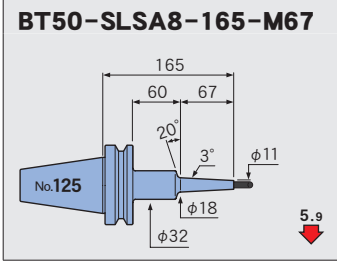
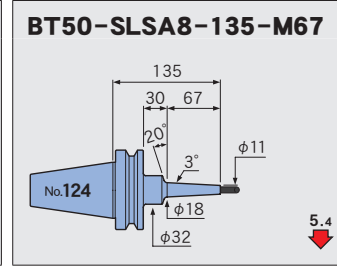
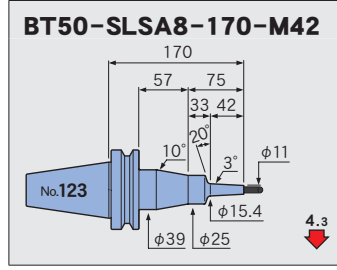
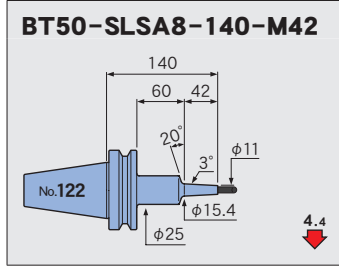
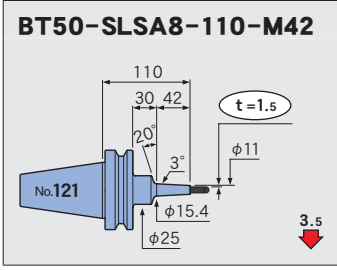

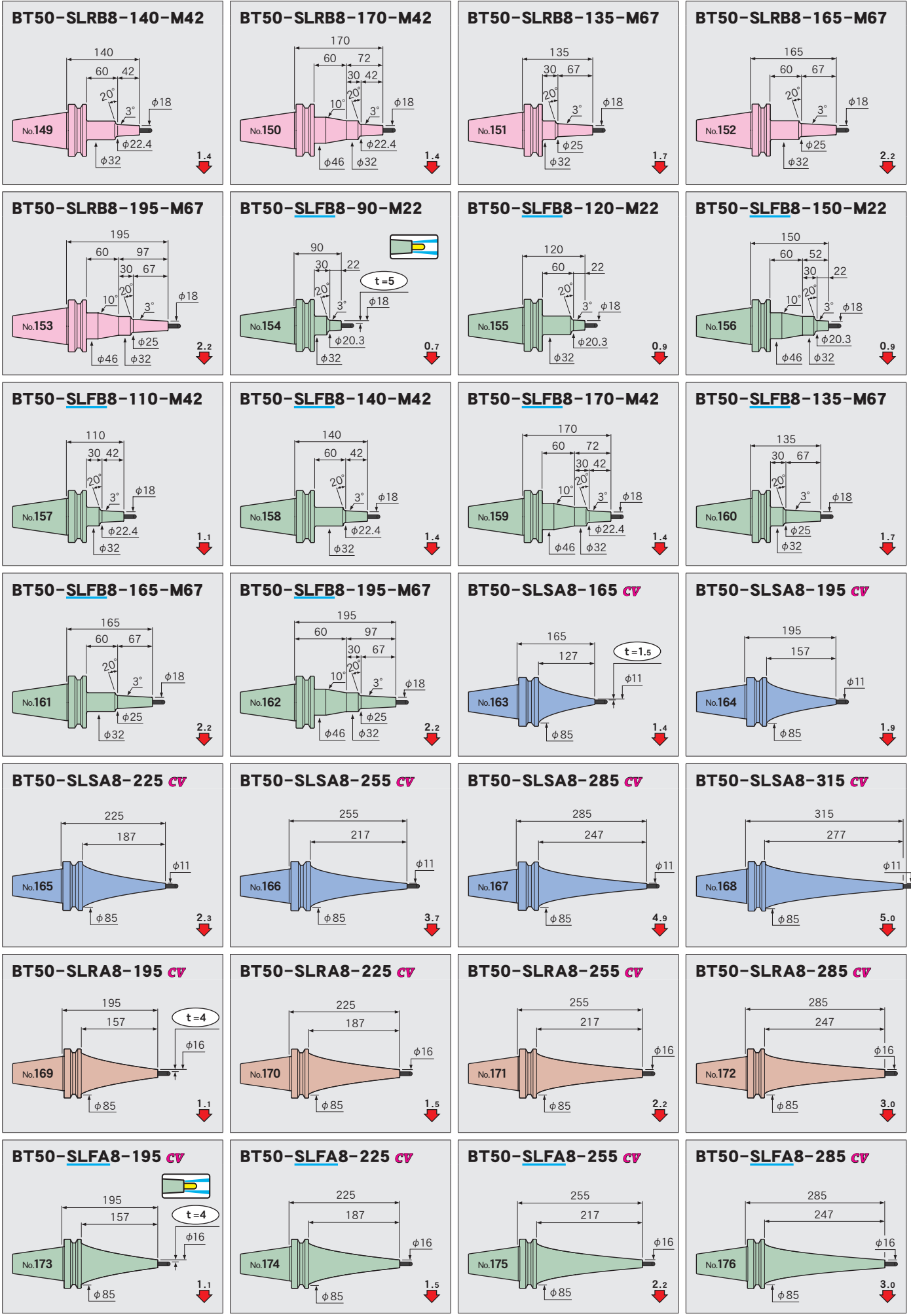

Shrink-fit Heater

MONO 3°
MONO CURVE

MONO Series

2PIECE type

UNO

HYPER
version

STRAIGHT
arbor

OTHERS

PERIPHERALS

Technical
Information

φ10

Feature

Shrink-fit Heater

MONO 3° MONO CURVE

MONO Series

2PIECE type

UNO

HYPER version

STRAIGHT anbor

OTHERS

PERIPHERALS

Technical Information

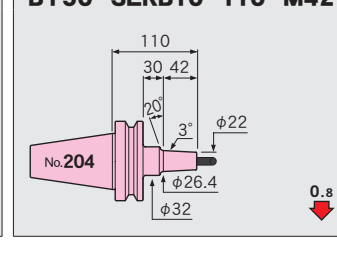
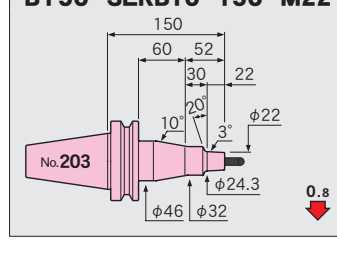
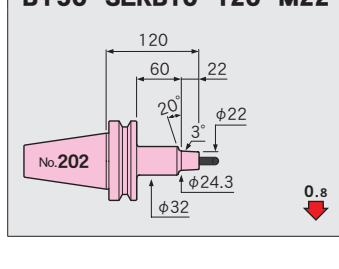
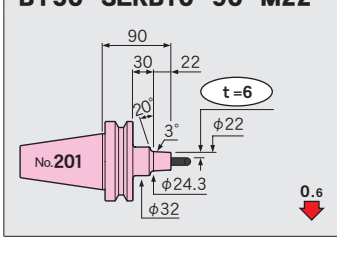
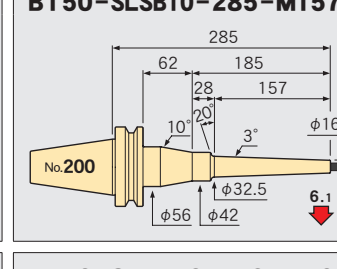
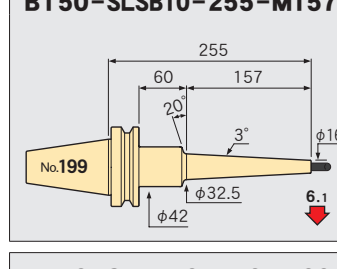
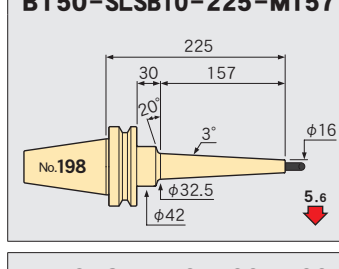
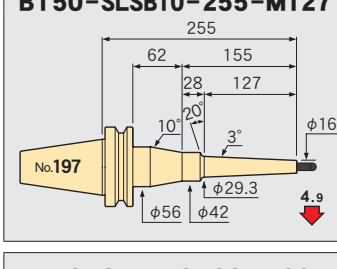
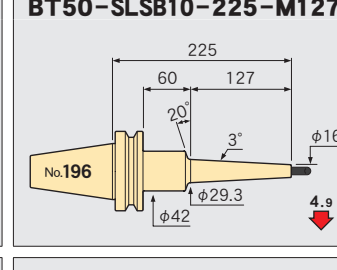
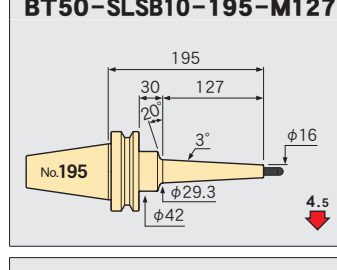
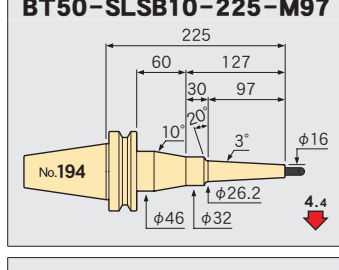
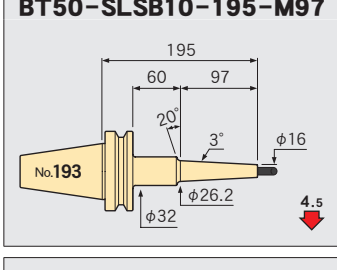
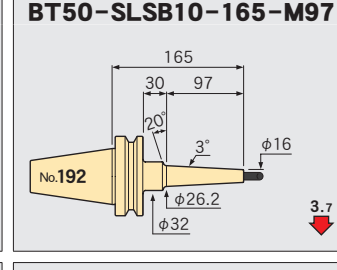
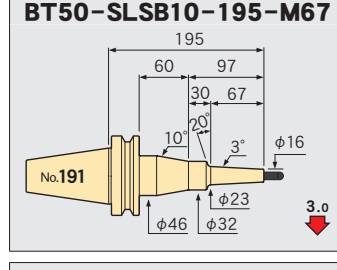
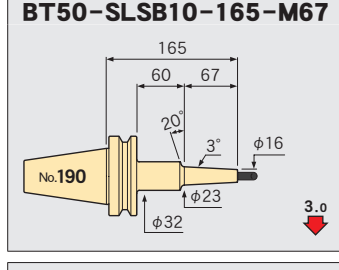
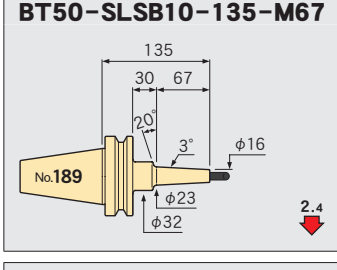
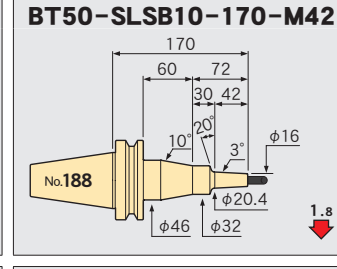
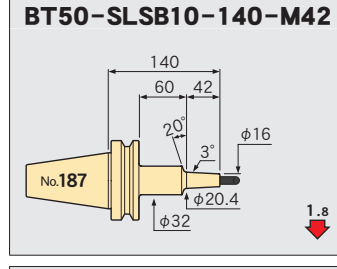
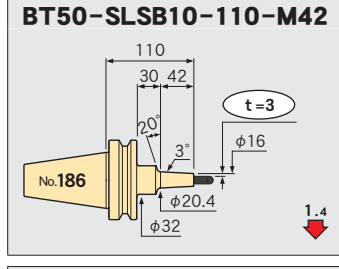
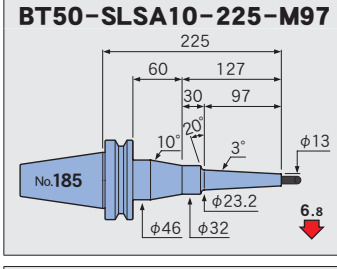
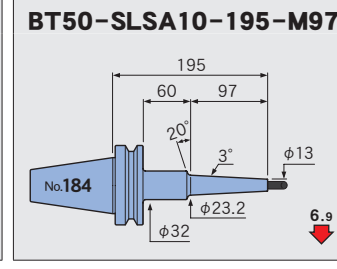
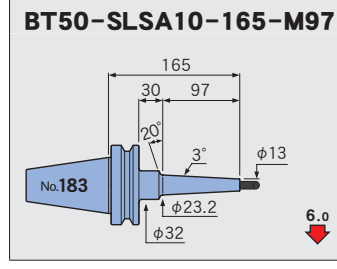
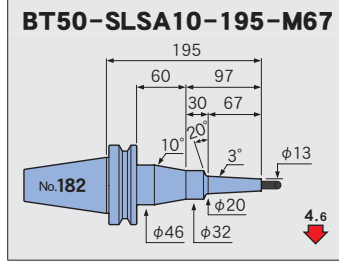
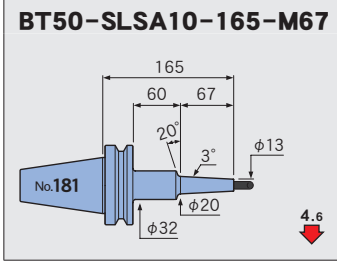
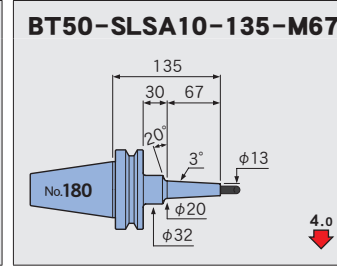
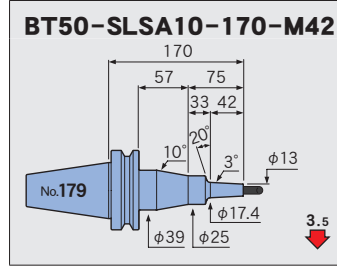
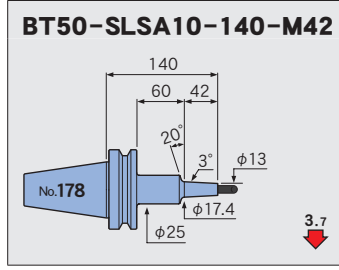
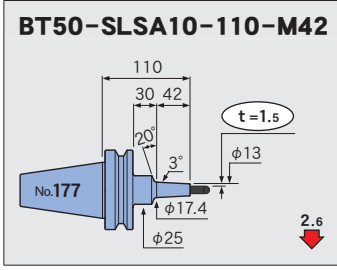

<p>BT50-SLRB10-140-M42</p>	<p>BT50-SLRB10-170-M42</p>	<p>BT50-SLRB10-135-M67</p>	<p>BT50-SLRB10-165-M67</p>
<p>BT50-SLRB10-195-M67</p>	<p>BT50-SLFB10-90-M22</p>	<p>BT50-SLFB10-120-M22</p>	<p>BT50-SLFB10-150-M22</p>
<p>BT50-SLFB10-110-M42</p>	<p>BT50-SLFB10-140-M42</p>	<p>BT50-SLFB10-170-M42</p>	<p>BT50-SLFB10-135-M67</p>
<p>BT50-SLFB10-165-M67</p>	<p>BT50-SLFB10-195-M67</p>	<p>BT50-SLSA10-165 cv</p>	<p>BT50-SLSA10-195 cv</p>
<p>BT50-SLSA10-225 cv</p>	<p>BT50-SLSA10-255 cv</p>	<p>BT50-SLSA10-285 cv</p>	<p>BT50-SLSA10-315 cv</p>
<p>BT50-SLRA10-165 cv</p>	<p>BT50-SLRA10-195 cv</p>	<p>BT50-SLRA10-225 cv</p>	<p>BT50-SLRA10-255 cv</p>
<p>BT50-SLRA10-285 cv</p>	<p>BT50-SLFA10-165 cv</p>	<p>BT50-SLFA10-195 cv</p>	<p>BT50-SLFA10-225 cv</p>

Feature
 Shrink-fit Heater
 MONO 3° MONO CURVE
 MONO Series
 2PIECE type
 UNO
 HYPER version
 STRAIGHT anbor
 OTHERS
 PERIPHERALS
 Technical Information

BT50-SLFA10-255 CV

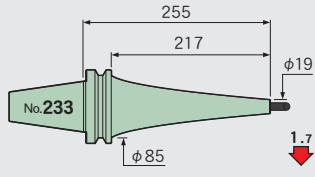

BT50-SLFA10-285 CV

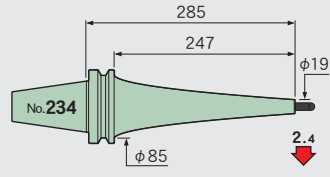

φ12

BT50-SLSA12-110-M42

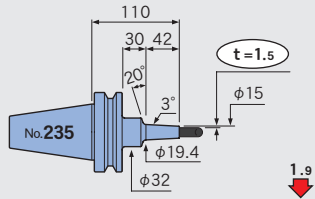

BT50-SLSA12-140-M42

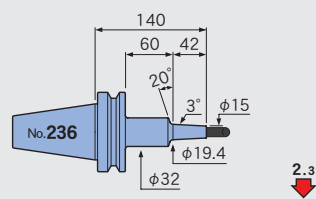

BT50-SLSA12-170-M42

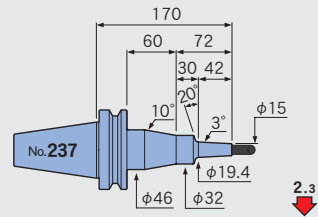

BT50-SLSA12-135-M67

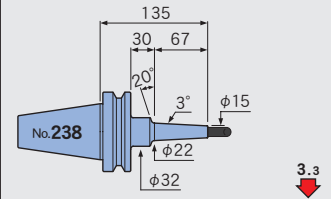

BT50-SLSA12-165-M67

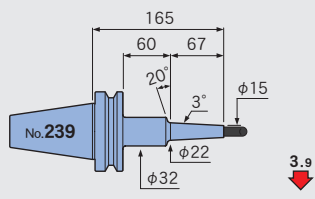

BT50-SLSA12-195-M67

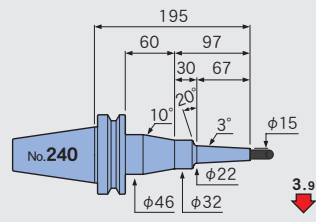

BT50-SLSA12-165-M97

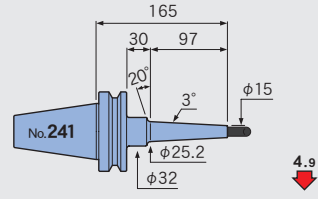

BT50-SLSA12-195-M97

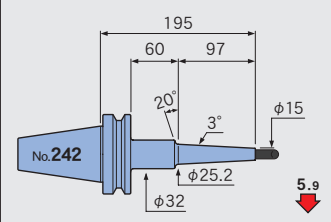

BT50-SLSA12-225-M97

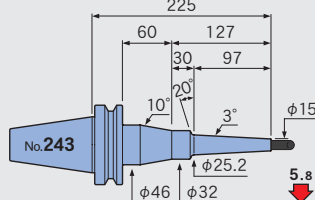

BT50-SLSB12-110-M42

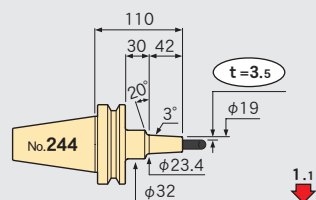

BT50-SLSB12-140-M42

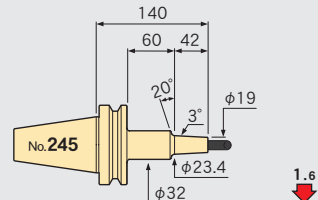

BT50-SLSB12-170-M42

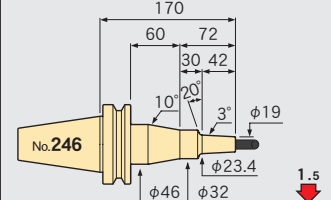

BT50-SLSB12-135-M67

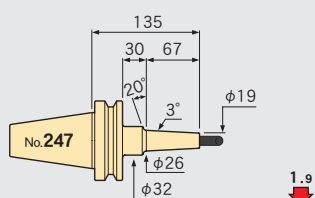

BT50-SLSB12-165-M67

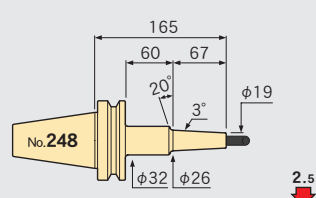

BT50-SLSB12-195-M67

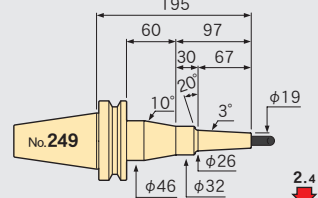

BT50-SLSB12-165-M97

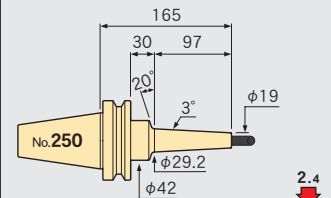

BT50-SLSB12-195-M97

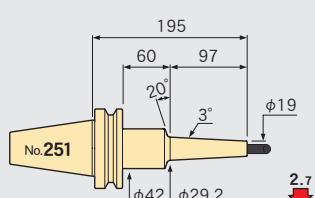

BT50-SLSB12-225-M97

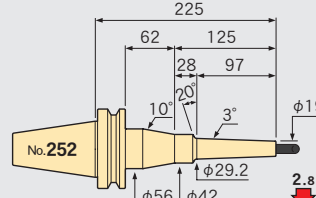

BT50-SLSB12-195-M127

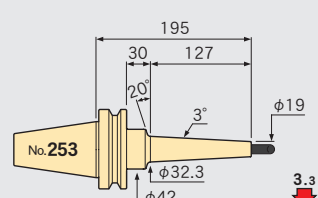

BT50-SLSB12-225-M127

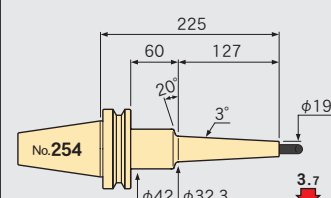

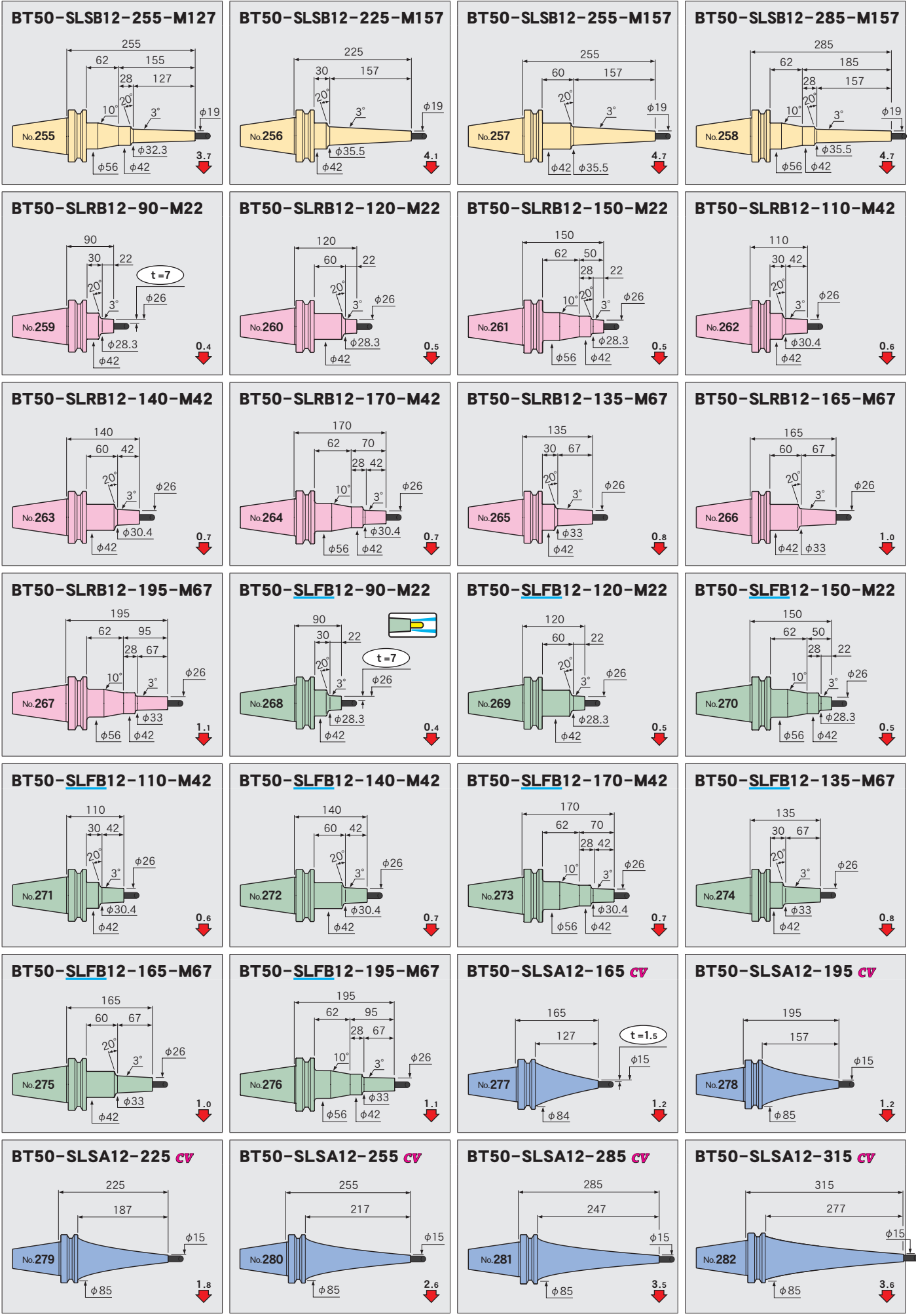

Shrink-fit Heater

MONO 3°
MONO CURVE

2PIECE type

UNO

HYPER
version

STRAIGHT
arbor

OTHERS

PERIPHERALS

Technical
Information

Feature

Shrink-fit Heater

MONO 3°
MONO CURVE

MONO Series

2PIECE type

UNO

HYPER version

STRAIGHT anbor

OTHERS

PERIPHERALS

Technical Information

BT50-SLRA12-165 CV

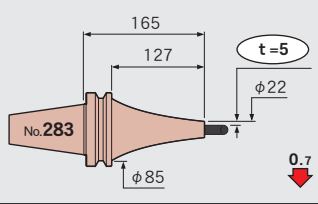

BT50-SLRA12-195 CV

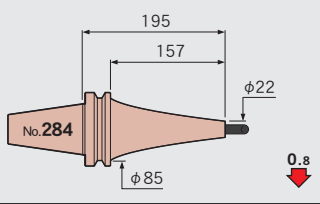

BT50-SLRA12-225 CV

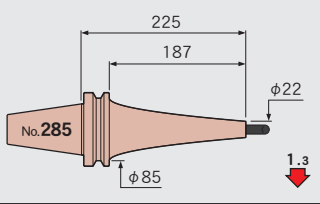

BT50-SLRA12-255 CV

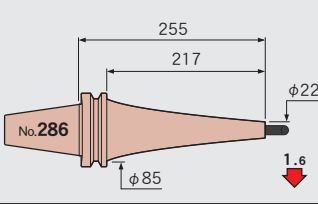

BT50-SLRA12-285 CV

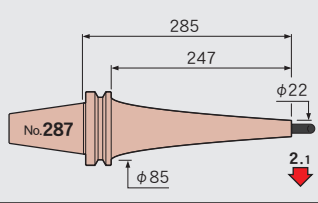

BT50-SLFA12-165 CV

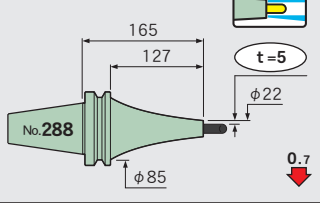

BT50-SLFA12-195 CV

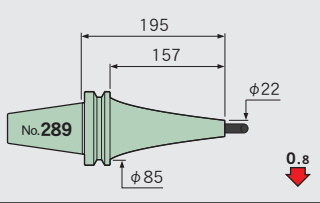

BT50-SLFA12-225 CV

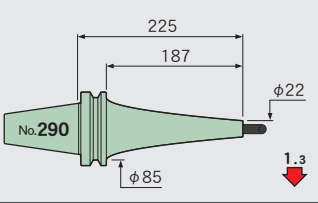

BT50-SLFA12-255 CV

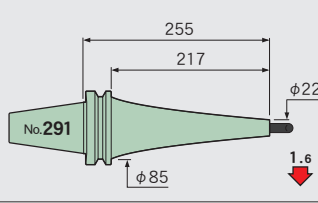

BT50-SLFA12-285 CV

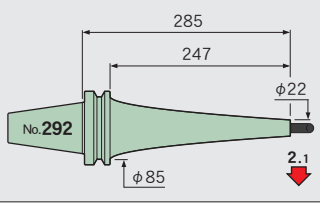

φ16

BT50-SLSB16-110-M42

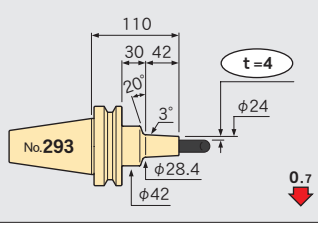

BT50-SLSB16-140-M42

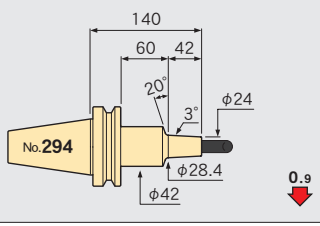

BT50-SLSB16-170-M42

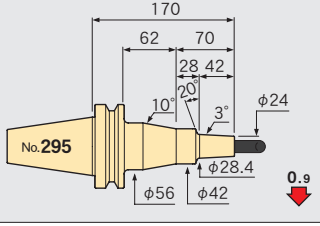

BT50-SLSB16-135-M67

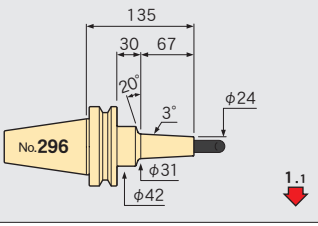

BT50-SLSB16-165-M67

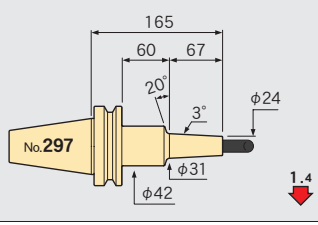

BT50-SLSB16-195-M67

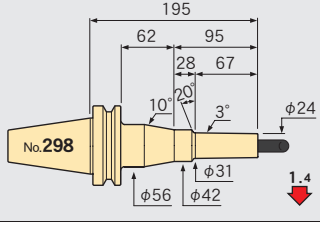

BT50-SLSB16-165-M97

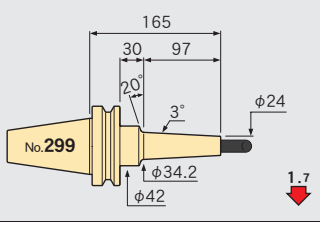

BT50-SLSB16-195-M97

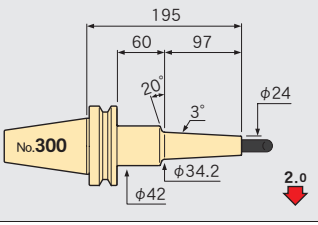

BT50-SLSB16-225-M97

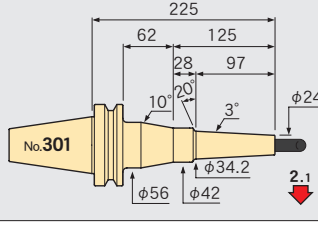

BT50-SLSB16-195-M127

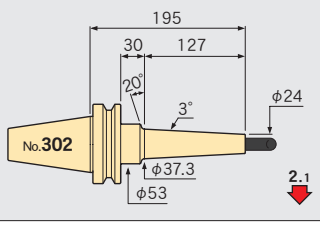

BT50-SLSB16-225-M127

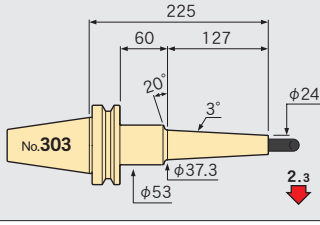

BT50-SLSB16-255-M127

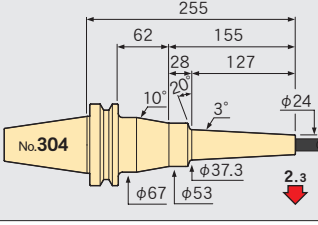

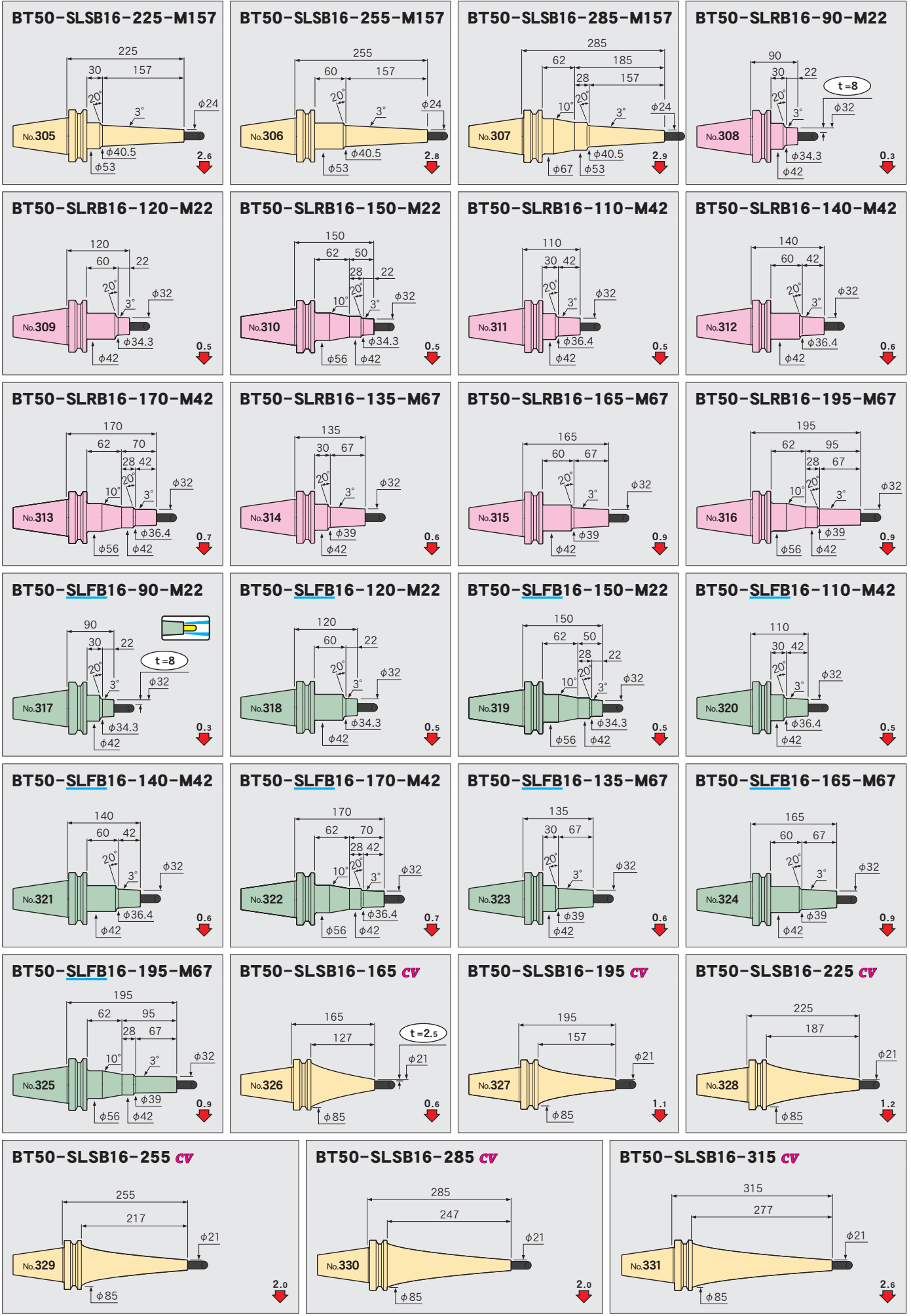

Feature

Shrink-fit Heater

MONO 3°
MONO CURVE

MONO Series

2PIECE type

UNO

HYPER
version

STRAIGHT
airbor

OTHERS

PERIPHERALS

Technical
Information

φ20

Feature
Shrink-fit Heater
MONO 3° MONO CURVE
MONO Series
2PIECE type
UNO
HYPER version
STRAIGHT anbor
OTHERS
PERIPHERALS
Technical Information

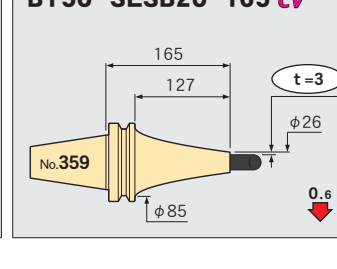
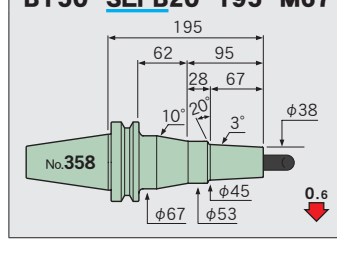
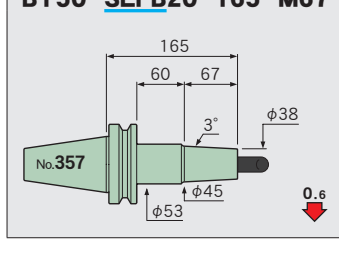
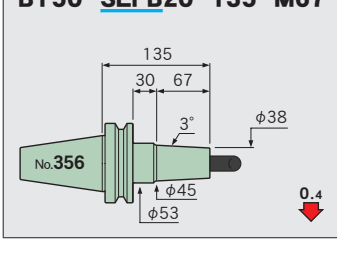
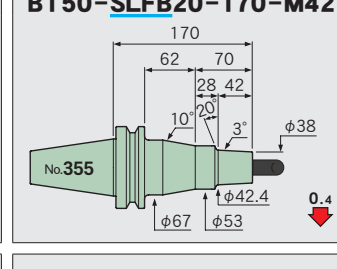
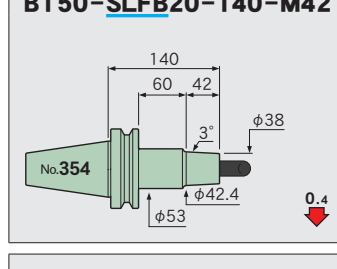
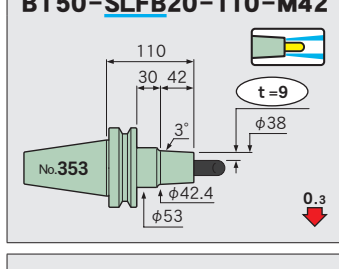
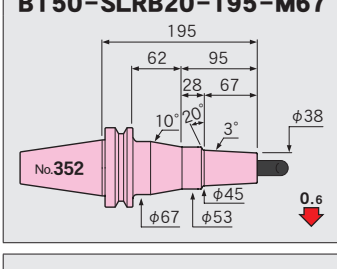
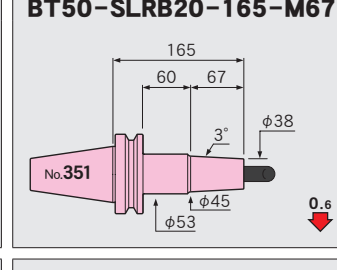
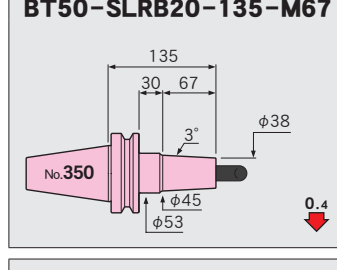
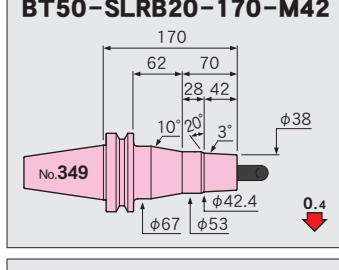
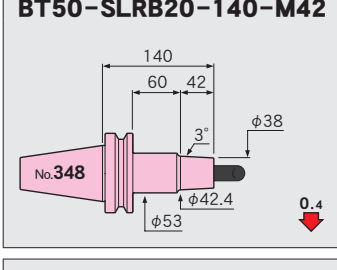
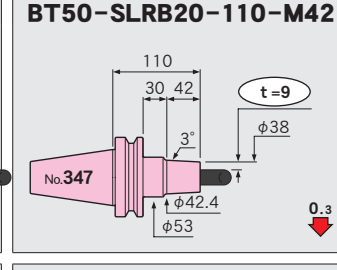
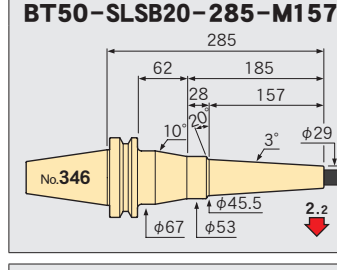
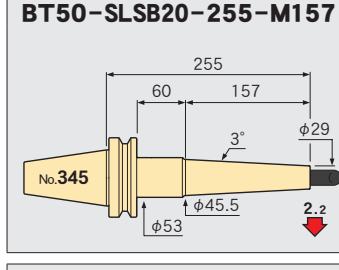
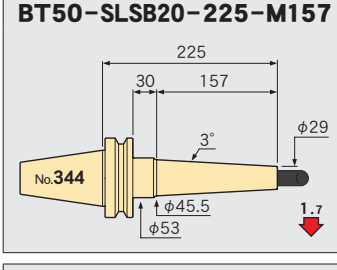
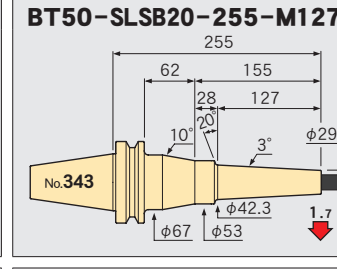
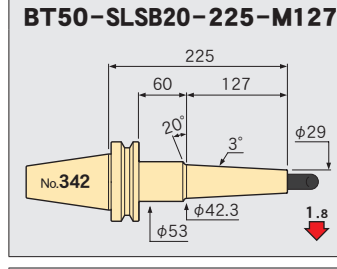
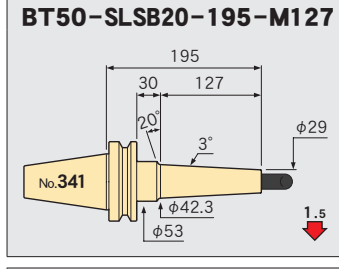
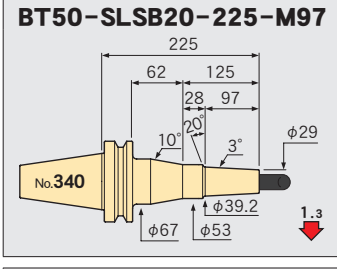
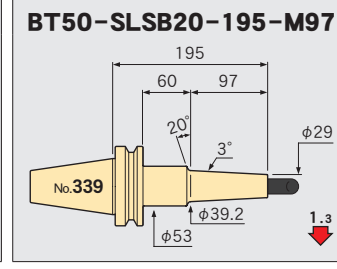
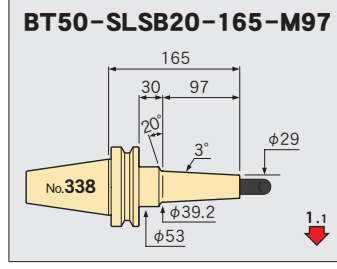
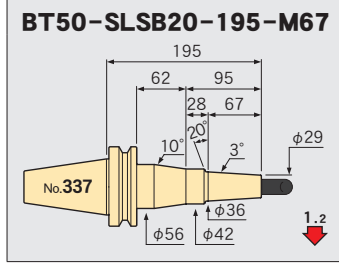
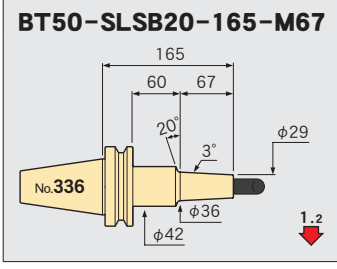
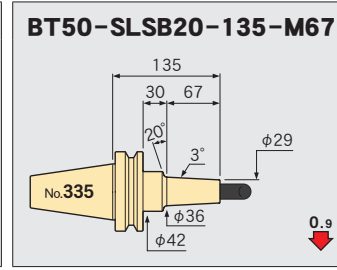
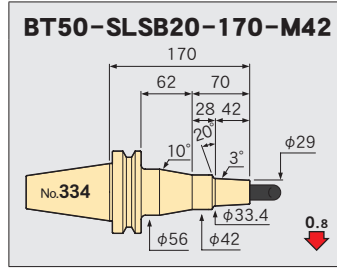
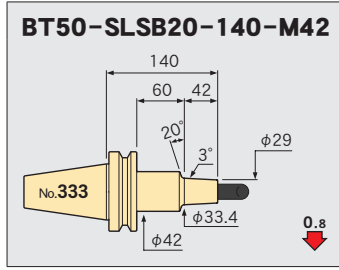
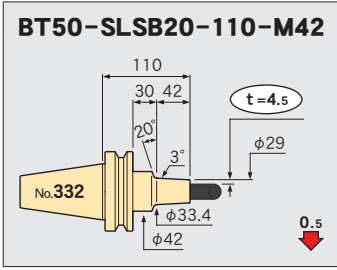

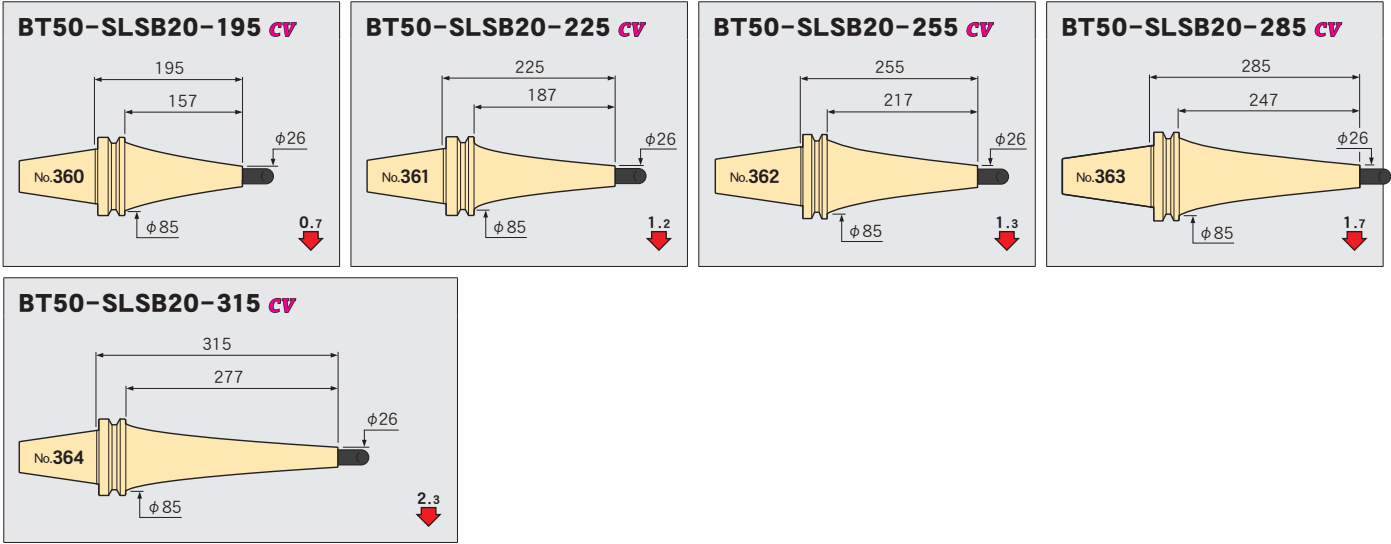

$\phi 25$

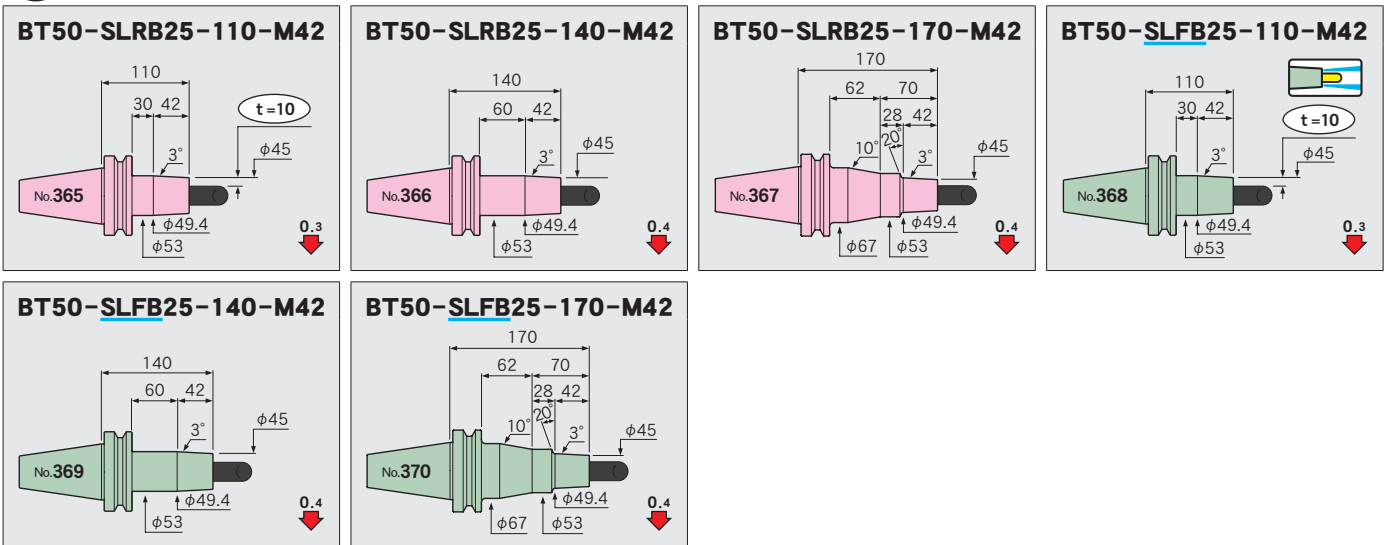

$\phi 32$

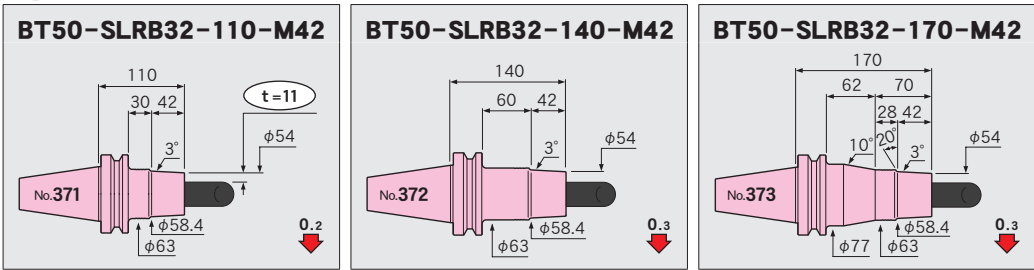

φ70 Nozzle(HRB-03S)
 Required for shrinking the SLRB32.

CODE
HRB-NZL70



HEAT ROBO Baby 3000S

Feature
 Shrink-fit Heater
 MONO 3°
 MONO CURVE
 MONO Series
 2PIECE type
 UNO
 HYPER version
 STRAIGHT arbor
 OTHERS
 PERIPHERALS
 Technical information

A40

MONO 3°

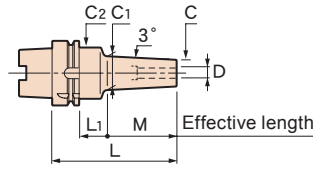
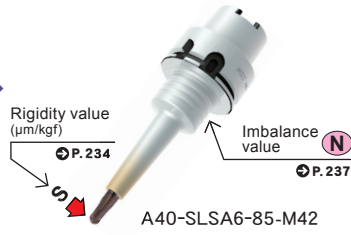

■ **Std.Access.**
 • Coolant duct (fixed type)→P.218

■ **Note**
 • Swing type coolant ducts are available upon request.
 For details, please contact us.

■ **Caution**
 • Setting cutters···Be sure to insert the tool beyond the safety mark.

Compatibility table for HRD-01S

[○] Available [×] Not available

CODE	φD	φC	t	L	M	L1	φC1	φC2	H	h	Kg	N	S	Scale model	
A40-SLSA3- 65-M22	3	6	1.5	65	22	23	8.3	25	9	44	0.3	3	4.5	○	1
				85	42		10.4		64		3.2	9.1	2		
				100		38		78		3.3	9.3	3			
-SLRA3- 65-M22	3	7.5	2.25	65	22	23	9.8	25	9	44	0.3	3	2.7	○	4
				85	42		11.9		64		3.2	5.3	5		
-SLFB3- 65-M22	3	9.5	3.25	65	22	23	11.8	25	9	44	0.3	3	1.2	○	6
				85	42		13.9		64		3.3	3.2	7		
A40-SLSA4- 60	4	7	1.5	60	22	18	9.3	20	12	44	0.2	1.4	3.8	○	8
				65		23		25		0.3	3.1	3.5	9		
				80	42	18	11.4	20	64	0.2	1.4	7.5	10		
				85		23		25		0.3	3.4	7.1	11		
				100		38		78		3.5	7.4	12			
-SLRA4- 65-M22	4	10	3	65	22	23	12.3	25	12	44	0.3	3.1	1.7	○	13
				85	42		14.4		64		3.5	3.1	14		
-SLFB4- 65-M22	4	12	4	65	22	23	14.3	25	12	44	0.3	3.2	1.3	○	15
				85	42		16.4		64		3.5	2.2	16		
A40-SLSA6- 65-M22	6	9	1.5	65	22	23	11.3	25	18	44	0.3	3.2	2.3	○	17
				80	42	18	13.4	20	54	0.2	1.5	5.1	18		
				85		23		25	64	0.3	3.9	4.8	19		
				100		38		78		4	5.1	20			
SLRA6- 65-M22	6	12	3	65	22	23	14.3	25	18	44	0.3	3.2	1.3		21
				85	42		16.4		64		3.9	2.4	22		
-SLFB6- 70-M22	6	14	4	70	22	28	16.3	32	18	48	0.4	4.1	1	○	23
				90	42		18.4		68		4.7	1.6	24		
A40-SLSA8- 65-M22	8	11	1.5	65	22	23	13.3	25	24	44	0.3	3.2	1.6	○	25
				85	42	23	15.4		64		4.3	3.4	26		
				100		38		78		4.4	3.8	27			
-SLRA8- 65-M22	8	14	3	65	22	23	16.3	25	24	44	0.3	3.2	1.1	○	28
				85	42		18.4		64		4.3	2	29		
-SLFB8- 70-M22	8	18	5	70	22	28	20.3	32	24	48	0.4	4.1	0.7	×	30
				90	42		22.4		68		5.2	1.1	31		
A40-SLSA10- 65-M22	10	13	1.5	65	22	23	15.3	25	30	44	0.3	3	1.2	○	32
				85	42		17.4		64		4.6	2.6	33		
				90		28		26		1.9		34			
				100		38		25		4.7	3	35			
-SLRA10- 65	10	16	3	65	22	23	18.3	26	25	44	0.3	1.6	0.9	○	36
								25	30		3	1	37		
				90	42	28	20.4	32	69	0.4	5.4	1.5	38		
-SLFB10- 70-M22	10	22	6	70	22	28	24.3	32	30	48	0.4	3.9	0.6	×	39
				90	42		26.4		68	0.5	5.6	0.9	40		



CODE	φD	φC	t	L	M	L ₁	φC ₁	φC ₂	H	h	Kg	N	S	Scale model
A40-SLSA12- 65-M22	12	15	1.5	65	22	23	17.3	25	30	44	0.3	3.3	1.1	41
- 90-M42				90	42	28	19.4	32		68	0.4	6.1	1.9	42
-SLRA12- 65-M22	12	20	4	65	22	23	22.3	25	30	44	0.3	3.3	0.8	43
-SLFB12- 70-M22	12	26	7	70	22	28	28.3	32	30	48	0.4	4.2	0.6	44
A40-SLRA16- 65-M22	16	26	5	65	22	23	28.3	33.5	32	43	0.4	2	0.5	45
A40-SLRA20- 70-M50	20	32	6	70	50	-	33.5	-	38	48	0.4	2.4	0.6	46



■ Cleaning tool for a spindle taper hole, STAR DUST

CODE
CLT-A40-G2
P. 226

MAKINO
N2-5XA

S=1:4

φ 3

<p>A40-SLSA3-65-M22</p> <p>4.5</p>	<p>A40-SLSA3-85-M42</p> <p>9.1</p>	<p>A40-SLSA3-100-M42</p> <p>9.3</p>
<p>A40-SLRA3-65-M22</p> <p>2.7</p>	<p>A40-SLRA3-85-M42</p> <p>5.3</p>	<p>A40-SLFB3-65-M22</p> <p>1.2</p>
		<p>A40-SLFB3-85-M42</p> <p>3.2</p>

φ 4

<p>A40-SLSA4-60</p> <p>3.8</p>	<p>A40-SLSA4-65-M22</p> <p>3.5</p>	<p>A40-SLSA4-80</p> <p>7.5</p>	<p>A40-SLSA4-85-M42</p> <p>7.1</p>
<p>A40-SLSA4-100-M42</p> <p>7.4</p>	<p>A40-SLRA4-65-M22</p> <p>1.7</p>	<p>A40-SLRA4-85-M42</p> <p>3.1</p>	<p>A40-SLFB4-65-M22</p> <p>1.3</p>
<p>A40-SLFB4-85-M42</p> <p>2.2</p>			

φ6

A40-SLSA6-65-M22

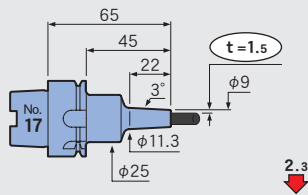

A40-SLSA6-80

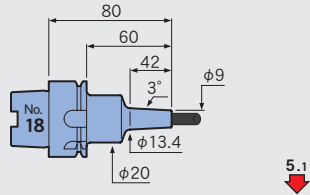

A40-SLSA6-85-M42

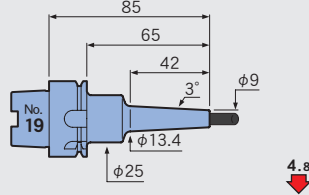

A40-SLSA6-100-M42

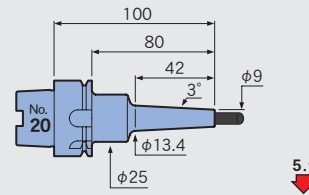

A40-SLRA6-65-M22

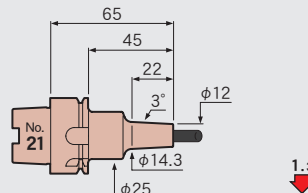

A40-SLRA6-85-M42

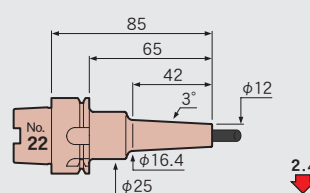

A40-SLFB6-70-M22

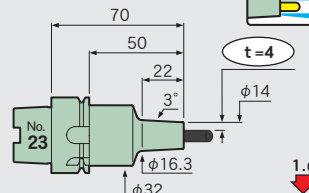

A40-SLFB6-90-M42

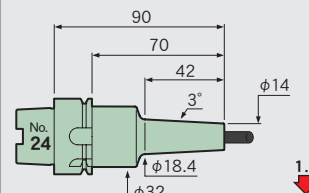

φ8

A40-SLSA8-65-M22

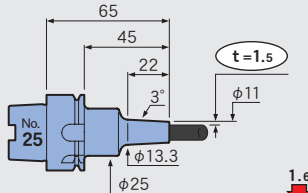

A40-SLSA8-85-M42

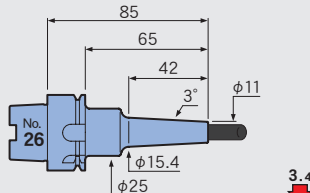

A40-SLSA8-100-M42

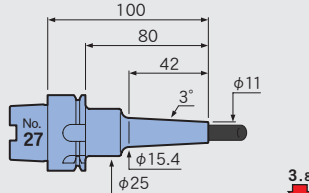

A40-SLRA8-65-M22

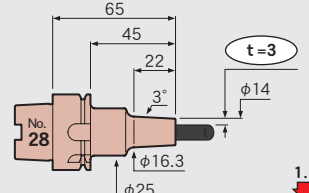

A40-SLRA8-85-M42

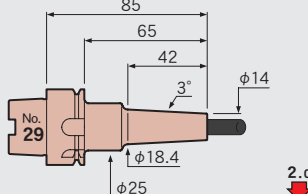

A40-SLFB8-70-M22

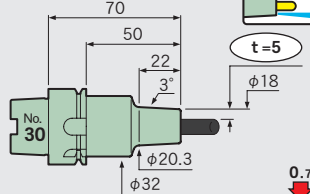

A40-SLFB8-90-M42

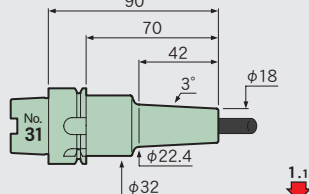

φ10

A40-SLSA10-65-M22

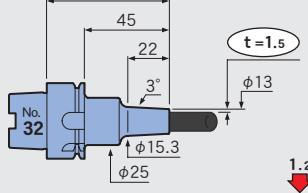

A40-SLSA10-85-M42

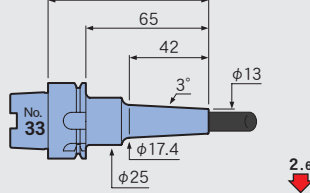

A40-SLSA10-90

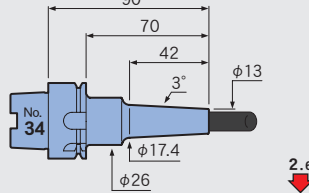

A40-SLSA10-100-M42

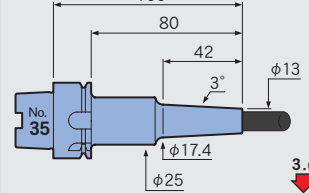

A40-SLRA10-65

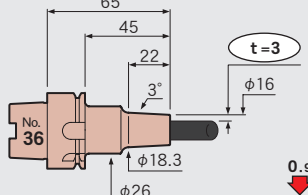

A40-SLRA10-65-M22

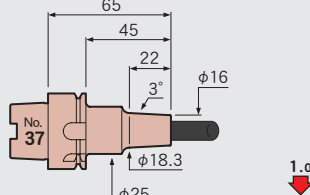

A40-SLRA10-90-M42

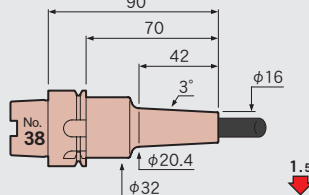

A40-SLFB10-70-M22

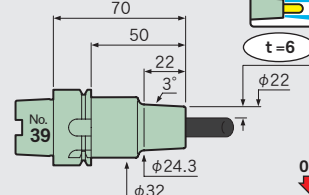

Feature
 Shrink-fit Heater
 MONO 3° MONO CURVE
 MONO Series
 2PIECE type
 UNO
 HYPER version
 STRAIGHT anbor
 OTHERS
 PERIPHERALS
 Technical Information

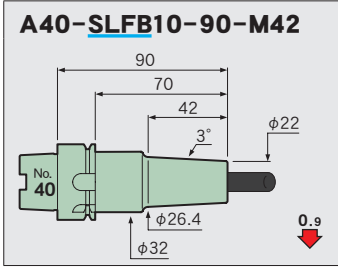

φ12

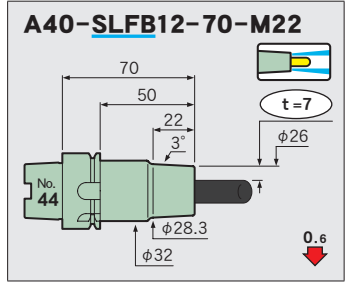
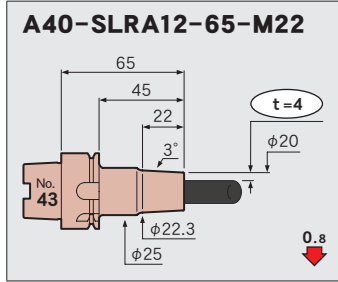
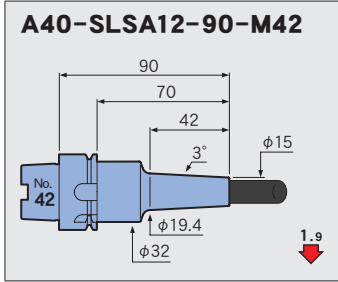
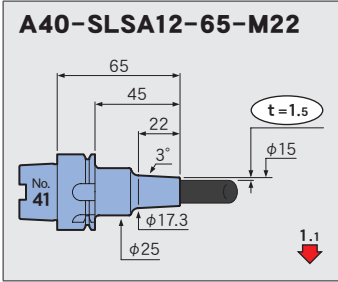

φ16

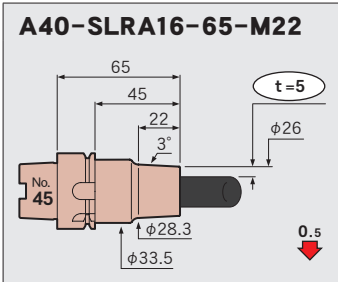

φ20

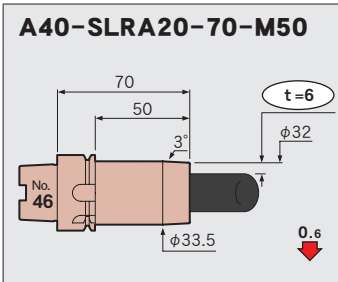

Feature
Shrink-fit Heater

MONO 3°
MONO CURVE

MONO Series

2PIECE type

UNO

HYPER
version

STRAIGHT
arbor

OTHERS

PERIPHERALS

Technical
Information

A50

MONO 3°

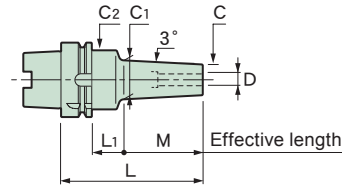

Std. Access.
• Coolant duct (fixed type)→P.218

Note
• Swing type coolant ducts are available upon request. For details, please contact us.

Caution
• Setting cutters---Be sure to insert the tool beyond the safety mark.
• The undercut area of the A50M is different from the standards. Please be careful to check for interference with the ATC arm.

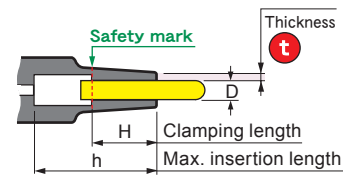

NEW

MONO CURVE CV

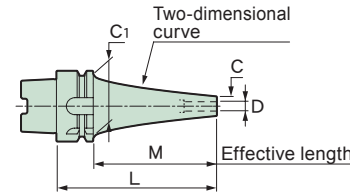

Compatibility table for HRD-01S
[○] Available [×] Not available

CV : Curve Thickness

CODE	Fig	φD	φC	t	L	M	L1	φC1	φC2	H	h	Kg	N	S	Scale model					
A50-SLSA 3- 95-M42	1	3	6	1.5	95	42	27	10.4	25	9	71	0.5	5.8	9.1	○	1				
-125-M42					125		57				101					0.6	6.5	9.8	2	
-SLRA 3- 75-M22	1	3	7.5	2.25	75	22	27	9.8	25	9	51	0.5	6.2	2.8	○	3				
- 95-M42					95						42					11.9	71	6.6	5.3	4
-125-M42					125	57	101	0.6	7.3	6	5									
A50-SLSA 4- 95-M42					1	4	7	1.5	95	42	27	11.4	25	12		71	0.5	7	7.2	○
-125-M42	125	57	101	0.6					7.7		7.9				7					
-SLRA 4- 75-M22	1	4	10	3	75	22	27	12.3	25	12	51	0.5	6.3	1.7	○	8				
- 95-M42					95						42					14.4	71	7	3.1	9
-125-M42					125	57	101	0.6	7.7	3.8	10									
-SLSA 4- 90 CV					2	4	7	1.5	90	64	-	42	-	12		66	0.6	4.8	1.8	○
-120 CV	120	94	96	5					4.2						12					
-150 CV	150	124	126	0.7					5.8						6	13				
-180 CV	180	154	156	0.7					5.9						12	14				
-SLRA 4-120 CV	2	4	10	3					120						94	-				
-150 CV					150	124	126	0.7	5.8	4.1	16									
A50-SLSA 6- 95-M42	1	6	9	1.5	95	42	27	13.4	25	18	71	0.5	7.3	4.8	○	17				
-125-M42					125		57				101					0.6	8	5.6	18	
-SLRB 6- 75-M22	1	6	14	4	75	22	27	16.3	32	18	50	0.5	7.2	1	○	19				
- 95-M42					95						42					18.4	70	0.6	8.9	1.6
-125-M42					125	57	100	0.7	10.2	1.9	21									
-SLSA 6- 90 CV					2	6	9	1.5	90	64	-	42	-	18		65	0.5	4.7	1.6	○
-120 CV	120	94	95	0.6					5.1						3.5	23				
-150 CV	150	124	126	0.7					5.8						5.4	24				
-180 CV	180	154	156	0.8					6.6						7.6	25				
-SLRA 6-120 CV	2	6	13	3.5					120						94	-				
-150 CV					150	124	126	0.8	6.4	2.7	27									
A50-SLSA 8- 95-M42	1	8	11	1.5	95	42	27	15.4	25	24	71	0.5	9.3	3.4	○	28				
-125-M42					125		57				101					0.6	11.8	4.4	29	
-SLRB 8- 75-M22	1	8	18	5	75	22	27	20.3	32	24	50	0.6	7.9	0.7	×	30				
- 95-M42					95						42					22.4	70	10.5	1.1	31
-125-M42					125	57	100	0.8	11.8	1.5	32									
-125-M42																				

CODE	Fig	φD	φC	t	L	M	L ₁	φC ₁	φC ₂	H	h	Kg	N	S	Scale model	
A50-SLSA 8- 90 CV	2	8	11	1.5	90	64	-	42	-	24	66	0.6	4.9	1.4	○	33
-120 CV					120	94					96	0.7	5.7	2.2		34
-150 CV					150	124					126		5.9	4.9		35
-180 CV					180	154					156	0.8	6.7	7.1		36
-SLRA 8-120 CV	2	8	16	4	120	94	-	42	-	24	96	0.8	6.2	1.3	○	37
-150 CV					150	124					126		6.5	2.7		38
A50-SLSA10- 95-M42	1	10	13	1.5	95	42	27	17.4	25	30	71	0.5	10.7	2.6	○	39
-125-M42					125		57			101	0.6	12.1	3.7	40		
-SLRB10- 75-M22	1	10	22	6	75	22	27	24.3	32	30	50	0.6	8.3	0.6	×	41
- 95-M42					95	42		26.4		70		11.9	0.9	42		
-125-M42					125		57			100	0.8	13.3	1.3	43		
A50-SLSA10- 90 CV	2	10	13	1.5	90	64	-	42	-	30	66	0.6	4.9	1.3	○	44
-120 CV					120	94					96	0.7	5.7	2.1		45
-150 CV					150	124					126	0.8	6.5	3.4		46
-180 CV					180	154					156		6.8	6.9		47
A50-SLRA10-150 CV	2	10	19	4.5	150	124	-	42	-	30	126	0.9	6.9	2.2	○	48
A50-SLRB12- 75-M22	1	12	26	7	75	22	27	28.3	42	30	52	0.7	6.2	0.4	×	49
- 95-M42					95	42		30.4		72	0.8	6.3	0.6	50		
-125-M42					125		57			98	1	22.9	0.8	51		
A50-SLRB16- 75-M22	1	16	32	8	75	22	27	34.3	42	32	52	0.7	6.3	0.4	○	52
-105-M22					105		57			78	1	19	0.5	53		
A50M-SLRB20- 75-M22*	1	20	38	9	75	22	27	40.3	49	40	51	0.8	6.4	0.3	○	54
-105-M22*					105		57			76	1.2	15.1	0.4	55		

*When shrinking the SLRB20 with HEAT ROBO DENJI 5000(HRD-02SH), the standard heating coil cannot be used. Please use the heating coil No.4.

Cleaning tool for a spindle taper hole, STAR DUST

CODE
CLT-A50-G2

☎ P.226



HORKOS MAKINO J SUGINO

NJ 50
J3 / L2
SC Dual



S=1:5

φ3

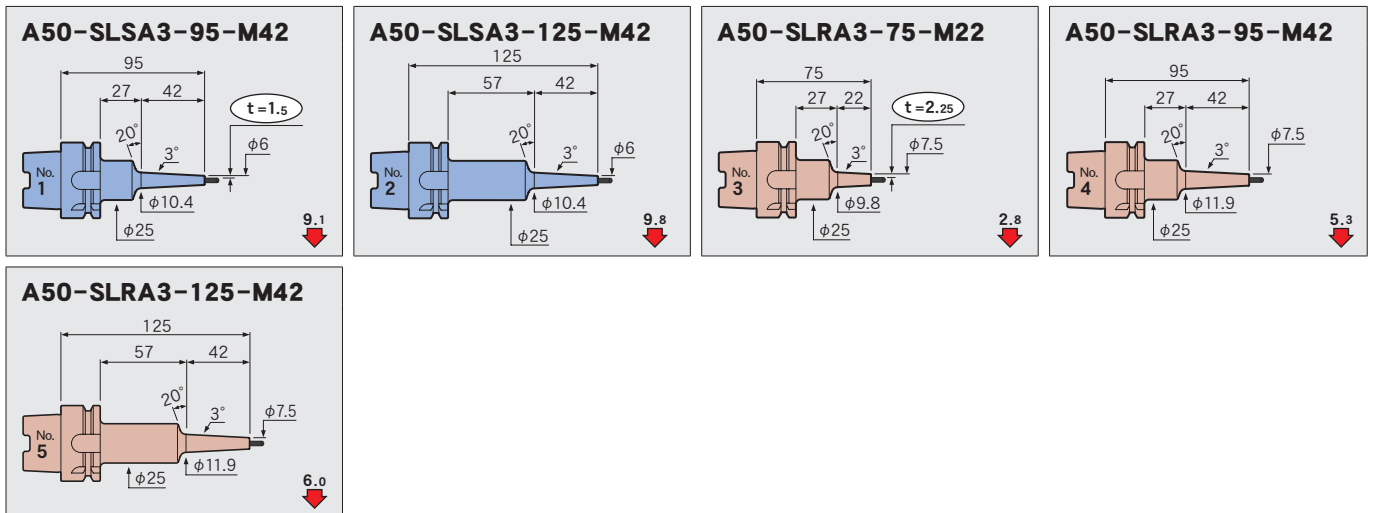

φ4

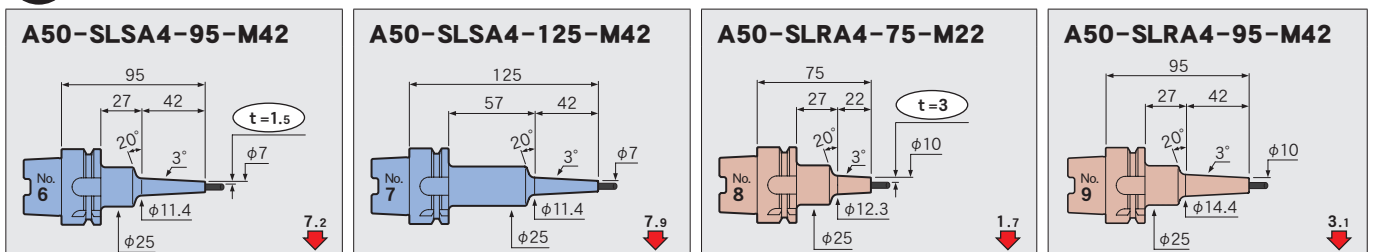

Feature
Shrink-fit Heater
MONO 3° MONO CURVE
MONO Series
2PIECE type
UNO
HYPER version
STRAIGHT anbor
OTHERS
PERIPHERALS
Technical Information

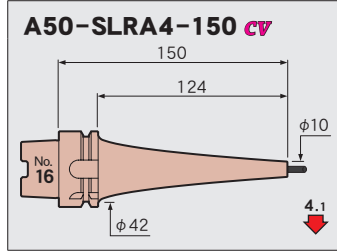
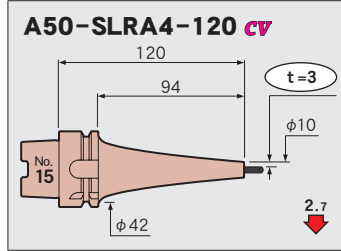
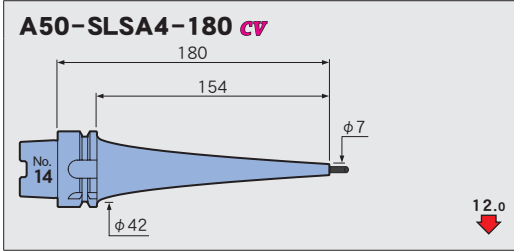
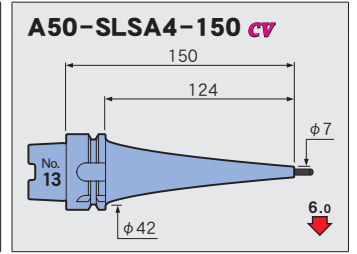
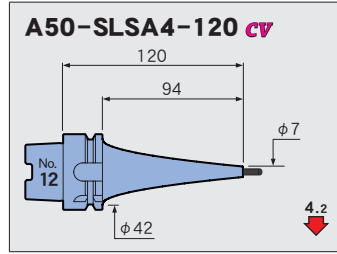
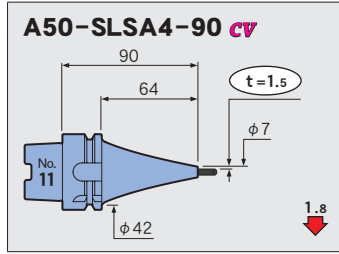
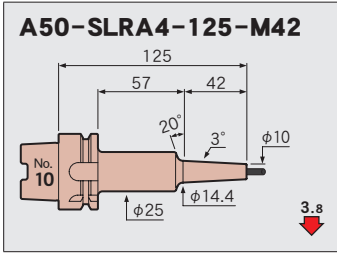

φ6

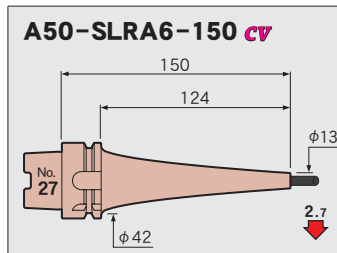
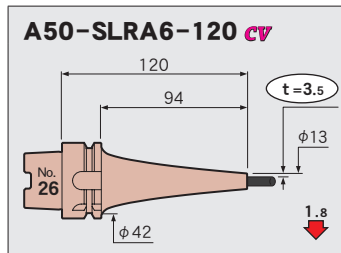
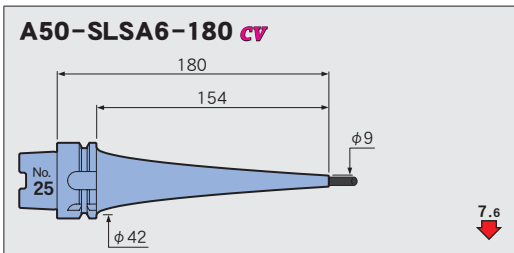
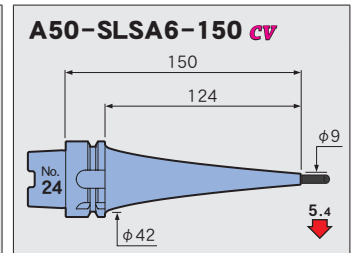
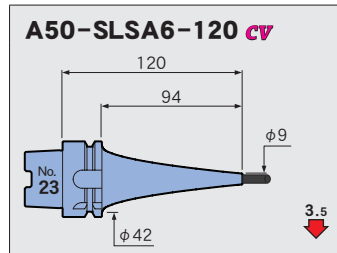
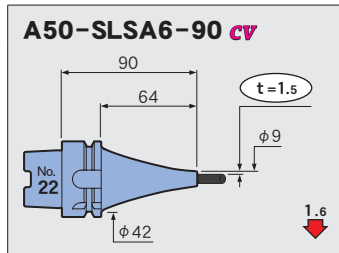
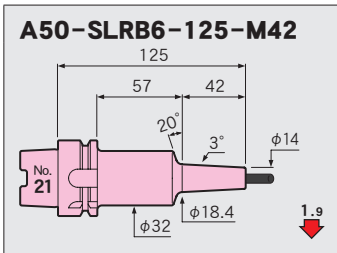
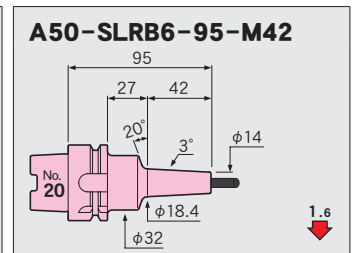
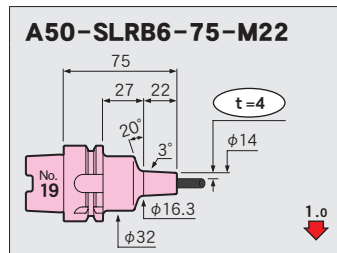
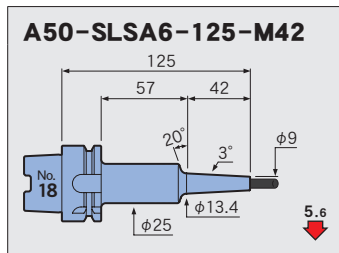
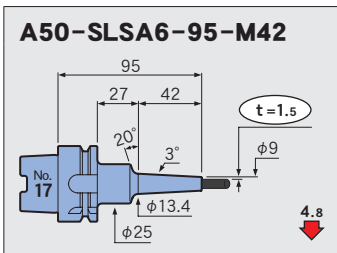

φ8

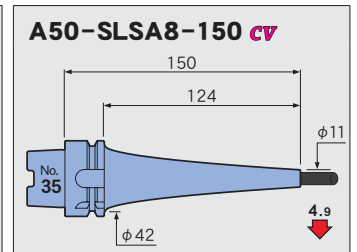
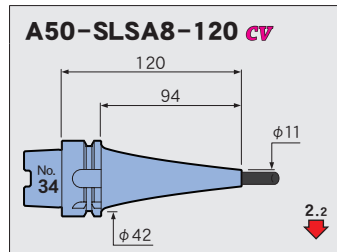
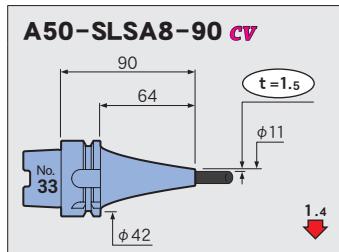
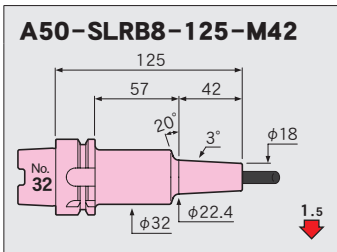
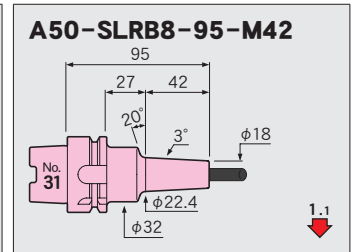
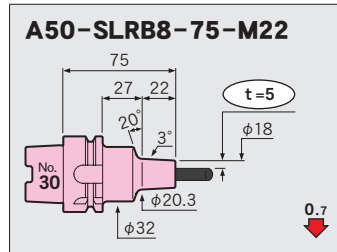
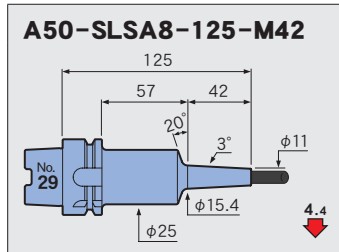
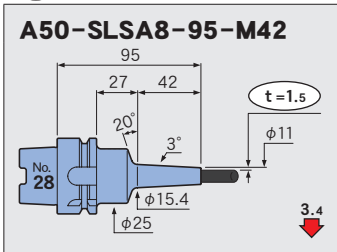

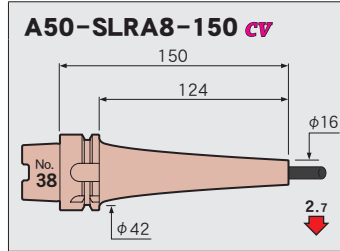
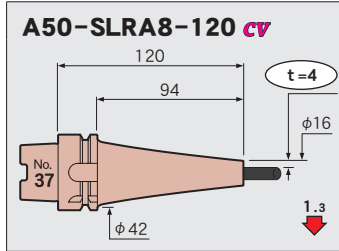
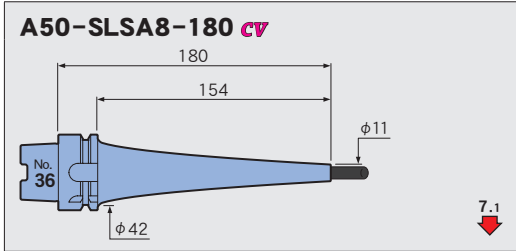

φ10

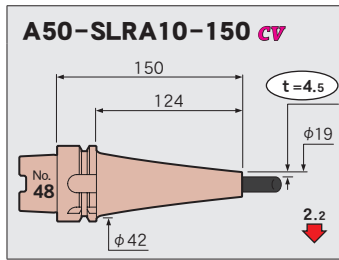
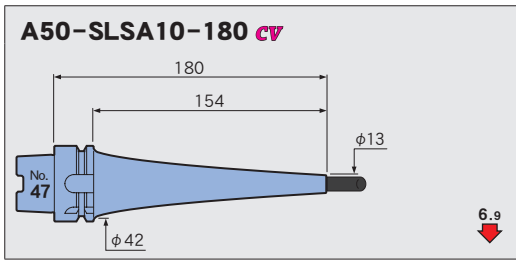
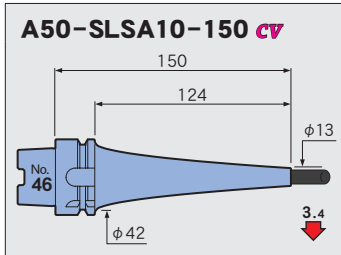
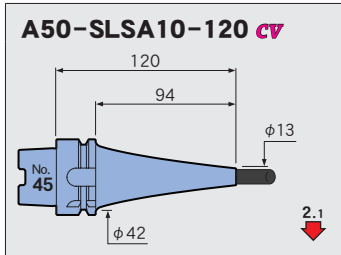
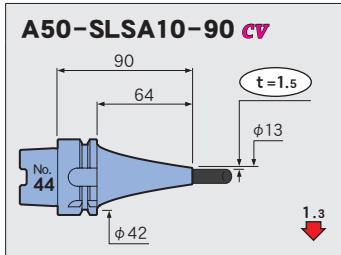
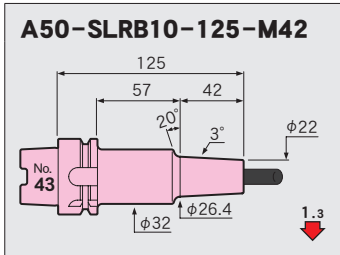
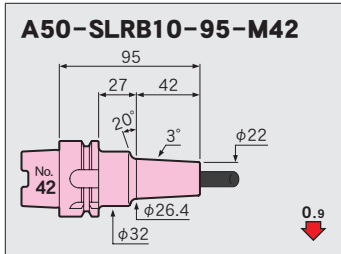
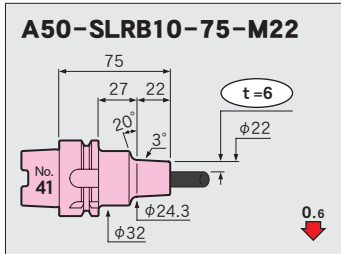
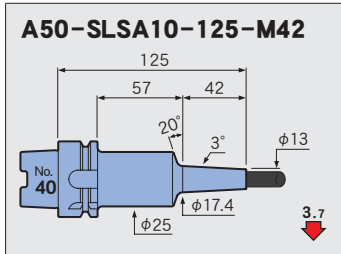
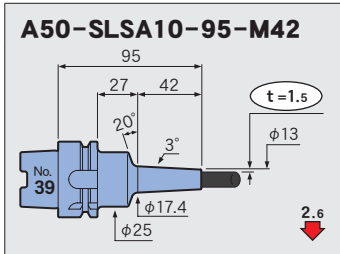

φ12

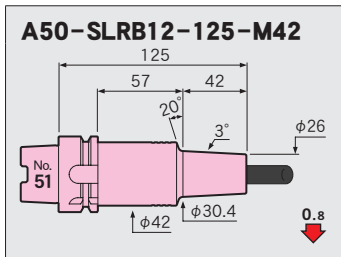
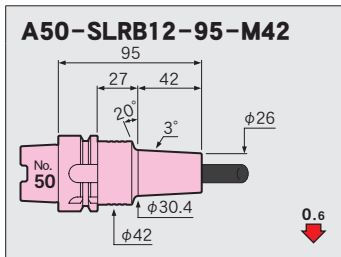
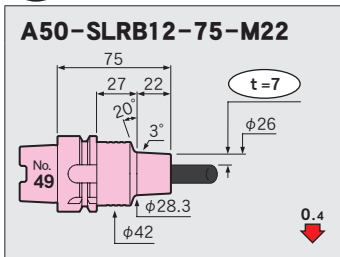

φ16

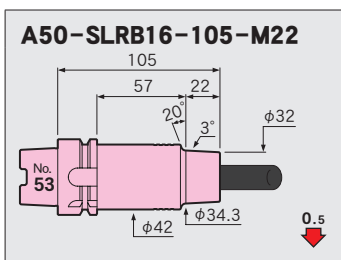
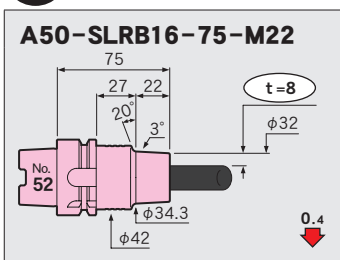

φ20

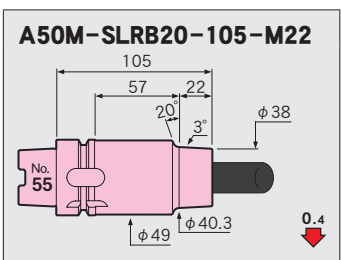
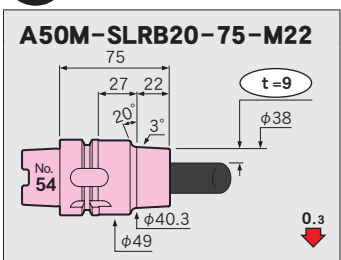

A63

MONO 3°

Rigidity value (μm/kgf)
P.234

Imbalance value
P.237



A63-SLSA6-150-M97

Fig. 1

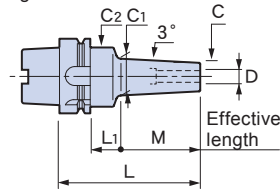
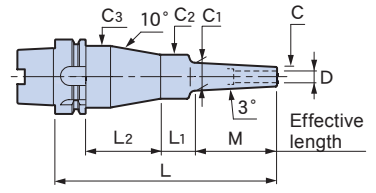

Fig. 2



MONO CURVE

CV

Rigidity value (μm/kgf)
P.234

Imbalance value
P.237



A63-SLSA8-150 cv

Fig. 3

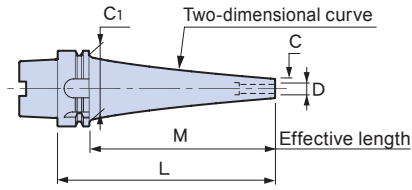

Std. Access.

- Coolant duct (fixed type) →P.218

Note

- Swing type coolant ducts are available upon request. →P.218

Caution

- Setting cutters...Be sure to insert the tool beyond the safety mark.

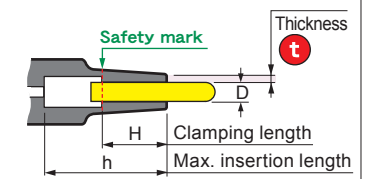



Compatibility table for HRD-01S

[○] Available [x] Not available
 [▲] Usable by raising the heating unit. →P.233
 [★] Use heating coil No. 2.













CV : Curve

Thickness

CODE	Fig.	φD	φC	t	L	M	L1	L2	φC1	φC2	φC3	H	h	kg	N	S	Scale model
A63-SLSA3- 95-M 42	1	3	6	1.5	95	42	27	—	10.4	25	—	9	70	0.7	8.1	9.1	1
-120-M 67					120	67			13				95	0.8	9.2	14.7	4
-125-M 42					125	42	57		10.4				100		8.2	9.8	2
-150-M 67					150	67			13				125		9.3	15.8	5
-M 97						97	27		16.2						10.5	20.5	7
-155-M 42	2				155	42	33	54	10.4	26	40		130	1.2	8.4	9.9	3
-180-M 67					180	67			13	25	39		155	1.1	9.6	15.7	6
-M 97	1					97	57	—	16.2		—			0.9	10.6	22.2	8
-210-M 97	2				210		33	54			39		185	1.2	10.8	22.1	9
-SLRA3- 75-M 22	1	3	7.5	2.25	75	22	27	—	9.8	25	—	9	50	0.7	8.4	2.8	10
- 95-M 42					95	42			11.9				70		8.9	5.3	13
-105-M 22					105	22	57		9.8				80	0.8	8.6	3.2	11
-120-M 67					120	67	27		14.5				95		9.6	8.8	16
-125-M 42					125	42	57		11.9				100		9	6	14
-135-M 22	2				135	22	33	54	9.8		39		110	1.1	8.8	3.2	12
-150-M 67	1				150	67	57	—	14.5		—		125	0.9	9.8	9.9	17
-M 97						97	27		17.7					0.8	10.6	12.9	19
-155-M 42	2				155	42	33	54	11.9	25	39		130	1.1	9.2	6	15
-180-M 67					180	67			14.5	26	40		155	1.2	10	9.8	18
-M 97	1					97	57	—	17.7	25	—			0.9	10.8	14.6	20
-M127						127	27		20.8	36					12.6	15.7	22
-210-M 97	2				210	97	33	54	17.7	25	39		185	1.2	11	14.4	21
-M127	1					127	57	—	20.8	32	—		184	1.1	12.8	16.6	23
-240-M127	2				240		30	57			46		214	1.5	13.2	16.5	24

















CODE	Fig.	φD	φC	t	L	M	L ₁	L ₂	φC ₁	φC ₂	φC ₃	H	h	Kg	N	S	Scale model	Feature	
A63-SLFB3- 75-M 22	1	3	9.5	3.25	75	22	27	—	11.8	25	—	9	50	0.7	8.1	1.9	○	25	Shrink-fit Heater
 - 95-M 42					95	42			13.9				70	0.8	8.5	3.2		28	
-105-M 22					105	22	57		11.8	26			80	0.9	8.2	2.3		26	
-120-M 67					120	67	27		16.5	25			95	0.8	9.7	5.3		31	
-125-M 42					125	42	57		13.9	26			100	0.9	8.7	3.8		29	
-135-M 22	2				135	22	33	54	11.8	25	39		110	1.1	8.5	2.3		27	
-150-M 67	1				150	67	57	—	16.5		—		125	0.9	9.8	6.4		32	
-155-M 42	2				155	42	33	54	13.9		39		130	1.1	8.9	3.9		30	
-180-M 67					180	67			16.5				155	1.2	10	6.4		33	
A63-SLSA4- 95-M 42	1	4	7	1.5	95	42	27	—	11.4	25	—	12	70	0.7	9.2	7.2	○	34	
-120-M 67					120	67			14				95	0.8		11.7		37	
-125-M 42					125	42	57		11.4				100		9.4	7.9		35	
-150-M 67					150	67			14				125	0.9		12.8		38	
-M 97						97	27		17.2					0.8	10.6	16.6		40	
-155-M 42	2				155	42	33	54	11.4		39		130	1.1	9.6	7.9		36	
-180-M 67					180	67			14				155			12.8		39	
-M 97	1					97	57	—	17.2		—			0.9	10.8	18.4		41	
-210-M 97	2				210		33	54			39		185	1.2	11	18.2		42	
-SLRA4- 75-M 22	1	4	10	3	75	22	27	—	12.3	25	—	12	50	0.7	8.6	1.7	○	43	2PIECE type
- 95-M 42					95	42			14.4				70	0.8	9.2	3.1		46	
-105-M 22					105	22	57		12.3				80		8.7	2.2		44	
-120-M 67					120	67	27		17				95		10.3	5.1		49	
-125-M 42					125	42	57		14.4				100		9.3	3.8		47	
-135-M 22	2				135	22	33	54	12.3		39		110	1.1	8.9	2.2		45	
 -150-M 67	1				150	67	57	—	17		—		125	0.9	10.4	6.3		50	
-M 97						97	27		20.2				124	0.8	11.7	7.7		52	
-155-M 42	2				155	42	33	54	14.4		39		130	1.1	9.6	3.8		48	
-180-M 67					180	67			17				155	1.2	10.7	6.2		51	
-M 97	1					97	57	—	20.2		—		154	0.9	11.8	9.5		53	
-M127						127	27		23.3	32				1	14.8	9.4		55	
-210-M 97	2				210	97	33	54	20.2	25	39		184	1.2	12.1			54	
-M127	1					127	57	—	23.3	32	—			1.1	15.1	10.4		56	
-240-M127	2				240		30	57			46		214	1.5	15.4	10.3		57	
-SLFB4- 75-M 22	1	4	12	4	75	22	27	—	14.3	25	—	12	50	0.7	8.4	1.3	○	58	HYPER version
 - 95-M 42					95	42			16.4				70	0.8	9	2.2		61	
-105-M 22					105	22	57		14.3				80		8.5	1.8		59	
-120-M 67					120	67	27		19				95		10.3	3.6		64	
-125-M 42					125	42	57		16.4				100	0.9	9.1	2.9		62	
-135-M 22	2				135	22	33	54	14.3		39		110	1.1	8.7	1.8		60	
-150-M 67	1				150	67	57	—	19		—		125	0.9	10.4	4.7		65	
-155-M 42	2				155	42	33	54	16.4		39		130	1.1	9.4	2.9		63	
-180-M 67					180	67			19				155	1.2	10.6	4.6		66	
-SLSA4- 90 CV	3	4	7	1.5	90	64	—	—	53	—	—	12	65	1	9.3	1.8	○	67	
-120 CV					120	94							95	1.1	10.1	2.7		68	
-150 CV					150	124							125	1.3	11	4		69	
-180 CV					180	154							154	1.4	11.6	6.6		70	
-210 CV					210	184							185		11.8	11.6		71	
-240 CV					240	214							214	1.6	13.1	14		72	
-270 CV					270	244							245	2	15.4	11.9		73	
-300 CV					300	274							275	2.1	16.3	15.9		74	
-SLRA4-120 CV	3	4	10	3	120	94	—	—	53	—	—	12	95	1	8.6	1.9	○	75	PERIPHERALS
-150 CV					150	124							125	1.1	9.3	2.9		76	
-180 CV					180	154							155	1.4	10.9	3.3		77	
-210 CV					210	184							185		11.3	5.6		78	







Feature	CODE	Fig.	φD	φC	t	L	M	L1	L2	φC1	φC2	φC3	H	h	Kg lbs	N	S	Scale model
Shrink-fit Heater	A63-SLSA3/16- 90 CV	3	3/16	.31	.06	3.54	2.52	—	—	2.87	—	—	.59	2.56	1.9	7.6	2	79
	-120 CV					4.72	3.70							3.74	2.2	8.5	2.6	80
	-150 CV					5.91	4.88							4.92	2.5	9.4	4	81
	-180 CV					7.09	6.06							6.06	2.7	10.3	6.5	82
	-210 CV					8.27	7.24							7.24	3.1	11.8	8.4	83
	-240 CV					9.45	8.43							8.43	3.5	12.9	10.6	84
	-270 CV					10.63	9.61							9.61	4.0	14.2	13.2	85
	-300 CV					11.81	10.79							10.83	4.5	15.1	16.1	86
MONO 3° MONO CURVE	-SLRA3/16-120 CV	3	3/16	.42	.12	4.72	3.70	—	—	2.87	—	—	.59	3.70	2.2	8.7	1.8	87
	-150 CV					5.91	4.88							4.88	2.6	10	2.4	88
	-180 CV					7.09	6.06							6.10	2.8	10.2	4.3	89
	-210 CV					8.27	7.24							7.24	3.1	12	5.7	90
MONO Series	A63-SLSA6- 95-M 42	1	6	9	1.5	95	42	27	—	13.4	25	—	18	70	0.7	9.5	4.8	91
	-120-M 67					120	67			16				95	0.8	11.1	8	94
	-125-M 42					125	42	57		13.4				100		9.7	5.6	92
	-150-M 67					150	67			16				125	0.9	11.2	9.3	95
	-M 97						97	27		19.2	32			124		13.4	11	97
	-155-M 42	2				155	42	33	54	13.4	25	39		130	1.1	9.9	5.6	93
	-180-M 67					180	67			16				155		11.5	9.2	96
	-M 97	1					97	57	—	19.2	32	—		154	1	13.6	11.7	98
	-210-M 97	2				210		30	57			46		184	1.4	14		99
	2PIECE type	-SLSB6- 95-M 42	1	6	10	2	95	42	27	—	14.4	25	—	18	70	0.7	10.5	3.7
-120-M 67						120	67			17				95	0.8	12.6	6.2	103
-125-M 42						125	42	57		14.4				100		10.6	4.5	101
-150-M 67						150	67			17				125	0.9	12.7	7.4	104
-M 97							97	27		20.2	32			124		15.4	8.5	106
-155-M 42		2				155	42	33	54	14.4	25	39		130	1.1	10.9	4.4	102
-180-M 67						180	67			17				155		12.9	7.3	105
A63 -M 97		1					97	57	—	20.2	32	—		154	1	15.7	9.2	107
-M127							127	27		23.3					0.9	17.9	11	109
-210-M 97		2				210	97	30	57	20.2		46		184	1.4	16	9.2	108
-M127		1					127	57	—	23.3		—			1.1	18.2	12	110
-M157							157	27		26.5						20.4	13.2	112
-240-M127		2				240	127	30	57	23.3		46		214	1.5	18.5	12	111
-M157		1					157	57	—	26.5		—			1.2	20.7	14.6	113
-270-M157	2				270		30	57			46		244	1.6	21		114	
STRAIGHT anbor	-SLRB6- 75-M 22	1	6	14	4	75	22	27	—	16.3	32	—	18	49	0.8	9.3	1	115
	- 95-M 42					95	42			18.4				69		10.9	1.6	118
	-105-M 22					105	22	57		16.3				79	0.9	9.5	1.2	116
	-120-M 67					120	67	27		21				94		13	2.6	121
	-125-M 42					125	42	57		18.4				99	1	11.2	1.9	119
	-135-M 22	2				135	22	30	57	16.3		46		109	1.3	9.9	1.2	117
	-150-M 67	1				150	67	57	—	21		—		124	1	13.2	3	122
	-155-M 42	2				155	42	30	57	18.4		46		129	1.4	11.5	1.9	120
	-180-M 67					180	67			21				154		13.6	3.1	123
	PERIPHERALS	-SLFB6- 75-M 22	1	6	14	4	75	22	27	—	16.3	32	—	18	49	0.8	9.3	1
 - 95-M 42						95	42			18.4				69		10.9	1.6	127
-105-M 22						105	22	57		16.3				79	0.9	9.5	1.2	125
-120-M 67						120	67	27		21				94		13	2.6	130
-125-M 42						125	42	57		18.4				99	1	11.2	1.9	128
-135-M 22		2				135	22	30	57	16.3		46		109	1.3	9.9	1.2	126
-150-M 67		1				150	67	57	—	21		—		124	1	13.2	3	131
-155-M 42		2				155	42	30	57	18.4		46		129	1.4	11.5	1.9	129
-180-M 67						180	67			21				154		13.6	3.1	132

CODE	Fig.	φD	φC	t	L	M	L ₁	L ₂	φC ₁	φC ₂	φC ₃	H	h					Scale model					
A63-SLSA6- 90 CV	3	6	9	1.5	90	64	—	—	53	—	—	18	65	1	9.4	1.6		133					
-120 CV					120	94	95	1.1					10.1	2.3	134								
-150 CV					150	124	125	1.3					11	3.6	135								
-180 CV					180	154	154	1.4					11.7	5.7	136								
-210 CV					210	184	184	1.6					13	7.3	137								
-240 CV					240	214	214						13.3	12	138								
-270 CV					270	244	245	2.1					16.3	8.5	139								
-300 CV					300	274	275	2.3					17.2	11.7	140								
-SLRA6- 90 CV	3	6	13	3.5	90	64	—	—	53	—	—	18	65	1	8.3	0.8		141					
-120 CV					120	94	95	1.1					9.3	1.2	142								
-150 CV					150	124	125	1.3					10.1	1.9	143								
-180 CV					180	154	155	1.4					11.1	2.8	144								
-210 CV					210	184	185						11.5	4.8	145								
-SLFA6- 90 CV	3	6	13	3.5	90	64	—	—	53	—	—	18	65	1	8.3	0.8		146					
 -120 CV					120	94	95	1.1					9.3	1.2	147								
-150 CV					150	124	125	1.3					10.1	1.9	148								
-180 CV					180	154	155	1.4					11.1	2.8	149								
-210 CV					210	184	185						11.5	4.8	150								
A63-SLSA1/4- 90 CV					3	1/4	.37	.06					3.54	2.52	—	—		2.87	—	—	.71	2.56	1.9
-120 CV	4.72	3.70	3.74	2.2					8.5	2.4	152												
 -150 CV	5.91	4.88	4.92	2.5					9.4	3.7	153												
-180 CV	7.09	6.06	6.10	2.8					10.4	5.5	154												
-210 CV	8.27	7.24	7.24	3.1					12.1	7.5	155												
-240 CV	9.45	8.43	8.43	3.5					13.2	9.6	156												
-270 CV	10.63	9.61	9.65	4.1					14.2	11.3	157												
-300 CV	11.81	10.79	10.79	4.7					16.9	11.8	158												
-SLRA1/4- 90 CV	3	1/4	.53	.14					3.54	2.52	—	—	2.87	—	—	.71	2.52					2.1	8.4
-120 CV					4.72	3.70	3.74	2.5	9.2	1.2	160												
-150 CV					5.91	4.88	4.92	2.8	10.2	1.9	161												
-180 CV					7.09	6.06	6.06	3.1	11.6	2.9	162												
-210 CV					8.27	7.24	7.24	3.2	12.2	4.9	163												
-SLFA1/4- 90 CV	3	1/4	.53	.14	3.54	2.52	—	—	2.87	—	—	.71	2.52	2.1	8.4	0.8		164					
 -120 CV					4.72	3.70	3.74	2.5					9.2	1.2	165								
-150 CV					5.91	4.88	4.92	2.8					10.2	1.9	166								
-180 CV					7.09	6.06	6.06	3.1					11.6	2.9	167								
-210 CV					8.27	7.24	7.24	3.2					12.2	4.9	168								
A63-SLSA8- 95-M 42	1	8	11	1.5	95	42	27	—	15.4	25	—	24	70	0.7	11.4	3.4		169					
-120-M 67					120	67		18	32		94		0.8	14	5.4	172							
-125-M 42					125	42	57	15.4	25		100			11.6	4.3	170							
-150-M 67					150	67		18	32		124		1	14.2	5.9	173							
-M 97						97	27	21.2					0.9	17.1	7.9	175							
-155-M 42					2			155	42	33	54		15.4	25	39			130	1.1	12	4.3	171	
-180-M 67						180	67	30	57	18	32		46		154	1.4		14.6	5.9	174			
-M 97					1				97	57	—		21.2		—				1	17.4	8.7	176	
-210-M 97	2				210	30	57			46		184	1.4	17.7		177							
-SLSB8- 95-M 42	1	8	13	2.5	95	42	27	—	17.4	32	—	24	69	0.8	12.5	2.1		178					
-120-M 67					120	67		20			94		0.9	15.7	3.5	181							
-125-M 42					125	42	57	17.4			99		1	12.7	2.4	179							
-150-M 67					150	67		20			124			15.9	4	182							
-M 97						97	27	23.2					0.9	19.5	5.2	184							
-155-M 42					2			155	42	30	57		17.4		46			129	1.4	13.1	2.4	180	
-180-M 67						180	67		20				154		16.3	4		183					
-M 97					1				97	57	—		23.2		—				1.1	19.8	6	185	
-M127							127	27	26.3					1	23.4	7		187					
-210-M 97					2				210	97	30		57	23.2		46			184	1.5	20.2	6	186
-M127						1				127	57		—	26.3		—				1.2	23.7	8.1	188
-M157					157	27		29.5	42			185		27.3	8	190							
-240-M127	2				240	127	30	57	26.3	32	46		214	1.6	24	8.1	189						
-M157		1				157	57	—	29.5	42	—			1.5	27.5	8.6	191						
-270-M157	2				270		28	59			53		242	2	27.9	8.7	192						

CODE	Fig.	φD	φC	t	L	M	L ₁	L ₂	φC ₁	φC ₂	φC ₃	H	h					Scale model
A63-SLRB8- 75-M 22	1	8	18	5	75	22	27	—	20.3	32	—	24	49	0.8	10	0.7	×	193
- 95-M 42					95	42			22.4				69	0.9	12.5	1.1	○	196
-105-M 22					105	22	57		20.3				79	1	10.2	0.9	×	194
-120-M 67					120	67	27		25				94	0.9	15.7	1.7	○	199
-125-M 42					125	42	57		22.4				99	1	12.8	1.4		197
-135-M 22	2				135	22	30	57	20.3		46		109	1.4	10.6	1	×	195
-150-M 67	1				150	67	57	—	25		—		124	1.1	16	2.2	○	200
-155-M 42	2				155	42	30	57	22.4		46		129	1.4	13.2	1.4		198
-180-M 67					180	67			25				155	1.5	16.4	2.2		201
-SLFB8- 75-M 22	1	8	18	5	75	22	27	—	20.3	32	—	24	49	0.8	10	0.7	×	202
- 95-M 42					95	42			22.4				69	0.9	12.5	1.1	○	205
-105-M 22					105	22	57		20.3				79	1	10.2	0.9	×	203
-120-M 67					120	67	27		25				94	0.9	15.7	1.7	○	208
-125-M 42					125	42	57		22.4				99	1	12.8	1.4		206
-135-M 22	2				135	22	30	57	20.3		46		109	1.4	10.6	1	×	204
-150-M 67	1				150	67	57	—	25		—		124	1.1	16	2.2	○	209
-155-M 42	2				155	42	30	57	22.4		46		129	1.4	13.2	1.4		207
-180-M 67					180	67			25				154	1.5	16.4	2.2		210
-SLSA8- 90 CV	3	8	11	1.5	90	64	—	—	53	—	—	24	65	1	9.4	1.4	○	211
-120 CV					120	94							94	1.1	10.3	2		212
A63 -150 CV					150	124							124	1.3	11.5	2.7		213
-180 CV					180	154							155	1.4	11.8	5		214
-210 CV					210	184							184	1.6	13.2	6.6	▲	215
-240 CV					240	214							214	1.8	14.4	8.3		216
-270 CV					270	244							244	2.2	17.2	6.9		217
-300 CV					300	274							274	2.4	18.5	8.9		218
-SLRA8- 90 CV	3	8	16	4	90	64	—	—	53	—	—	24	65	1	8.4	0.7	○	219
-120 CV					120	94							95	1.2	9.6	1		220
-150 CV					150	124							125	1.4	10.8	1.4		221
-180 CV					180	154							155	1.5	12	2		222
-210 CV					210	184							185	1.6	12.5	3.5		223
-SLFA8- 90 CV	3	8	16	4	90	64	—	—	53	—	—	24	65	1	8.4	0.7	○	224
-120 CV					120	94							95	1.2	9.6	1		225
-150 CV					150	124							125	1.4	10.8	1.4		226
-180 CV					180	154							155	1.5	12	2		227
-210 CV					210	184							185	1.6	12.5	3.5		228
A63-SLSA5/16- 90 CV	3	5/16	.43	.06	3.54	2.52	—	—	2.09	—	—	.94	2.56	1.9	7.7	1.5	○	229
-120 CV					4.72	3.70							3.70	2.2	8.9	2		230
-150 CV					5.91	4.88							4.88	2.6	10.2	2.8		231
-180 CV					7.09	6.06							6.10	2.7	10.4	5.2		232
-210 CV					8.27	7.24							7.17	3.1	13.6	6		233
-240 CV					9.45	8.43							8.43	3.8	14.5	6.8	▲	234
-270 CV					10.63	9.61							9.65	4.4	15.1	8.5		235
-300 CV					11.81	10.79							10.79	5.0	18.1	9		236
-SLRA5/16- 90 CV	3	5/16	.63	.16	3.54	2.52	—	—	2.09	—	—	.94	2.52	2.1	8.4	0.7	○	237
-120 CV					4.72	3.70							3.70	2.6	9.8	1		238
-150 CV					5.91	4.88							4.88	3.0	11.1	1.5		239
-180 CV					7.09	6.06							6.06	3.4	12.5	2.1		240
-210 CV					8.27	7.24							7.24	3.5	13.4	3.6		241
-SLFA5/16- 90 CV	3	5/16	.63	.16	3.54	2.52	—	—	2.09	—	—	.94	2.52	2.1	8.4	0.7	○	242
-120 CV					4.72	3.70							3.70	2.6	9.8	1		243
-150 CV					5.91	4.88							4.88	3.0	11.1	1.5		244
-180 CV					7.09	6.06							6.06	3.4	12.5	2.1		245
-210 CV					8.27	7.24							7.24	3.5	13.4	3.6		246





CODE	Fig.	φD	φC	t	L	M	L ₁	L ₂	φC ₁	φC ₂	φC ₃	H	h	Kg	N	S	Scale model	Feature		
A63-SLSA10- 95-M 42	1	10	13	1.5	95	42	27	—	17.4	25	—	30	70	0.8	12.8	2.6	○	247	Shrink-fit Heater	
-120-M 67					120	67			20	32			94		16.6	4		250		
-125-M 42					125	42	57		17.4	25			100		13	3.6		248		
-150-M 67					150	67			20	32			124	1	16.9	4.6		251		
-M 97						97	27		23.2					0.9	21.3	6		253		
-155-M 42	2				155	42	33	54	17.4	25	39		130	1.1	13.4	3.5		249		
-180-M 67					180	67	30	57	20	32	46		154	1.4	17.3	4.6		252		
-M 97	1					97	57	—	23.2		—			1.1	21.6	6.9		254		
-210-M 97	2				210		30	57			46		184	1.5	21.9			255		
-SLSB10- 95-M 42	1	10	16	3	95	42	27	—	20.4	32	—	30	69	0.8	13.9	1.4	○	256		MONO 3° MONO CURVE
-120-M 67					120	67			23				94	0.9	18.5	2.4		259		
-125-M 42					125	42	57		20.4				99	1	14.2	1.8		257		
-150-M 67					150	67			23				124		18.8	3		260		
-M 97						97	27		26.2						24	3.6		262		
-155-M 42	2				155	42	30	57	20.4	32	46		129	1.4	14.6	1.8		258		
-180-M 67					180	67			23				154		19.2	3		261		
A63 -M 97	1					97	57	—	26.2		—			1.1	24.3	4.5		263		
-M127						127	27		29.3	42			155	1.2	30.2			265		
-210-M 97	2				210	97	30	57	26.2	32	46		184	1.5	24.7			264		
-M127	1					127	57	—	29.3	42	—		182	1.4	31	4.9		266		
-M157						157	27		32.5				185	1.3	35.7	5.6		268		
-240-M127	2				240	127	28	59	29.3		53		212	1.9	31.8	5.0	▲	267		
-M157	1					157	57	—	32.5		—		215	1.8	36.5	5.8		269		
-270-M157	2				270		28	59			53		242	2.1	37.4	6.2		270		
-SLRB10- 75-M 22	1	10	22	6	75	22	27	—	24.3	32	—	30	49	0.8	10.3	0.6	×	271	UNO	
- 95-M 42					95	42			26.4				68	0.9	14	0.8	○	274		
-105-M 22					105	22	57		24.3				79	1	10.6		×	272		
-120-M 67					120	67	27		29	42			94	1.1	18.6	1.1	○	277		
-125-M 42					125	42	57		26.4	32			99		14.2	1.2		275		
-135-M 22	2				135	22	30	57	24.3		46		109	1.4	10.9	0.9	×	273		
-150-M 67	1				150	67	57	—	29	42	—		124	1.3	18.9	1.3	○	278		
-155-M 42	2				155	42	30	57	26.4	32	46		129	1.5	14.6	1.2		276		
-180-M 67					180	67	28	59	29	42	53		154	1.8	19.2	1.3		279		
-SLFB10- 75-M 22	1	10	22	6	75	22	27	—	24.3	32	—	30	49	0.8	10.3	0.6	×	280		STRAIGHT arbor
- 95-M 42					95	42			26.4				69	0.9	14	0.8	○	283		
-105-M 22					105	22	57		24.3				79	1	10.6		×	281		
-120-M 67					120	67	27		29	42			94	1.1	18.6	1.1	○	286		
-125-M 42					125	42	57		26.4	32			99		14.2	1.2		284		
-135-M 22	2				135	22	30	57	24.3		46		109	1.4	10.9	0.9	×	282		
-150-M 67	1				150	67	57	—	29	42	—		124	1.3	18.9	1.3	○	287		
-155-M 42	2				155	42	30	57	26.4	32	46		129	1.5	14.6	1.2		285		
-180-M 67					180	67	28	59	29	42	53		154	1.8	19.2	1.3		288		
-SLSA10- 90 CV	3	10	13	1.5	90	64	—	—	53	—	—	30	65	1	9.4	1.3	○	289	PERIPHERALS	
-120 CV					120	94							95	1.3	10.9			290		
-150 CV					150	124							125	1.4	11.8	2.2		291		
-180 CV					180	154							154	1.6	12.9	3.4		292		
-210 CV					210	184							184		13.3	6		293		
-240 CV					240	214							212	2.1	16	5.8	▲	294		
-270 CV					270	244							244		17.5	6.6		295		
-300 CV					300	274							274	2.3	18.7	8.6		296		



CODE	Fig.	φD	φC	t	L	M	L ₁	L ₂	φC ₁	φC ₂	φC ₃	H	h					Scale model					
A63-SLRA10- 90 CV	3	10	19	4.5	90	64	—	—	53	—	—	30	65	1	8.5	0.6		297					
-120 CV					120	94	95	1.2					9.6	0.9		298							
-150 CV					150	124	125	1.3					10.9	1.4	299								
-180 CV					180	154	155	1.5					12.1	2	300								
-210 CV					210	184	185	1.6					13.3	3.1	301								
-SLFA10- 90 CV	3	10	19	4.5	90	64	—	—	53	—	—	30	65	1	8.5	0.6		302					
-120 CV					120	94	95	1.2					9.6	0.9		303							
-150 CV					150	124	125	1.3					10.9	1.4	304								
-180 CV					180	154	155	1.5					12.1	2	305								
-210 CV					210	184	185	1.6					13.3	3.1	306								
A63-SLSA3/8- 90 CV	3	3/8	.49	.06	3.54	2.52	—	—	2.09	—	—	1.18	2.56	1.9	7.7	1.3		307					
-120 CV					4.72	3.70	3.74	2.2					8.7	2.2	308								
-150 CV					5.91	4.88	4.88	2.6					10.4	2.6	309								
-180 CV					7.09	6.06	6.06	3.0					11.8	3.6	310								
-210 CV					8.27	7.24	7.24	3.4					13.4	4.9	311								
-240 CV					9.45	8.43	8.46	4.0					14.2	6	312								
-270 CV					10.63	9.61	9.61	4.5					17.1	6.8	313								
-300 CV					11.81	10.79	10.79	5.0					18.5	8.8	314								
-SLRA3/8- 90 CV	3	3/8	.73	.185	3.54	2.52	—	—	2.09	—	—	1.18	2.52	2.1	8.4	0.7		315					
-120 CV					4.72	3.70	3.70	2.6					9.7	1		316							
-150 CV					5.91	4.88	4.88	3.0					11.2	1.4	317								
-180 CV					7.09	6.06	6.06	3.4					12.7	2	318								
-210 CV					8.27	7.24	7.28	3.8					13.2	2.9	319								
-SLFA3/8- 90 CV	3	3/8	.73	.185	3.54	2.52	—	—	2.09	—	—	1.18	2.52	2.1	8.4	0.7		320					
-120 CV					4.72	3.70	3.70	2.6					9.7	1		321							
-150 CV					5.91	4.88	4.88	3.0					11.2	1.4	322								
-180 CV					7.09	6.06	6.06	3.4					12.7	2	323								
-210 CV					8.27	7.24	7.28	3.8					13.2	2.9	324								
A63-SLSA12- 95-M 42	1	12	15	1.5	95	42	27	—	19.4	32	—	30	69	0.8	15.2	1.8		325					
-120-M 67					120	67	—	22					94	20.6	3.3	328							
-125-M 42					125	42	57	19.4					99	1	15.4	2.3	326						
-150-M 67					150	67	—	22					124	20.8	3.9	329							
-M 97					97	27	—	25.2					—	0.9	27.5	4.9	331						
-155-M 42					2	155	42	30					57	19.4	—	46	129	1.4	15.8	2.3	327		
-180-M 67						180	67	—					22	154	21.2	3.9	330						
-M 97					1	97	57	—					25.2	—	—	—	—	1.1	27.8	5.8	332		
-210-M 97					2	210	30	57					—	46	—	—	—	184	1.5	28.2	—		333
-SLSB12- 95-M 42					1	12	19	3.5					95	42	27	—	23.4	32	—	30	69	0.8	16.5
-120-M 67	120	67	—	26					94	0.9	22.8	1.8	337										
-125-M 42	125	42	57	23.4					99	1	16.8	1.5	335										
-150-M 67	150	67	—	26					124	1.1	23.1	2.5	338										
-M 97	97	27	—	29.2					42	—	—	—	125	30.9	2.4	340							
-155-M 42	2	155	42	30					57	23.4	32	46	129	1.4	17.2	1.6					336		
-180-M 67		180	67	—					26	154	1.5	23.4	2.5	339									
-M 97	1	97	57	—					29.2	42	—	—	152	1.4	31.7	2.8					341		
-M127		127	27	—					32.3	—	—	—	155	1.3	38.5	3.3					343		
-210-M 97		210	97	87					29.2	50	—	—	180	1.9	32.6	2.8						342	
-M127		127	57	—	32.3	—	—	—	—	1.7	39.3	3.5	344										
-M157	157	27	—	35.5	42	—	—	—	185	1.4	46	4.1	346										
-240-M127	240	127	87	32.3	50	—	—	—	215	2.1	40.1	3.8	345										
-M157	157	57	—	35.5	42	—	—	—	212	1.7	46.8	4.7	347										
-270-M157	2	270	28	59	—	—	—	53	—	—	—	—	—	242	2.2	47.7	4.8	348					

CODE	Fig.	φD	φC	t	L	M	L ₁	L ₂	φC ₁	φC ₂	φC ₃	H	h					Scale model
A63-SLRB12- 75-M 22	1	12	26	7	75	22	27	—	28.3	42	—	30	50	0.9	14.5	0.4	×	349
- 95-M 42					95	42			30.4				70	1	17.2	0.6		352
-105-M 22					105	22	57		28.3				77	1.2	15.3	0.5		350
-120-M 67					120	67	27		33				95		23.5	0.8		355
-125-M 42					125	42	57		30.4				97	1.3	18	0.7		353
-135-M 22	2				135	22	28	59	28.3		53		107	1.7	16.2	0.6		351
-150-M 67	1				150	67	57	—	33		—		122	1.4	24.3	1.1		356
-155-M 42	2				155	42	28	59	30.4		53		127	1.8	18.9	0.8		354
-180-M 67					180	67			33				152	1.9	25.2	1.1		357
-SLFB12- 75-M 22	1	12	26	7	75	22	27	—	28.3	42	—	30	50	0.9	14.5	0.4	×	358
 - 95-M 42					95	42			30.4				70	1	17.2	0.6		361
-105-M 22					105	22	57		28.3				77	1.2	15.3	0.5		359
-120-M 67					120	67	27		33				95		23.5	0.8		364
-125-M 42					125	42	57		30.4				97	1.3	18	0.7		362
-135-M 22	2				135	22	28	59	28.3		53		107	1.7	16.2	0.6		360
-150-M 67	1				150	67	57	—	33		—		122	1.4	24.3	1.1		365
-155-M 42	2				155	42	28	59	30.4	42	53		127	1.8	18.9	0.8		363
-180-M 67					180	67			33				152	1.9	25.2	1.1		366
-SLSA12- 90 CV	3	12	15	1.5	90	64	—	—	53	—	—	30	64	1.1	9.9	0.9	○	367
-120 CV					120	94							94	1.3	11.3	1.2		368
-150 CV					150	124							124	1.4	11.8	2.4		369
A63 -180 CV					180	154							154	1.6	13	3.3		370
-210 CV					210	184							184	1.8	14.3	4.6		371
-240 CV					240	214							212	2.1	16.2	5.5	▲	372
-270 CV					270	244							244	2.3	18.4	5.4		373
-SLRA12- 90 CV	3	12	22	5	90	64	—	—	53	—	—	30	64	1	8.5	0.6	×	374
-120 CV					120	94							94	1.3	10.4	0.7		375
-150 CV					150	124							124	1.5	11.7	1.1	○	376
-180 CV					180	154							154		12.8	1.8		377
-210 CV					210	184							184	1.6	14	2.8		378
-SLFA12- 90 CV	3	12	22	5	90	64	—	—	53	—	—	30	64	1	8.5	0.6	×	379
 -120 CV					120	94							94	1.3	10.4	0.7		380
-150 CV					150	124							124	1.5	11.7	1.1	○	381
-180 CV					180	154							154		12.8	1.8		382
-210 CV					210	184							184	1.6	14	2.8		383
A63-SLSA1/2- 90 CV	3	1/2	.62	.06	3.54	2.52	—	—	2.09	—	—	1.18	2.52	2.1	8.4	0.8	○	384
-120 CV					4.72	3.70							3.70	2.5	10	1.2		385
-150 CV					5.91	4.88							4.88		10.9	2.4		386
-180 CV					7.09	6.06							6.06	2.9	12.4	3.4		387
-210 CV					8.27	7.24							7.17	3.5	16.3	3.6		388
-240 CV					9.45	8.43							8.35	4.0	19.1	4.3	▲	389
-270 CV					10.63	9.61							9.53	4.7	20.9	5.1		390
-SLRA1/2- 90 CV	3	1/2	.89	.20	3.54	2.52	—	—	2.09	—	—	1.18	2.44	2.2	9.3	0.5	×	391
-120 CV					4.72	3.70							3.70	2.8	10.6	0.7		392
-150 CV					5.91	4.88							4.88	3.2	12.1	1.1	○	393
-180 CV					7.09	6.06							5.98		15.5	1.9		394
-210 CV					8.27	7.24							7.24	4.4	15.7	2		395
-SLFA1/2- 90 CV	3	1/2	.89	.20	3.54	2.52	—	—	2.09	—	—	1.18	2.44	2.2	9.3	0.5	×	396
 -120 CV					4.72	3.70							3.70	2.8	10.6	0.7		397
-150 CV					5.91	4.88							4.88	3.2	12.1	1.1	○	398
-180 CV					7.09	6.06							5.98		15.5	1.9		399
-210 CV					8.27	7.24							7.24	4.4	15.7	2		400

Feature
Shrink-fit Heater
MONO 3° MONO CURVE
MONO Series
2PIECE type
UNO
HYPER version
STRAIGHT arbor
OTHERS
PERIPHERALS
Technical Information

Feature
Shrink-fit Heater
MONO 3° MONO CURVE
MONO Series
2PIECE type
UNO
HYPER version
STRAIGHT anbor
OTHERS
PERIPHERALS
Technical Information

CODE	Fig.	φD	φC	t	L	M	L ₁	L ₂	φC ₁	φC ₂	φC ₃	H	h				Scale model
A63-SLSB16- 95-M 42	1	16	24	4	95	42	27	—	28.4	42	—	32	70	1	22.7	0.7	401
-120-M 67					120	67			31				95	1.1	33	1.1	404
-125-M 42					125	42	57		28.4				97	1.2	23.5	0.9	402
-150-M 67					150	67			31				122	1.3	33.8	1.4	405
-M 97						97	27		34.2				125	1.2	45.5	1.7	407
A63 -155-M 42					155	42	87		28.4	50			130	1.7	24.4	0.9	403
-180-M 67	2				180	67	28	59	31	42	53		152	1.8	34.7	1.5	406
-M 97	1					97	57	—	34.2		—		1.4	46.3	2.1	408	
-M127					127	27			37.3	53			155	1.5	57.9		410
-210-M 97	2				210	97	28	59	34.2	42	53		182	2	47.1		409
-M127	1				127	57	—		37.3	53	—		181	1.9	58.7	2.3	411
-M157					157	27			40.5				185	1.7	70.3	2.7	413
-240-M127					240	127	87		37.3				211	2.3	59.5	2.6	412
-M157						157	57		40.5				215	2.1	71.1	2.9	414
-270-M157					270		87						241	2.5	72	3.2	415
-SLRB16- 75-M 22	1	16	32	8	75	22	27	—	34.3	42	—	32	50	1	14.5	0.3	416
- 95-M 42					95	42			36.4				70	1.1	22.8	0.5	419
-105-M 22					105	22	57		34.3				77	1.2	15.3		417
-120-M 67					120	67	27		39				95	1.3	33.2	0.7	422
-125-M 42					125	42	57		36.4				97		23.6		420
-135-M 22	2				135	22	28	59	34.3		53		107	1.7	16.2	0.5	418
-150-M 67	1				150	67	57	—	39		—		122	1.5	34	0.9	423
-155-M 42	2				155	42	28	59	36.4		53		127	1.9	24.5	0.7	421
-180-M 67					180	67			39				152	2	34.9	1	424
-SLFB16- 75-M 22	1	16	32	8	75	22	27	—	34.3	42	—	32	50	1	14.5	0.3	425
 - 95-M 42					95	42			36.4				70	1.1	22.8	0.5	428
-105-M 22					105	22	57		34.3				77	1.2	15.3		426
-120-M 67					120	67	27		39				95	1.3	33.2	0.7	431
-125-M 42					125	42	57		36.4				97		23.6		429
-135-M 22	2				135	22	28	59	34.3		53		107	1.7	16.2	0.5	427
-150-M 67	1				150	67	57	—	39	50	—		120		34	0.7	432
-155-M 42	2				155	42	28	59	36.4	42	53		127	1.9	24.5		430
-180-M 67					180	67			39				152	2	34.9	1	433
-SLSB16- 90 CV	3	16	21	2.5	90	64	—	—	53	—	—	32	62	1.1	10.5	0.6	434
-120 CV					120	94							92	1.5	12.4	0.8	435
-150 CV					150	124							122	1.6	13.5	1.5	436
-180 CV					180	154							152	1.9	15.4	1.9	437
-210 CV					210	184							182	2.1	16.5	3	438
-240 CV					240	214							212	2.4	18.4	3.7	439
-270 CV					270	244							242	2.7	20.3	4.6	440
A63-SLSB5/8- 90 CV	3	5/8	.82	.10	3.54	2.52	—	—	2.09	—	—	1.26	2.44	2.1	9.3	0.6	441
-120 CV					4.72	3.70							3.62	2.6	11.7	0.8	442
-150 CV					5.91	4.88							4.80	2.9	13.4	1.5	443
-180 CV					7.09	6.06							5.98	3.4	15.8	1.9	444
-210 CV					8.27	7.24							7.17	3.6	17.5	3	445
-240 CV					9.45	8.43							8.35	4.2	19.9	3.7	446
-270 CV					10.63	9.61							9.53	4.8	22.3	4.6	447

CODE	Fig.	φD	φC	t	L	M	L ₁	L ₂	φC ₁	φC ₂	φC ₃	H	h	Kg lbs	N	S	Scale model
A63-SLSB20- 95-M 42	1	20	29	4.5	95	42	27	—	33.4	42	—	40	70	1	25.4	0.5	448
-120-M 67					120	67			36				95	1.1	40.8	0.9	451
-125-M 42					125	42	57		33.4				97	1.2	26.2	0.8	449
-150-M 67					150	67			36				122	1.4	41.6	1.2	452
-M 97						97	27		39.2	53			125		59.3	1.1	454
A63 -155-M 42					155	42	87		33.4	50			130	1.8	27.1	0.8	450
-180-M 67	2				180	67	28	59	36	42	53		152	1.9	42.5	1.2	453
-M 97	1					97	57	—	39.2	53	—		151	1.8	60.1	1.3	455
-M127						127	27		42.3				155	1.6	79.1	1.5	457
-210-M 97					210	97	87		39.2				181	2.2	61	1.6	456
-M127						127	57		42.3				2	79.9	1.8	458	
-M157						157	27		45.5				185	1.9	97.6	1.9	460
-240-M127					240	127	87		42.3				211	2.3	80.7	2.1	459
-M157						157	57		45.5				2	98.4	2.2	461	
-270-M157					270		87						241	2.7	99.3	2.6	462
-SLRB20- 95-M 42	1	20	38	9	95	42	27	—	42.4	53	—	40	70	1.3	25.6	0.3	463
-120-M 67					120	67			45				95	1.5	41	0.5	466
-125-M 42					125	42	57		42.4				96	1.7	26.4	0.4	464
-150-M 67					150	67			45				121	1.9	41.8	0.6	467
-155-M 42					155	42	87		42.4				126	2.1	27.2		465
-180-M 67					180	67			45				151	2.3	42.7	0.8	468
-SLFB20- 95-M 42	1	20	38	9	95	42	27	—	42.4	53	—	40	70	1.3	25.6	0.3	469
 -120-M 67					120	67			45				95	1.5	41	0.5	472
-125-M 42					125	42	57		42.4				96	1.7	26.4	0.4	470
-150-M 67					150	67			45				121	1.9	41.8	0.6	473
-155-M 42					155	42	87		42.4	50			125	2	27.2	0.6	471
-180-M 67					180	67			45	53			151	2.3	42.7	0.8	474
-SLSB20- 90 CV	3	20	26	3	90	64	—	—	51	—	—	40	62	1.2	10.7	0.5	475
-120 CV					120	94			53				92	1.5	12.8	0.8	476
-150 CV					150	124							122	1.7	14.1	1.3	477
-180 CV					180	154							152	2	16.2	1.8	478
-210 CV					210	184							182	2.4	18.2	2.3	479
-240 CV					240	214							212	2.7	20.2	3	480
-270 CV					270	244							242	3.1	22.8	3.4	481
A63-SLSB3/4- 90 CV	3	3/4	.99	.12	3.54	2.52	—	—	2.09	—	—	1.50	2.44	2.1	9.5	0.6	482
-120 CV					4.72	3.70							3.62	2.6	12.2	0.8	483
-150 CV					5.91	4.88							4.80	2.9	14.5	1.4	484
-180 CV					7.09	6.06							5.98	3.4	17.1	1.8	485
-210 CV					8.27	7.24							7.17	3.9	19.8	2.4	486
-240 CV					9.45	8.43							8.35	4.5	22.4	3.1	487
-270 CV					10.63	9.61							9.53	5.0	25	3.9	488
A63-SLRB25- 95-M 42	1	25	45	10	95	42	27	—	49.4	53	—	45	70	1.4	28.7	0.3	489
-125-M 42					125		57						96	1.8	29.5	0.4	490
-155-M 42					155		87						126	2.2	30.4	0.6	491
-SLFB25- 95-M 42	1	25	45	10	95	42	27	—	49.4	53	—	45	70	1.4	28.7	0.3	492
 -125-M 42					125		57						96	1.8	29.5	0.4	493
-155-M 42					155		87						126	2.2	30.4	0.6	494
A63-SLRB32-110-M 42	1	32	54	11	110	42	42	—	58.4	63	—	50	84	1.8	13.3	0.3	495

■ Cleaning tool for a spindle taper hole, STAR DUST

CODE
CLT-A63-G3

● P.226



■ φ70 Nozzle (HRB-03S)
Required for shrinking the SLRB32.

CODE
HRB-NZL70





HEAT ROBO Baby 3000S

300 Variations

SYSTEM HSK-A63

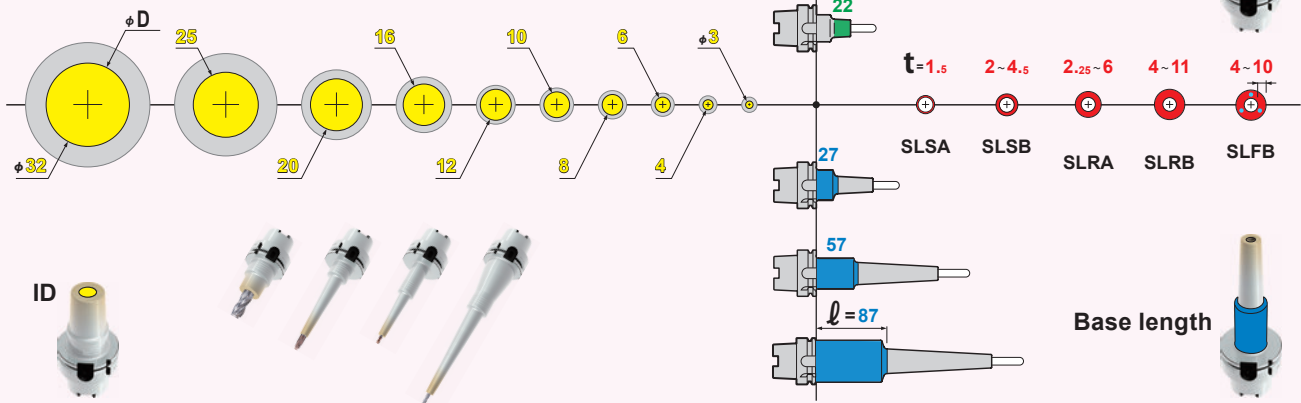
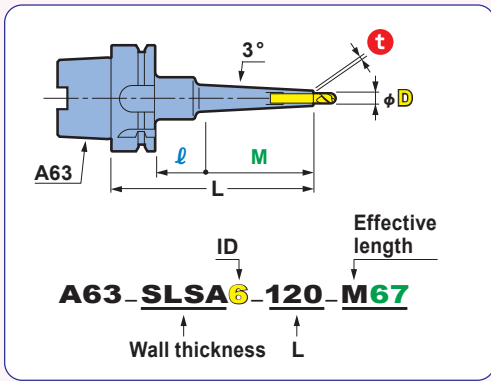
You can select the optimum holder for all kinds of applications from a lineup with 300 variations in **ID**, **Base length**, **Effective length**, and **Wall thickness**



Feature: Shrink-fit Heater, MONO 3° MONO CURVE, MONO Series, 2PIECE type, UNO, HYPER version, STRAIGHT anbor, OTHERS, PERIPHERALS, Technical Information

φ 3

<p>A63-SLSA3-95-M42</p>	<p>A63-SLSA3-125-M42</p>	<p>A63-SLSA3-155-M42</p>	<p>A63-SLSA3-120-M67</p>
<p>A63-SLSA3-150-M67</p>	<p>A63-SLSA3-180-M67</p>	<p>A63-SLSA3-150-M97</p>	<p>A63-SLSA3-180-M97</p>

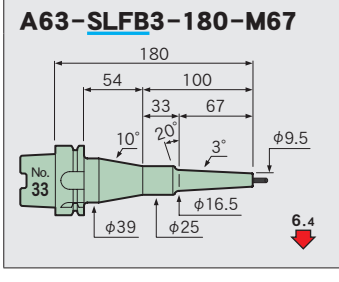
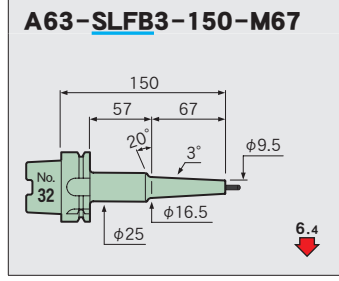
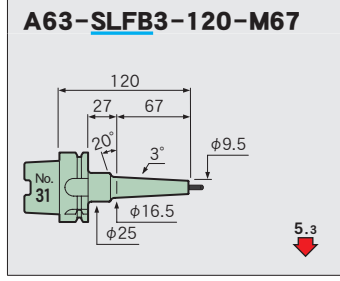
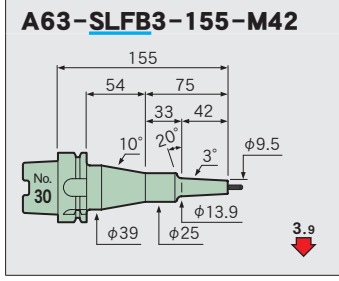
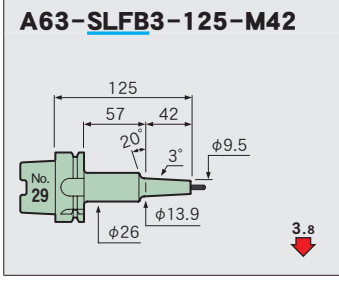
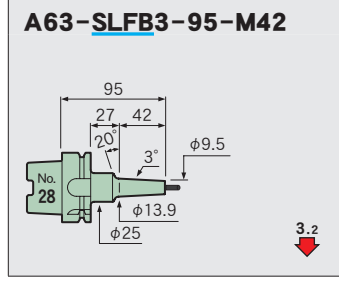
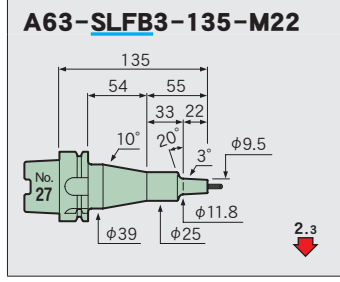
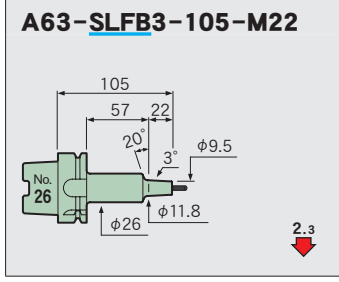
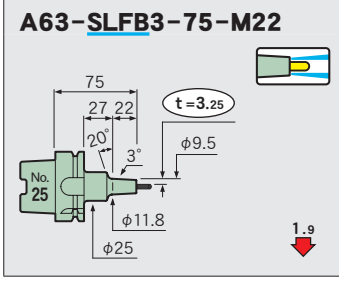
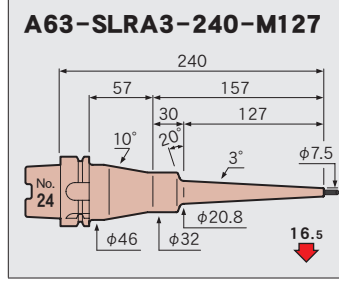
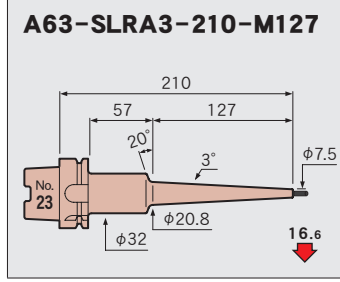
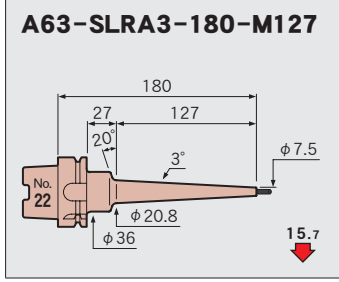
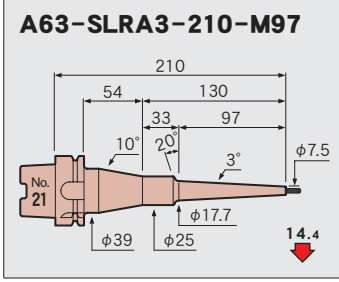
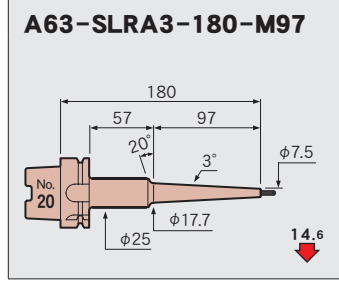
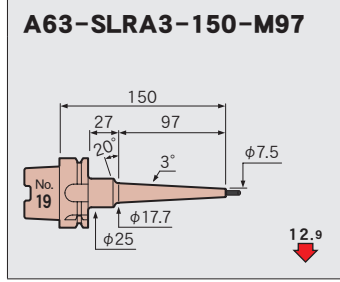
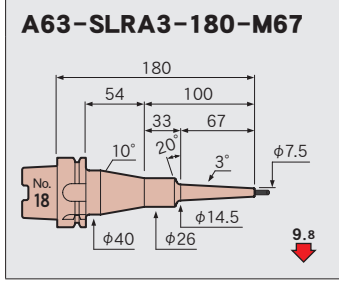
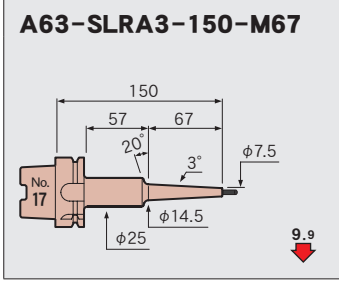
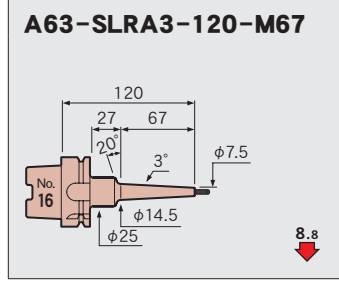
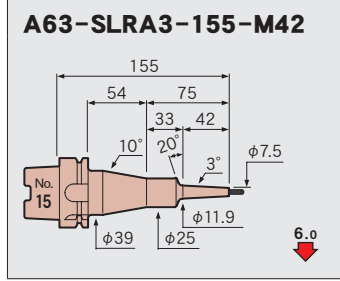
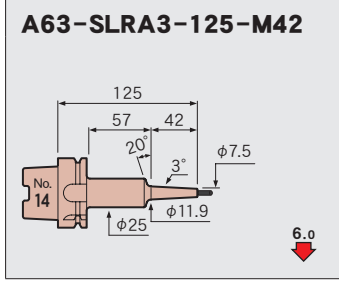
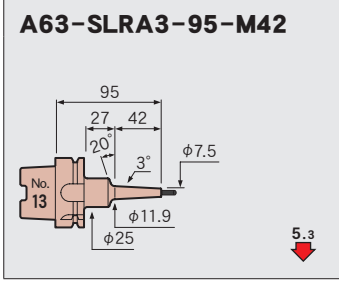
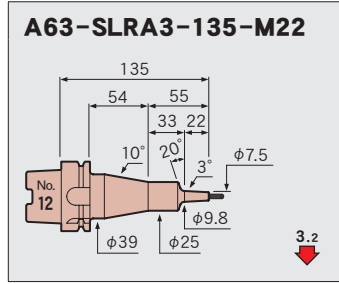
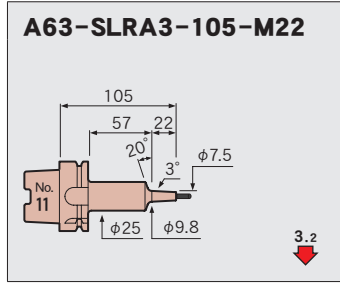
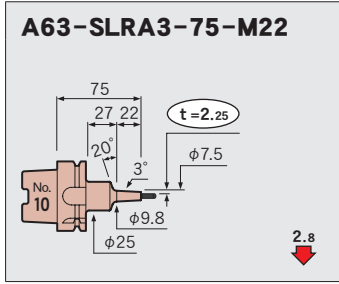
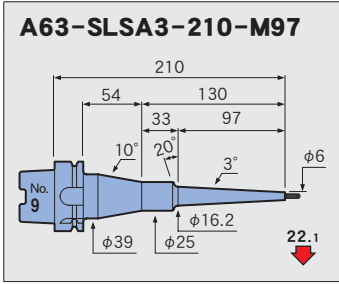

Feature
Shrink-fit Heater
MONO 3° MONO CURVE
MONO Series
2PIECE type
UNO
HYPER version
STRAIGHT arbor
OTHERS
PERIPHERALS
Technical information

φ 4

Feature
Shrink-fit Heater
MONO 3° MONO CURVE
MONO Series
2PIECE type
UNO
HYPER version
STRAIGHT anbor
OTHERS
PERIPHERALS
Technical Information

A63-SLSA4-95-M42

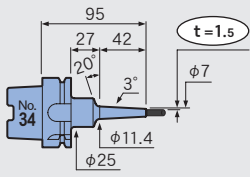

7.2

A63-SLSA4-125-M42

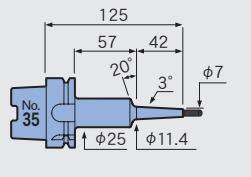

7.9

A63-SLSA4-155-M42

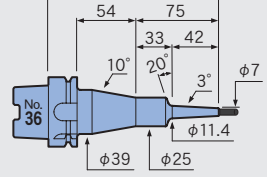

7.9

A63-SLSA4-120-M67

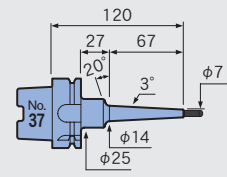

11.7

A63-SLSA4-150-M67

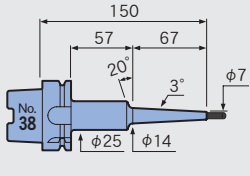

12.8

A63-SLSA4-180-M67

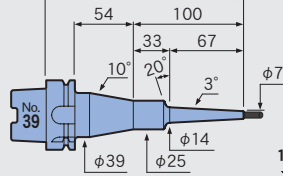

12.8

A63-SLSA4-150-M97

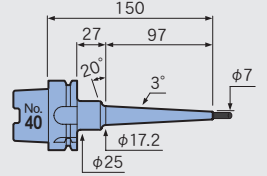

16.6

A63-SLSA4-180-M97

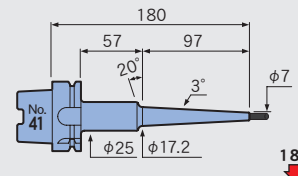

18.4

A63-SLSA4-210-M97

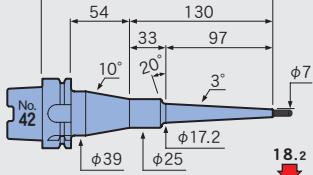

18.2

A63-SLRA4-75-M22

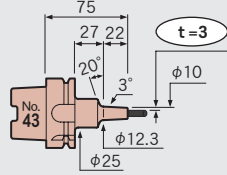

1.7

A63-SLRA4-105-M22

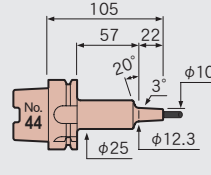

2.2

A63-SLRA4-135-M22

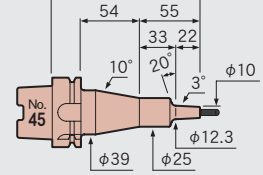

2.2

A63-SLRA4-95-M42

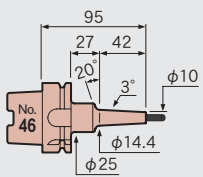

3.1

A63-SLRA4-125-M42

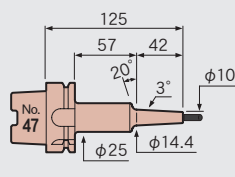

3.8

A63-SLRA4-155-M42

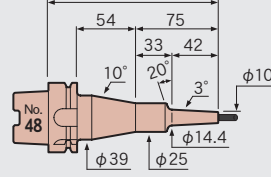

3.8

A63-SLRA4-120-M67

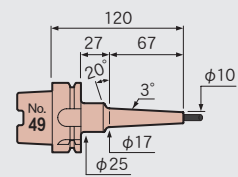

5.1

A63-SLRA4-150-M67

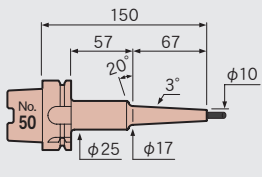

6.3

A63-SLRA4-180-M67

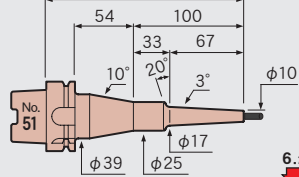

6.2

A63-SLRA4-150-M97

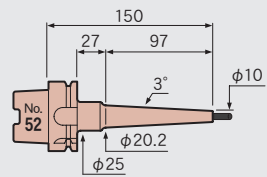

7.7

A63-SLRA4-180-M97

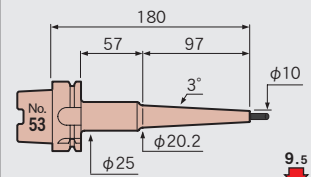

9.5

A63-SLRA4-210-M97

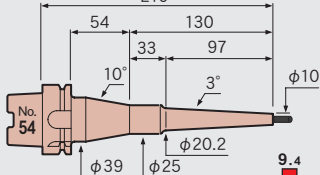

9.4

A63-SLRA4-180-M127

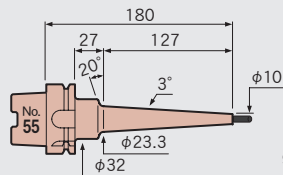

9.4

A63-SLRA4-210-M127

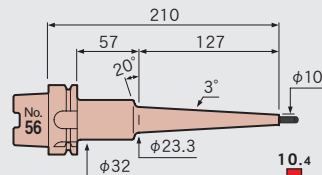

10.4

A63-SLRA4-240-M127

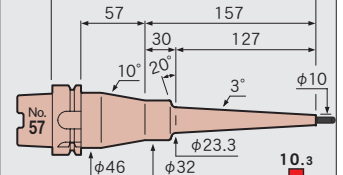

10.3

A63-SLFB4-75-M22

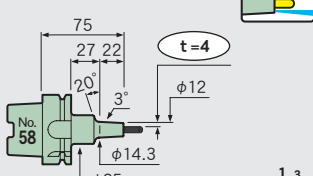

1.3

A63-SLFB4-105-M22

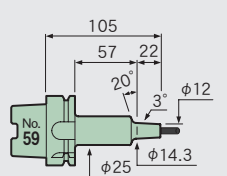

1.8

A63-SLFB4-135-M22

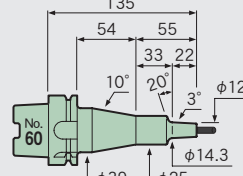

1.8

A63-SLFB4-95-M42

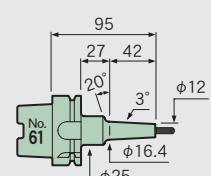

2.2

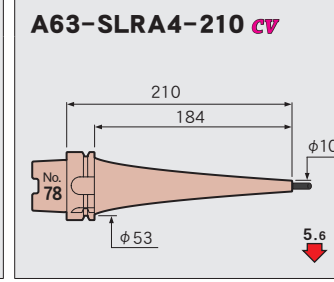
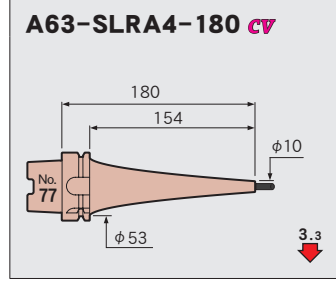
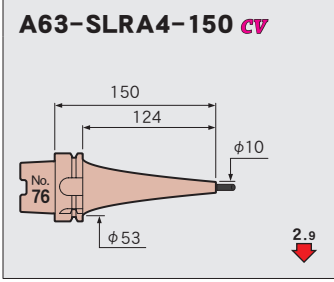
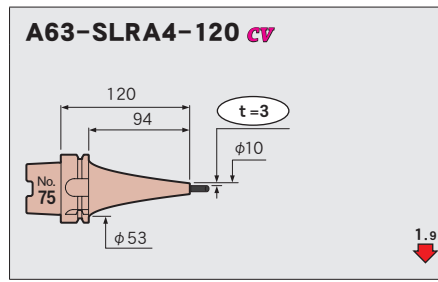
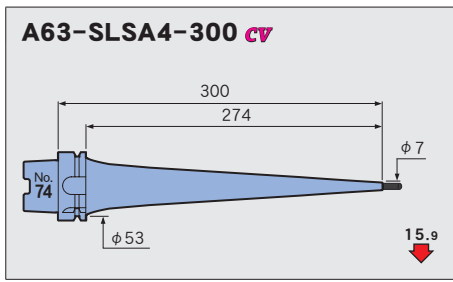
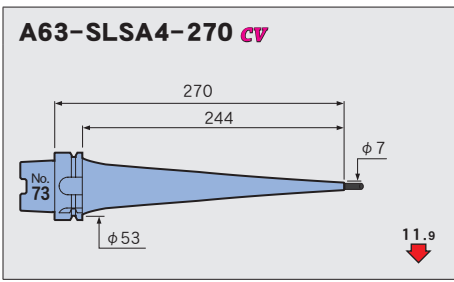
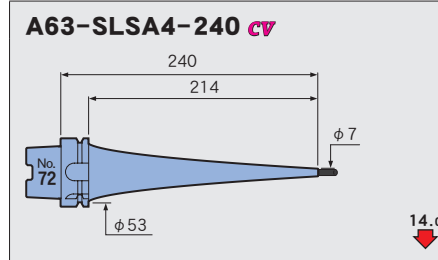
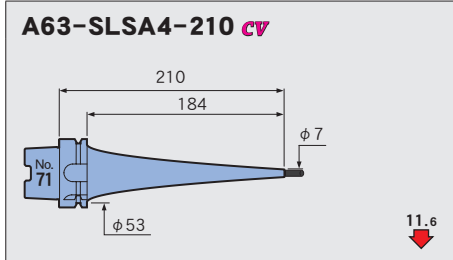
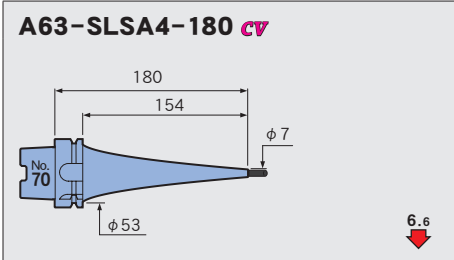
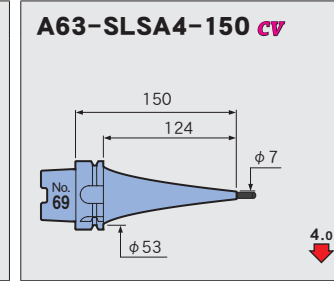
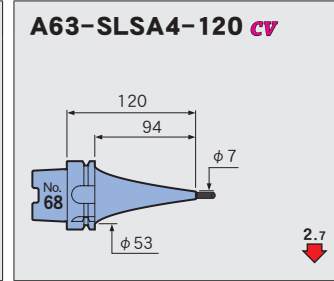
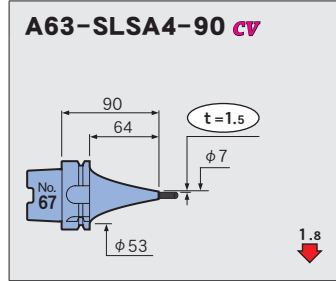
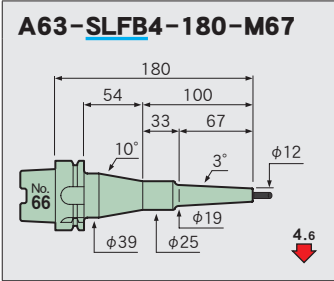
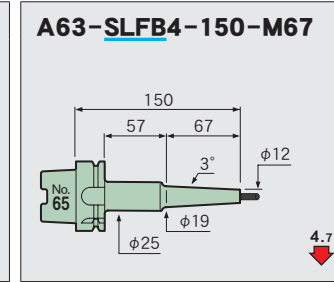
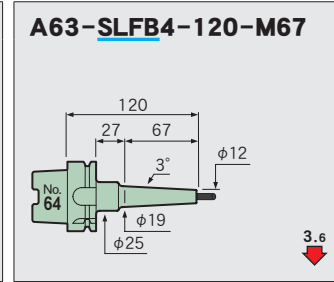
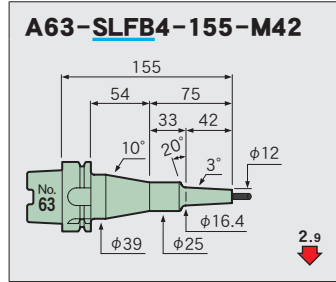
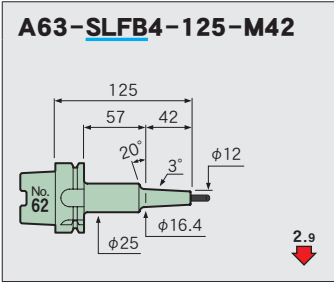

φ 3/16

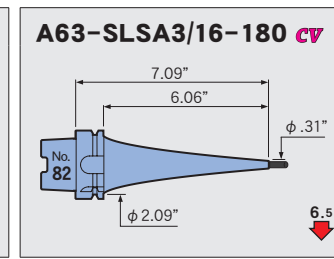
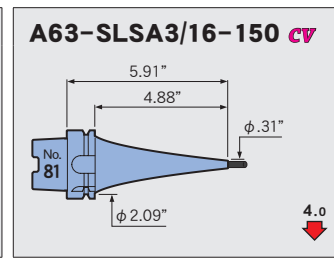
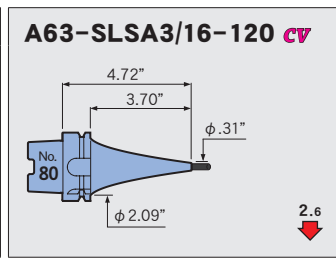
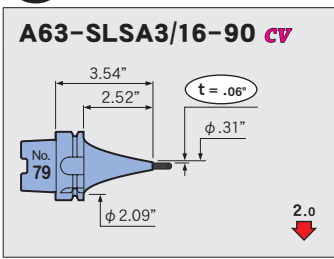

Feature
Shrink-fit Heater
MONO 3° MONO CURVE
MONO Series
2PIECE type
UNO
HYPER version
STRAIGHT anbor
OTHERS
PERIPHERALS
Technical Information

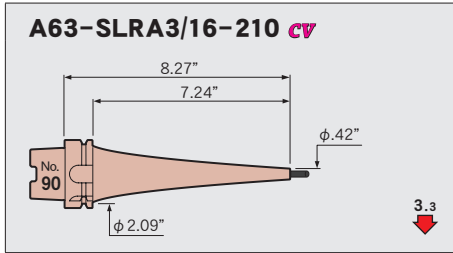
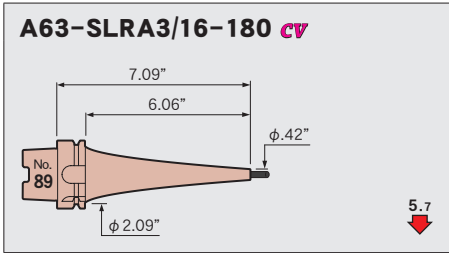
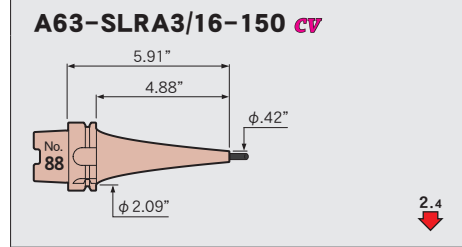
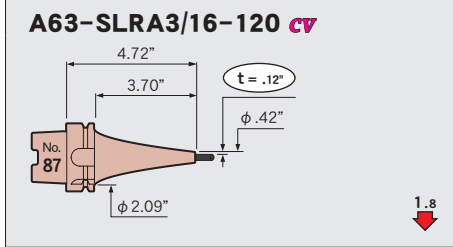
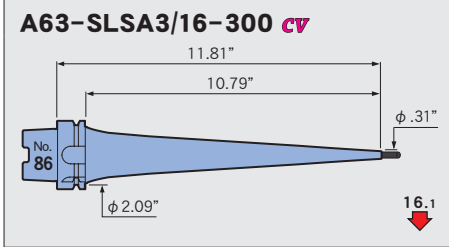
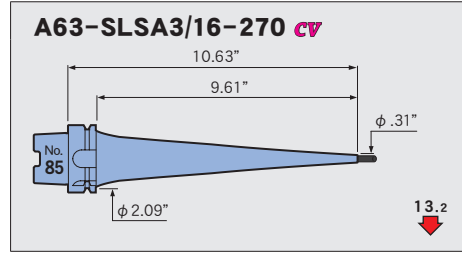
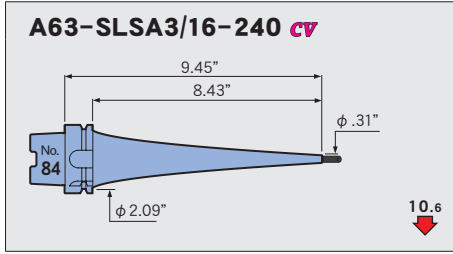
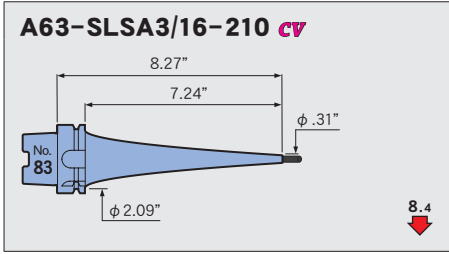

φ6

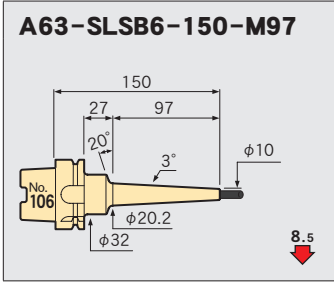
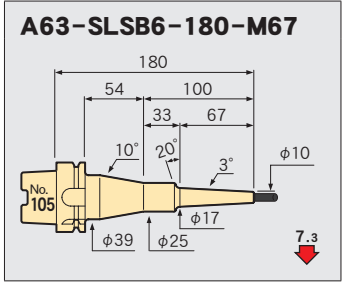
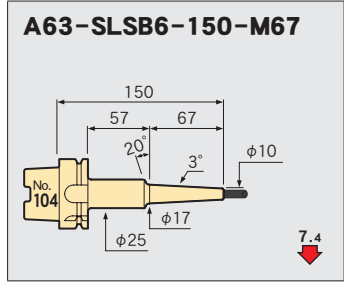
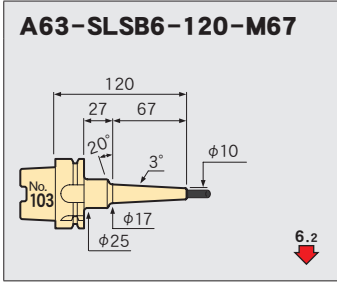
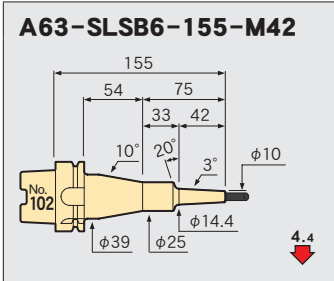
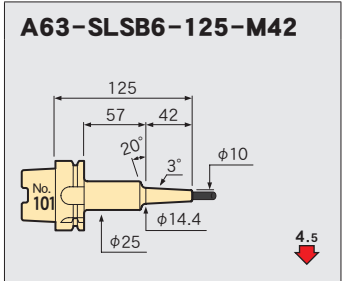
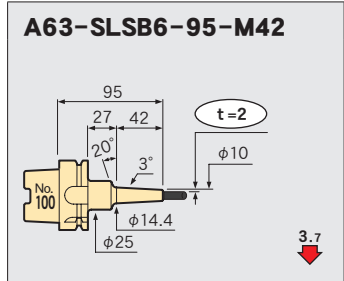
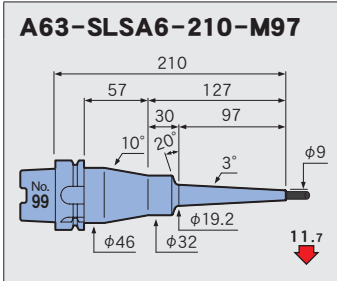
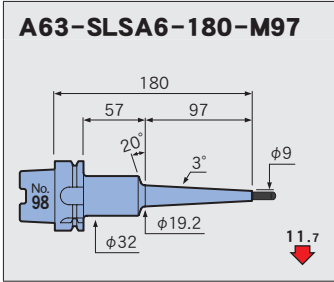
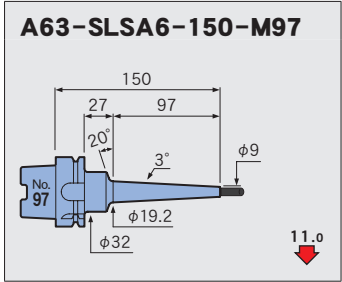
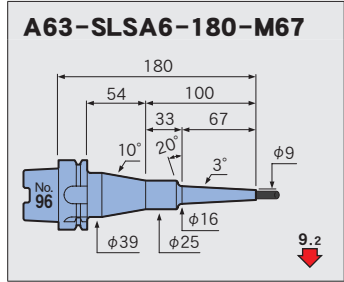
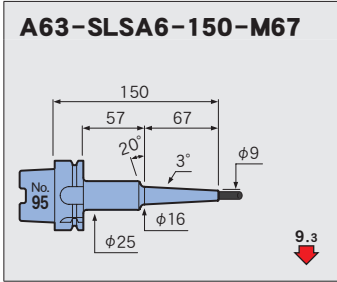
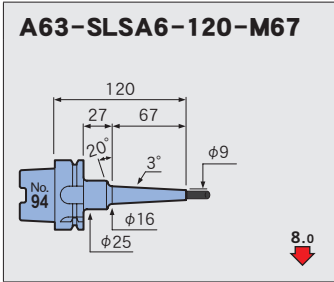
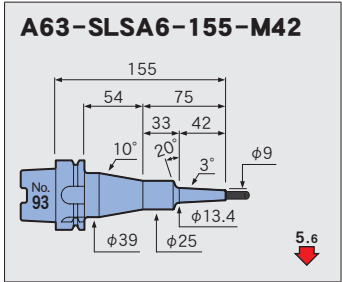
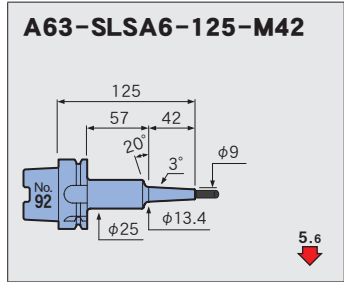
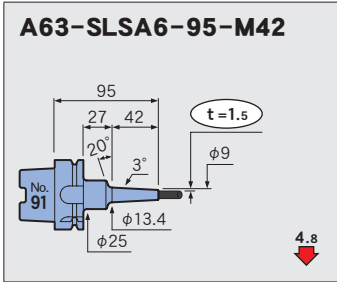

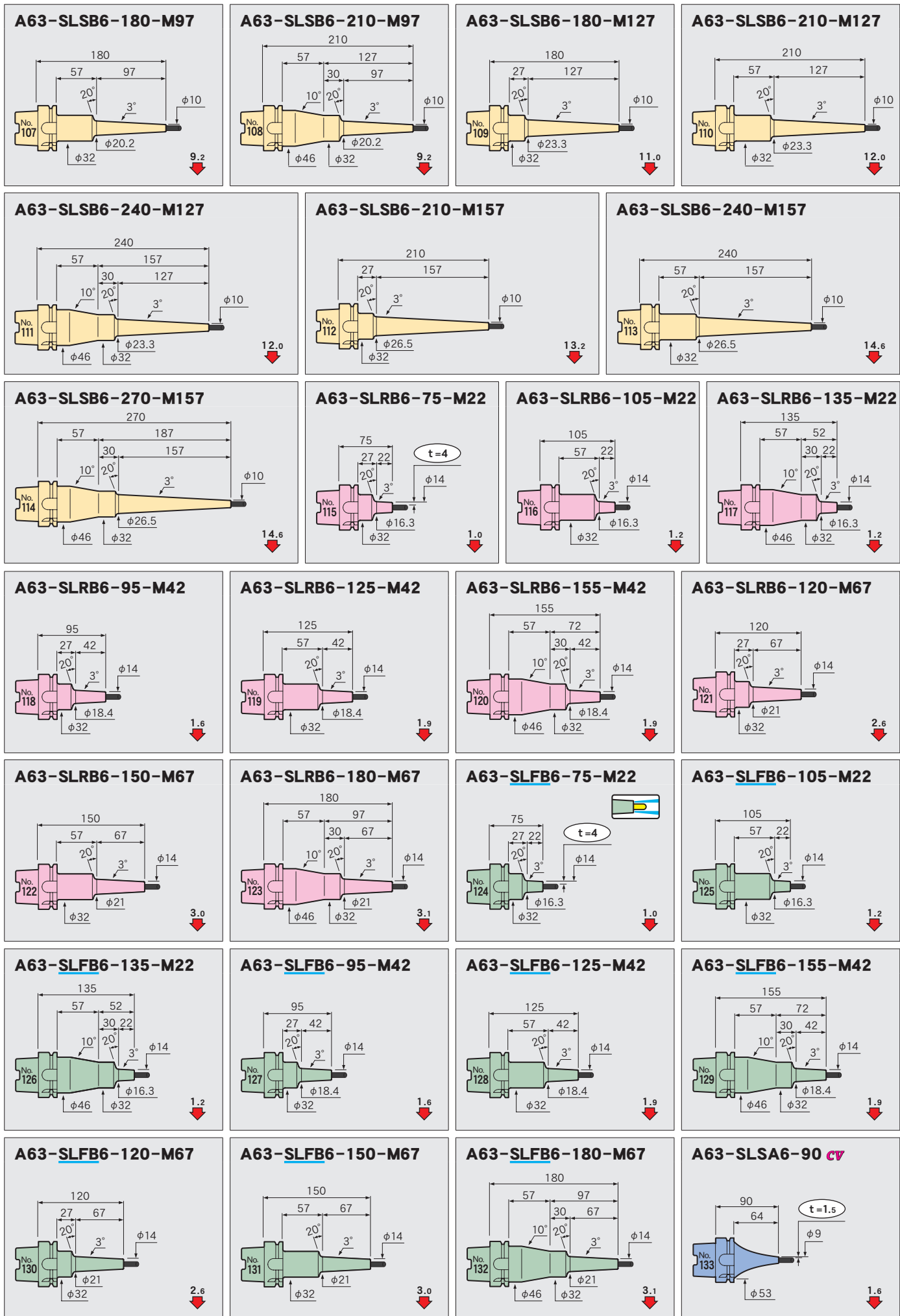

Feature
Shrink-fit Heater

MONO 3°
MONO CURVE

MONO Series

2PIECE type

UNO
HYPER version

STRAIGHT
airbor

OTHERS

PERIPHERALS

Technical
Information

Feature
Shrink-fit Heater
MONO 3° MONO CURVE
MONO Series
2PIECE type
UNO
HYPER version
STRAIGHT arbor
OTHERS
PERIPHERALS
Technical Information

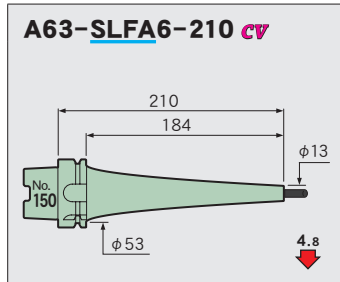
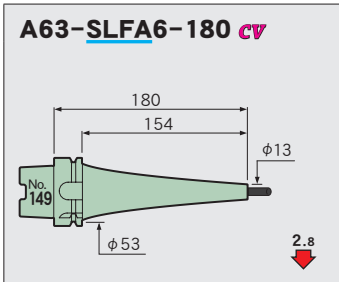
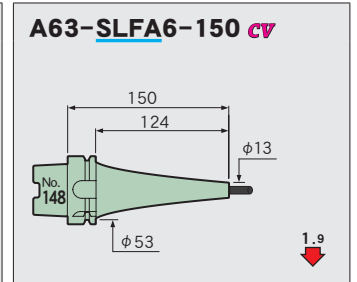
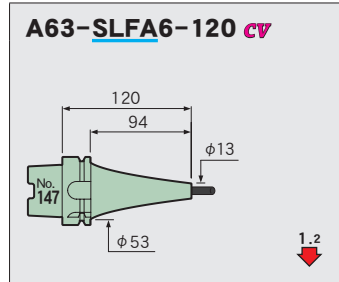
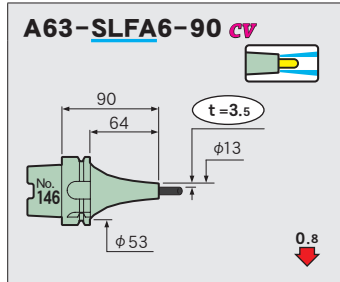
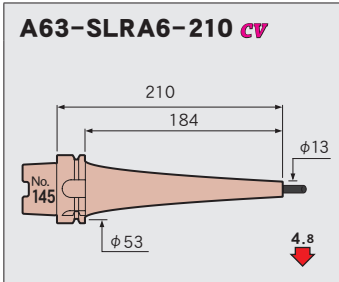
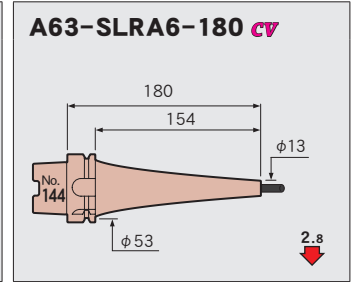
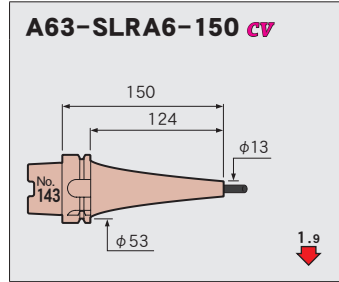
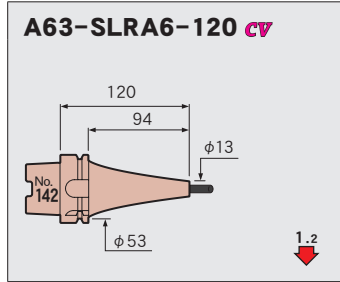
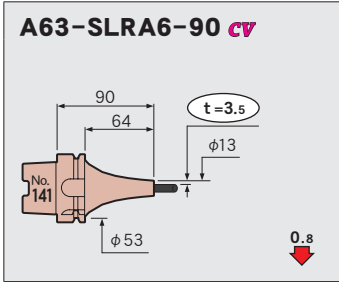
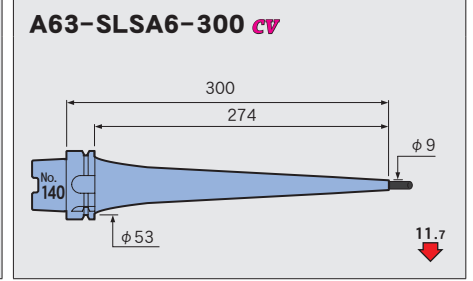
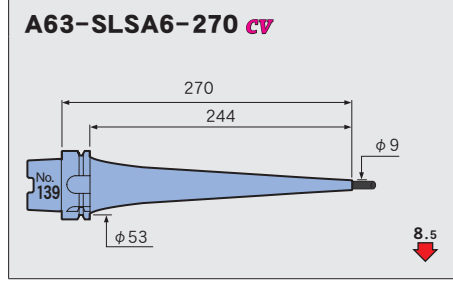
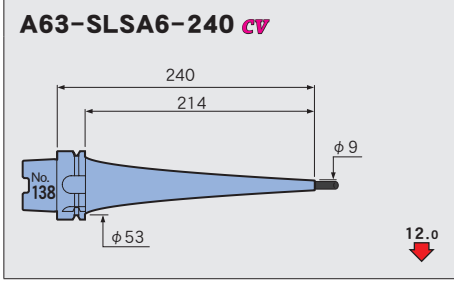
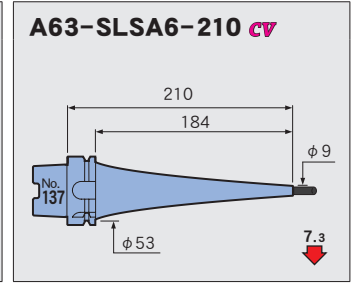
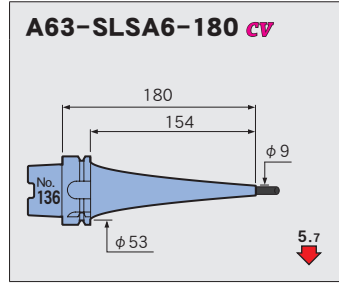
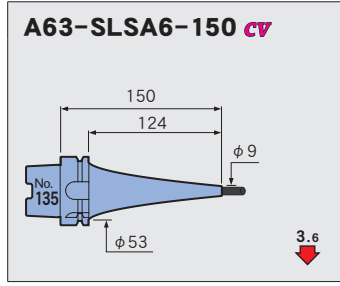
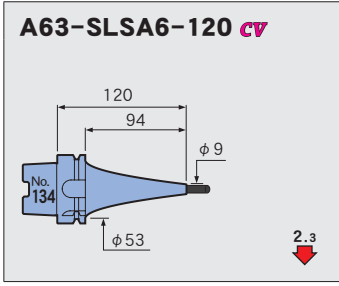

$\phi 1/4$

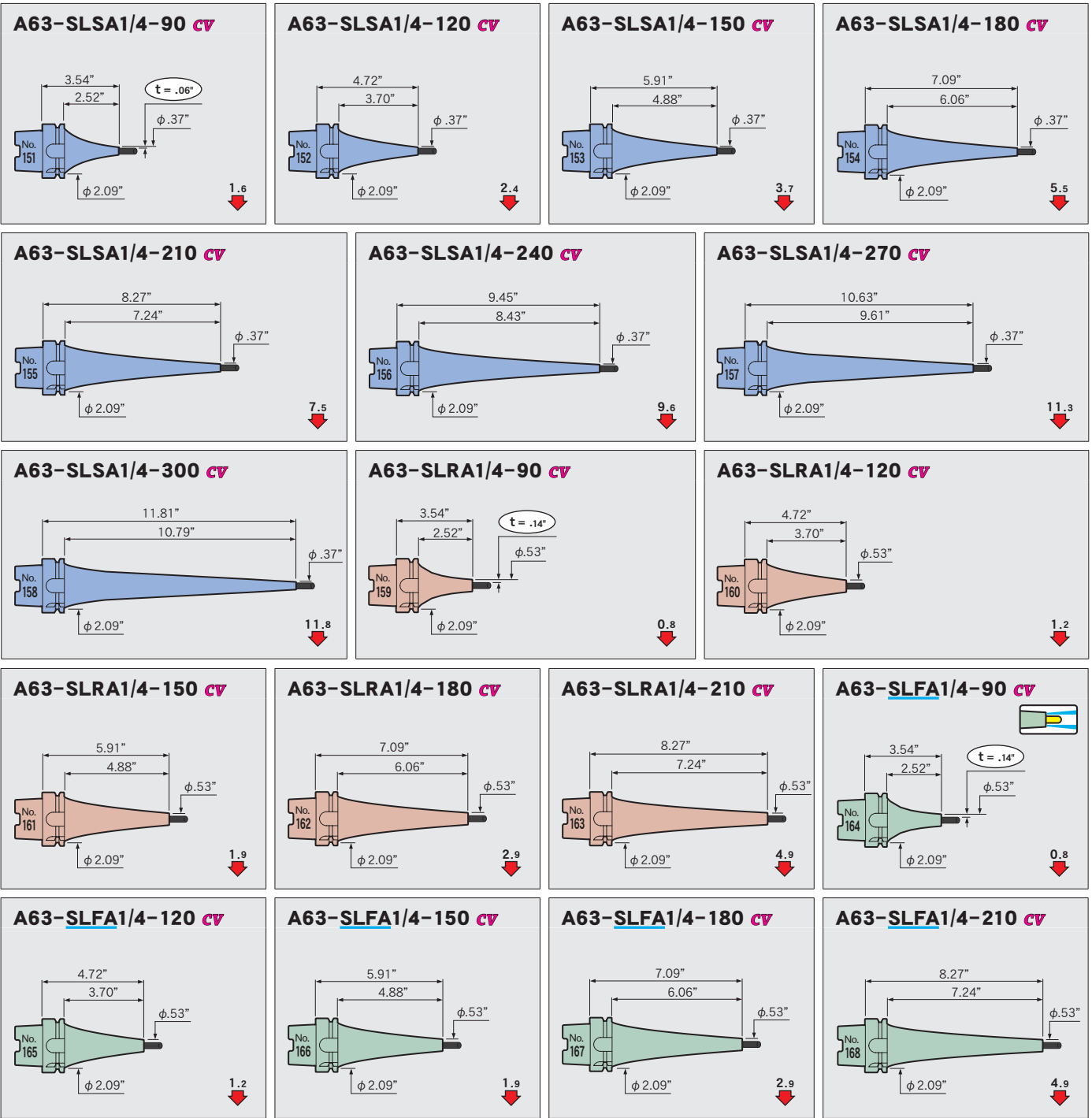

Feature

Shrink-fit Heater

MONO 3°
MONO CURVE

MONO Series

2PIECE type

UNO

HYPER
version

STRAIGHT
arbor

OTHERS

PERIPHERALS

Technical
information

A63-SLSA8-95-M42

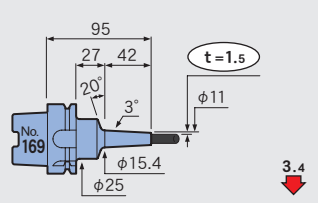

A63-SLSA8-125-M42

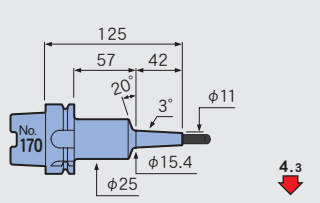

A63-SLSA8-155-M42

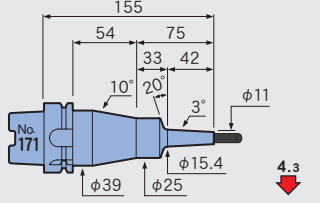

A63-SLSA8-120-M67

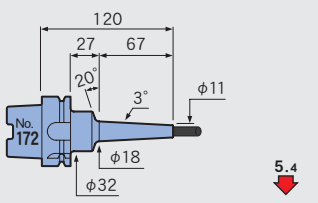

A63-SLSA8-150-M67

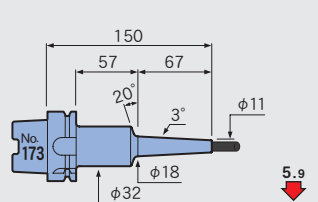

A63-SLSA8-180-M67

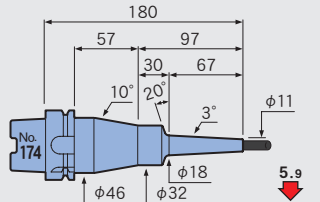

A63-SLSA8-150-M97

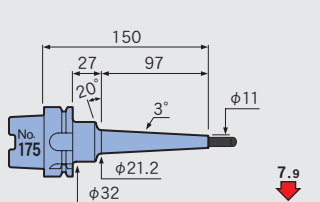

A63-SLSA8-180-M97

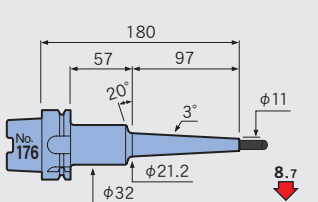

A63-SLSA8-210-M97

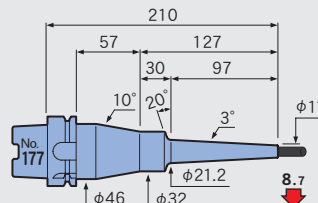

A63-SLSB8-95-M42

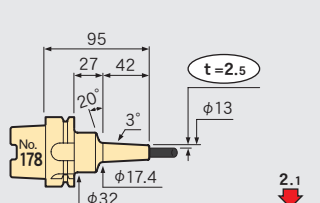

A63-SLSB8-125-M42

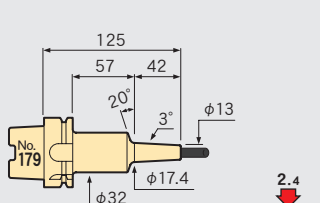

A63-SLSB8-155-M42

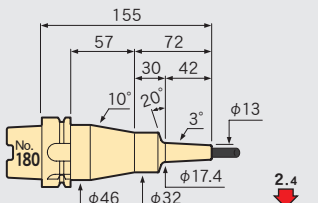

A63-SLSB8-120-M67

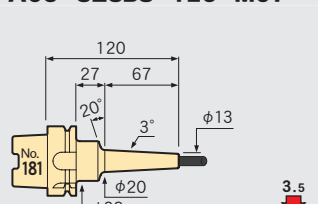

A63-SLSB8-150-M67

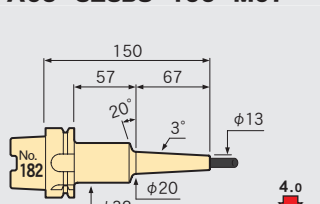

A63-SLSB8-180-M67

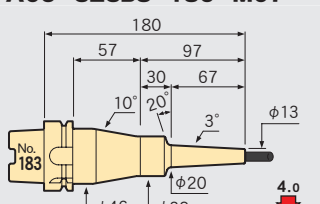

A63-SLSB8-150-M97

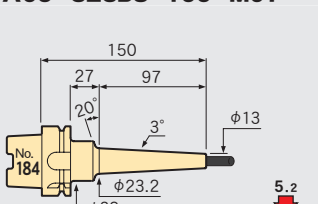

A63-SLSB8-180-M97

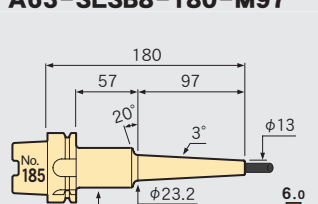

A63-SLSB8-210-M97

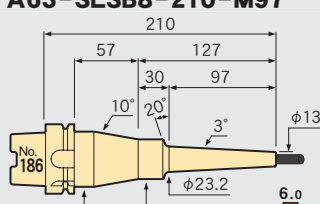

A63-SLSB8-180-M127

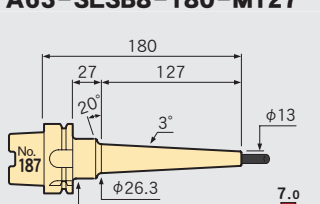

A63-SLSB8-210-M127

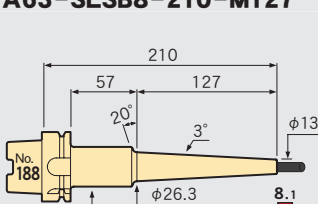

A63-SLSB8-240-M127

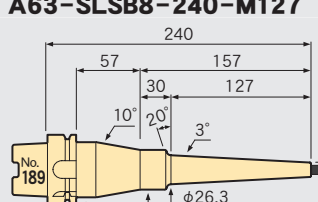

A63-SLSB8-210-M157

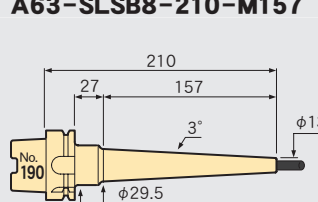

A63-SLSB8-240-M157

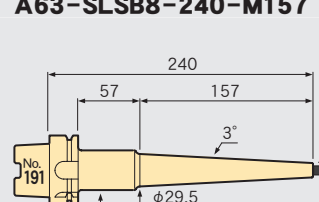

A63-SLSB8-270-M157

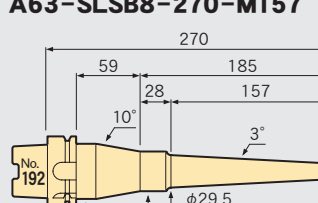

A63-SLRB8-75-M22

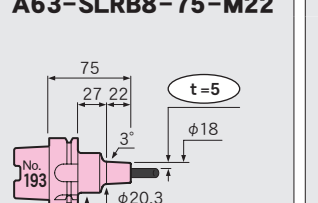

A63-SLRB8-105-M22

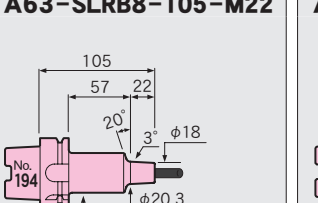

A63-SLRB8-135-M22

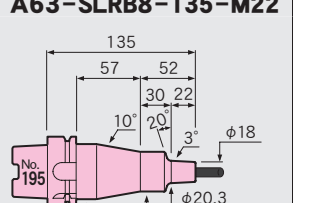

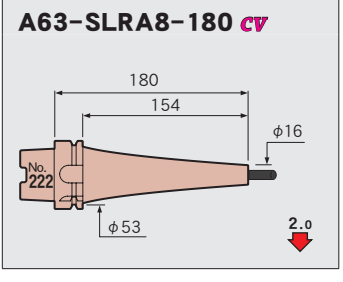
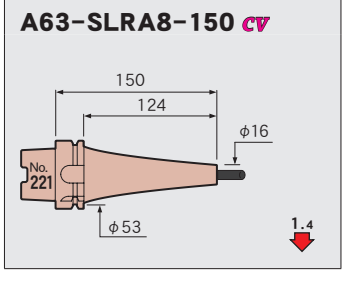
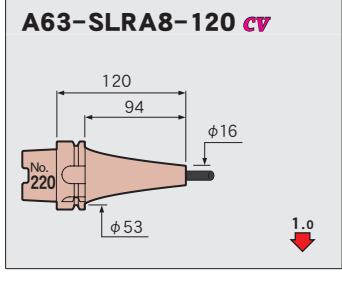
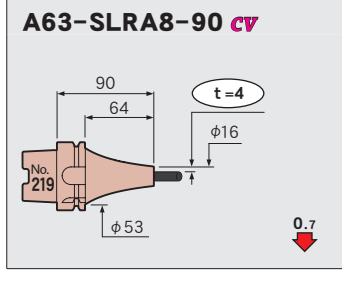
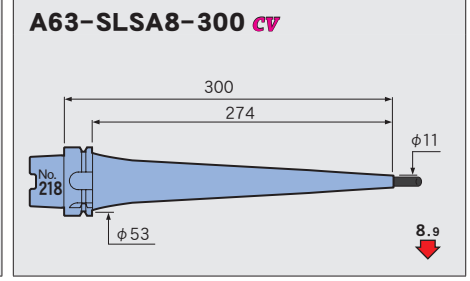
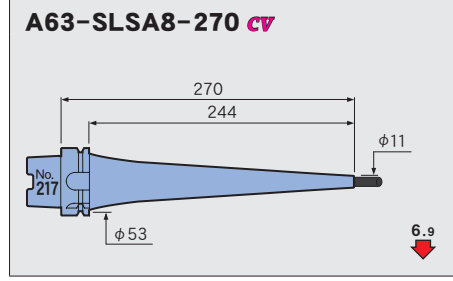
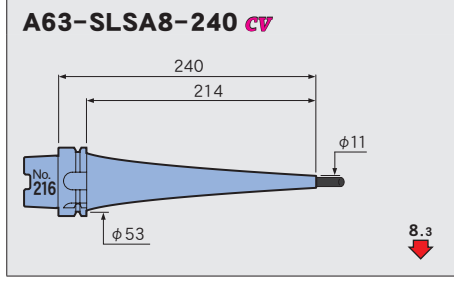
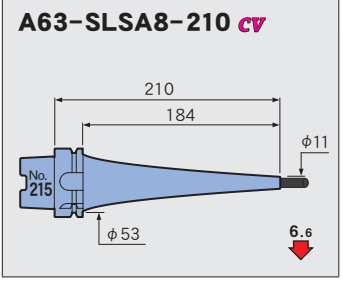
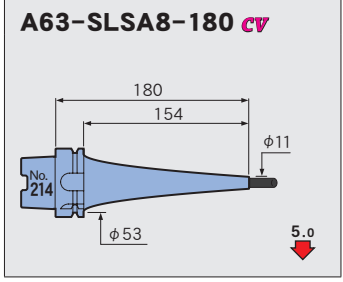
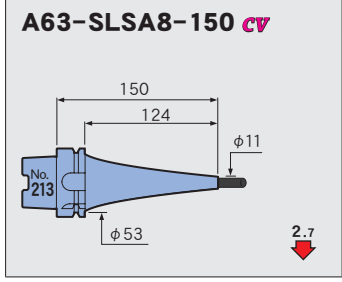
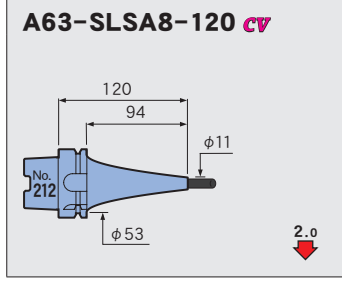
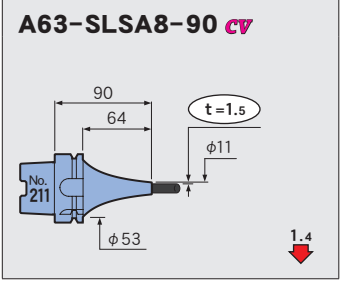
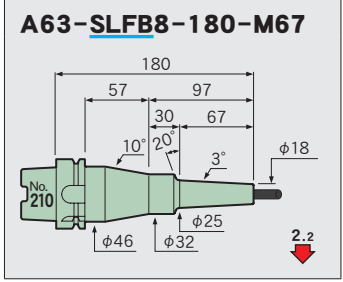
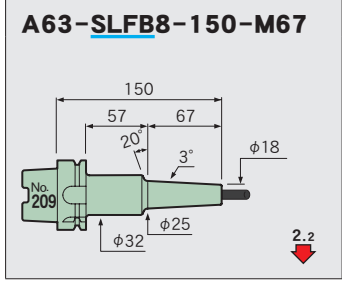
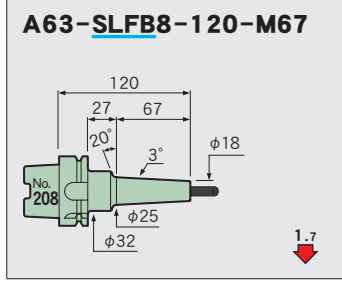
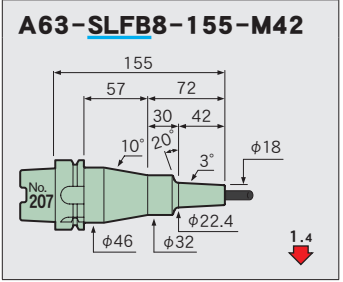
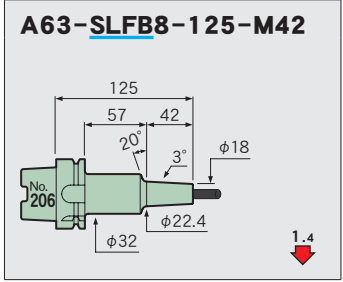
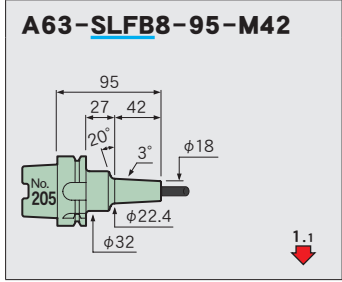
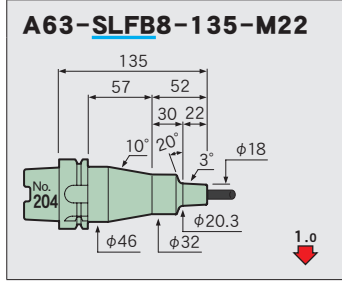
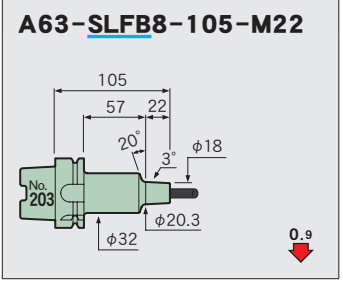
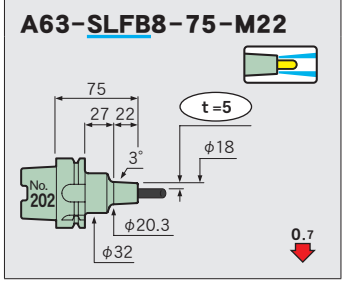
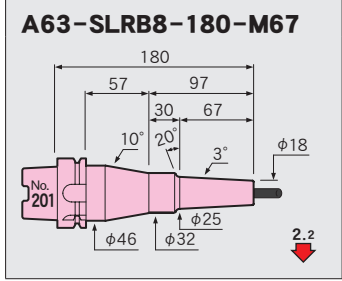
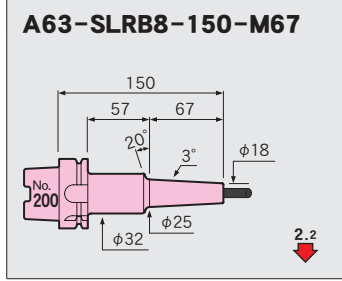
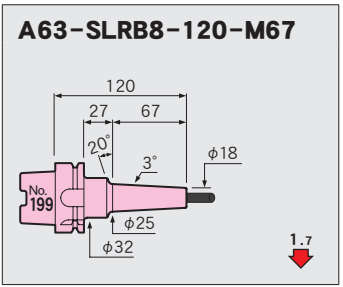
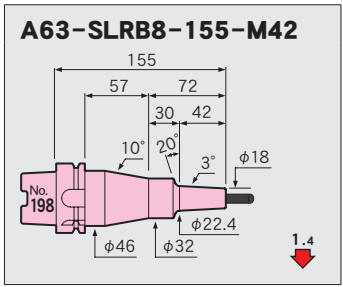
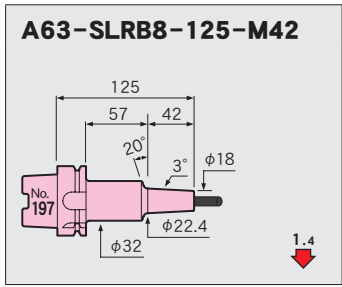
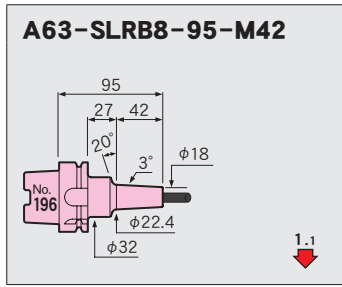

Feature
Shrink-fit Heater
MONO 3° MONO CURVE
MONO Series
2PIECE type
UNO
HYPER version
STRAIGHT anbor
OTHERS
PERIPHERALS
Technical Information

Feature
Shrink-fit Heater
MONO 3° MONO CURVE
MONO Series
2PIECE type
UNO
HYPER version
STRAIGHT anbor
OTHERS
PERIPHERALS
Technical Information

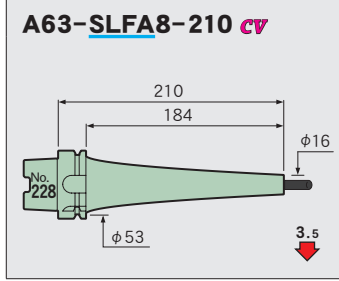
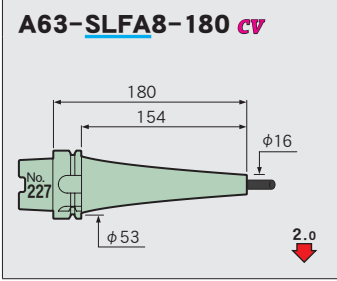
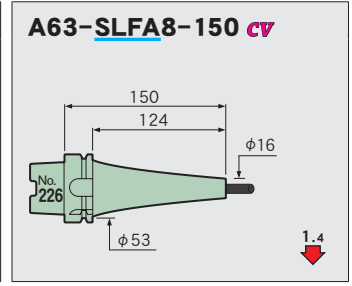
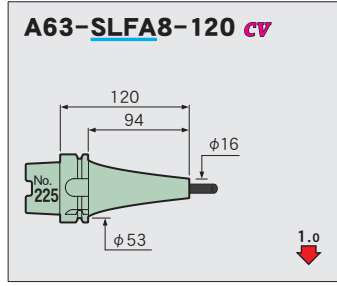
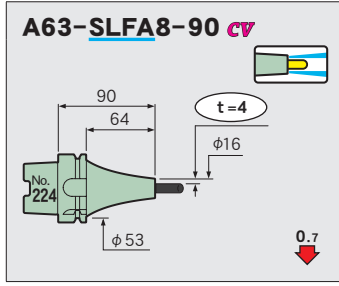
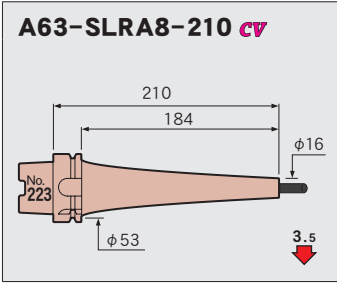

$\phi 5/16$

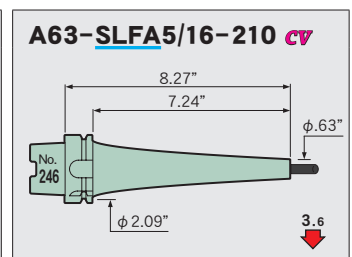
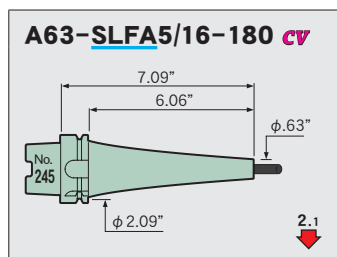
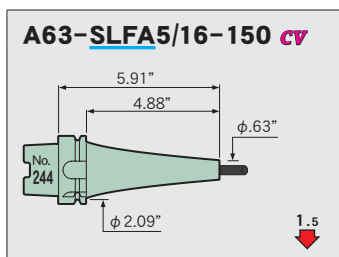
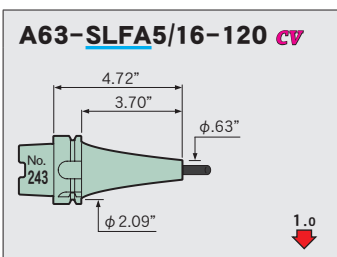
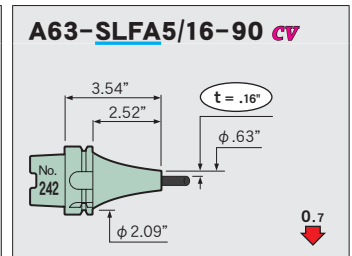
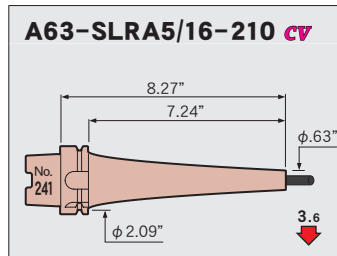
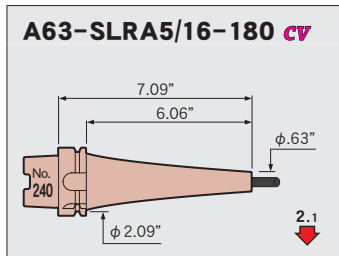
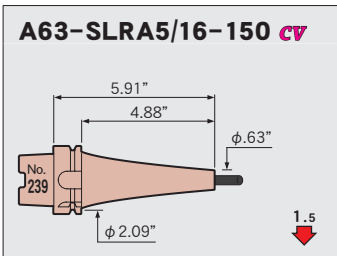
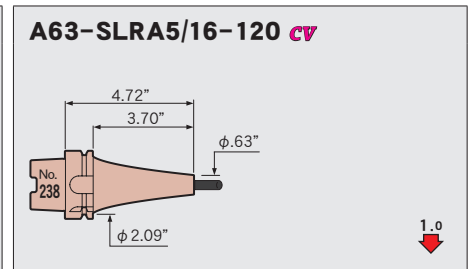
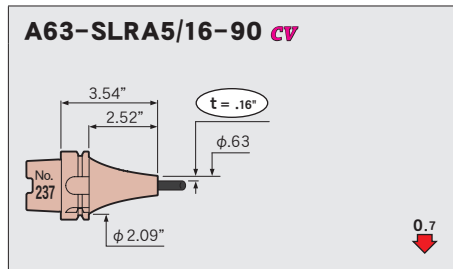
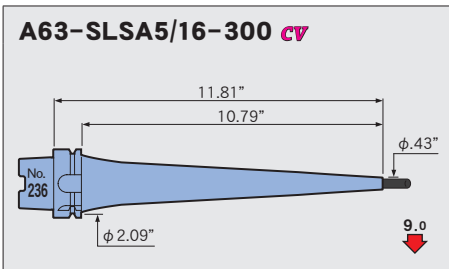
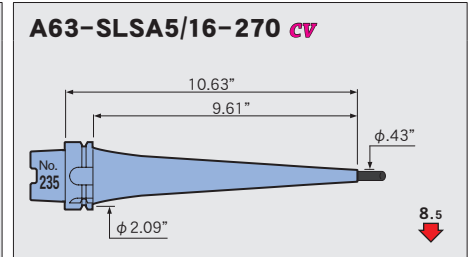
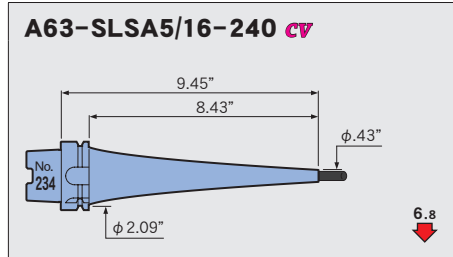
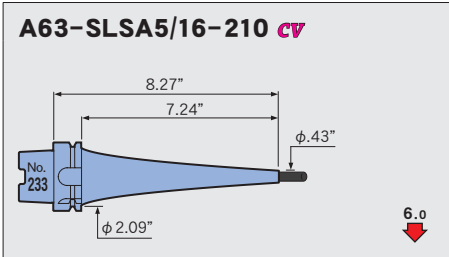
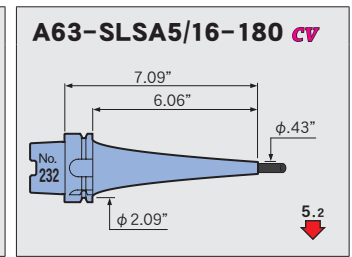
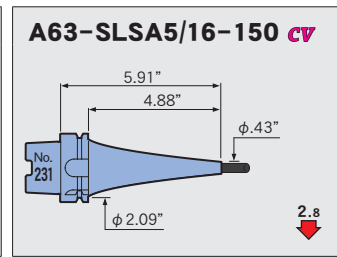
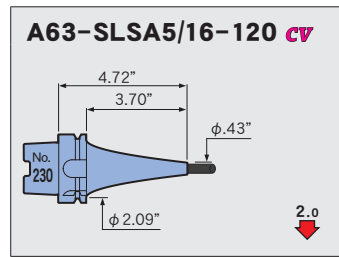
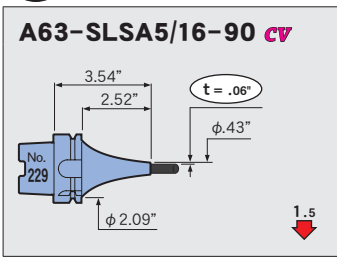

φ10

A63-SLSA10-95-M42

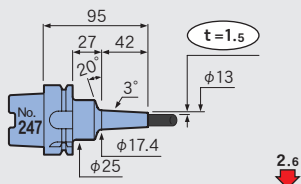

A63-SLSA10-125-M42

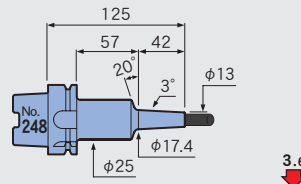

A63-SLSA10-155-M42

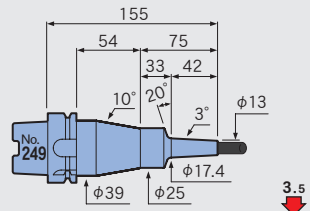

A63-SLSA10-120-M67

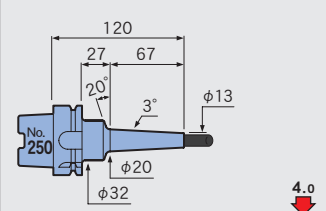

A63-SLSA10-150-M67

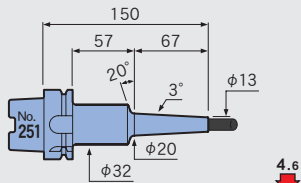

A63-SLSA10-180-M67

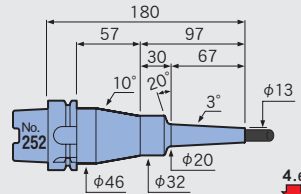

A63-SLSA10-150-M97

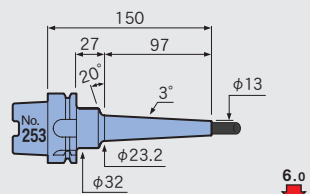

A63-SLSA10-180-M97

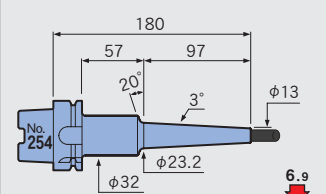

A63-SLSA10-210-M97

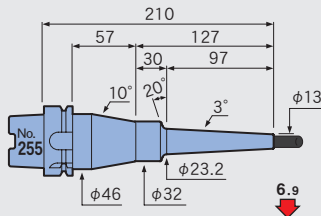

A63-SLSB10-95-M42

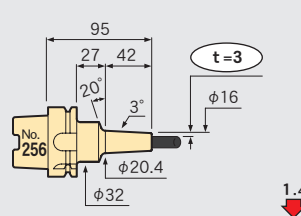

A63-SLSB10-125-M42

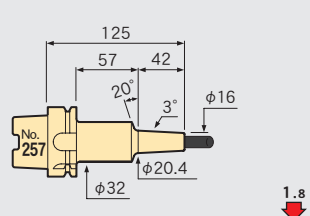

A63-SLSB10-155-M42

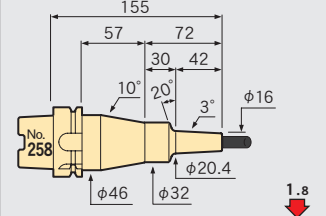

A63-SLSB10-120-M67

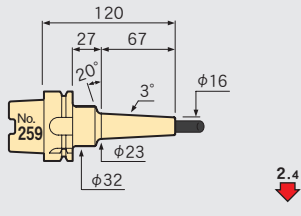

A63-SLSB10-150-M67

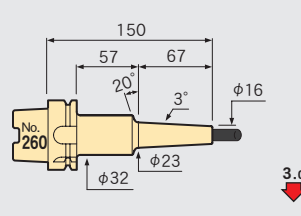

A63-SLSB10-180-M67

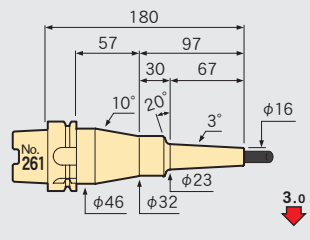

A63-SLSB10-150-M97

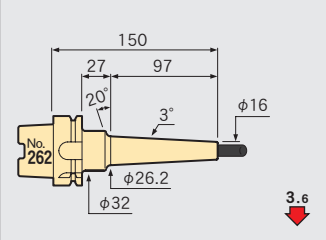

A63-SLSB10-180-M97

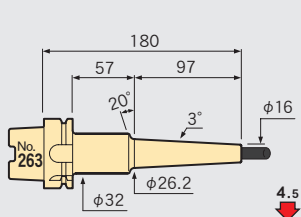

A63-SLSB10-210-M97

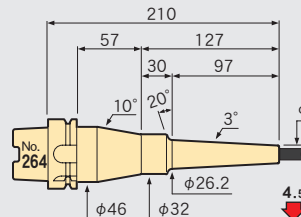

A63-SLSB10-180-M127

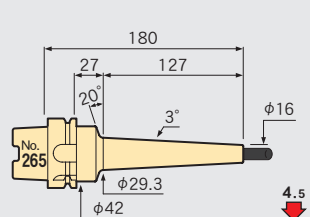

A63-SLSB10-210-M127

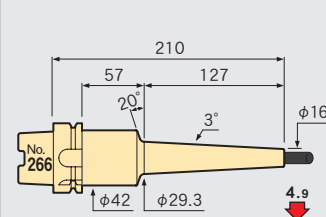

A63-SLSB10-240-M127

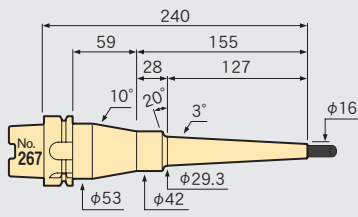

A63-SLSB10-210-M157

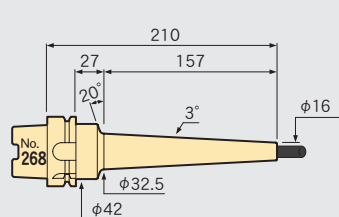

A63-SLSB10-240-M157

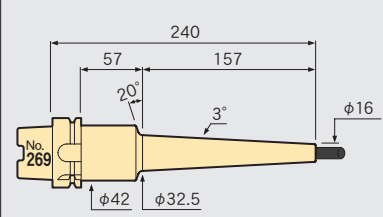

Feature

Shrink-fit Heater

MONO 3°
MONO CURVE

MONO Series

2PIECE type

UNO

HYPER
version

STRAIGHT
arbor

OTHERS

PERIPHERALS

Technical
information

Feature
Shrink-fit Heater
MONO 3° MONO CURVE
MONO Series
2PIECE type
UNO
HYPER version
STRAIGHT anbor
OTHERS
PERIPHERALS
Technical Information

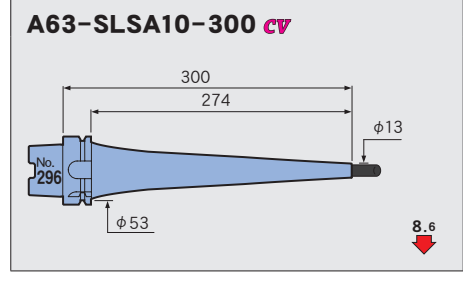
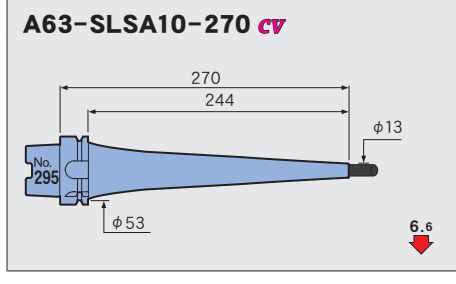
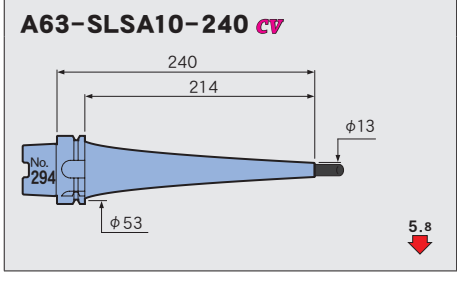
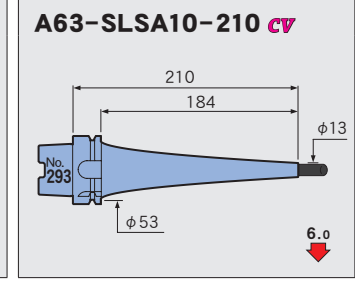
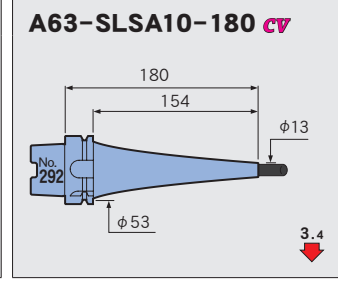
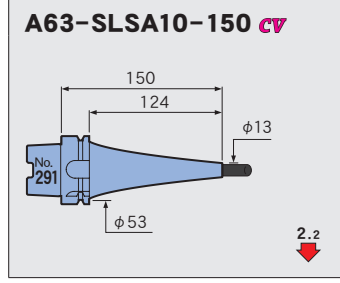
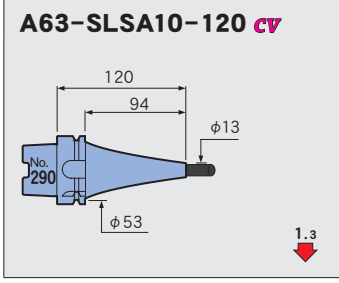
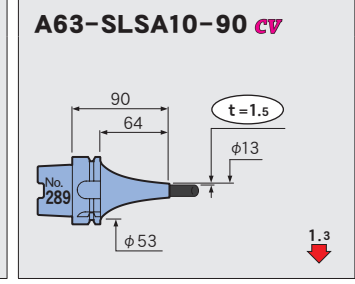
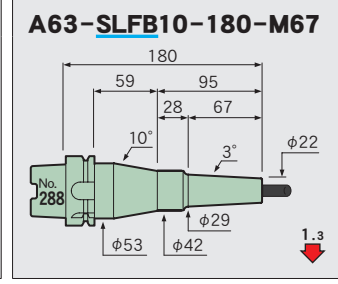
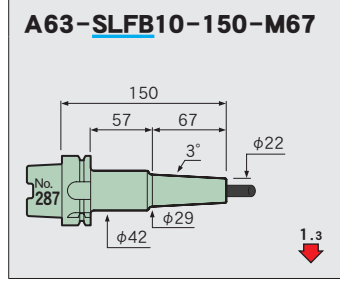
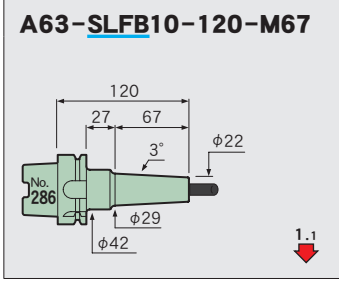
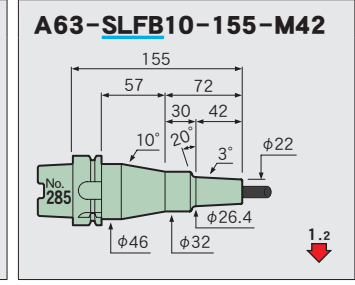
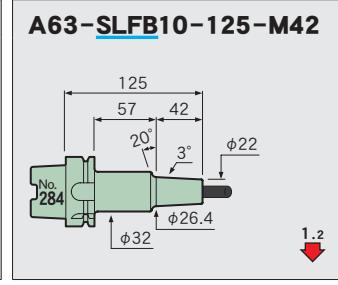
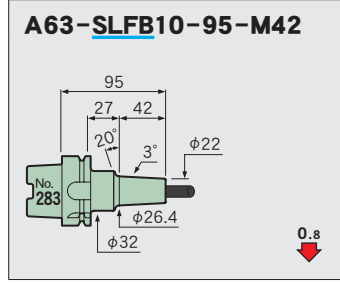
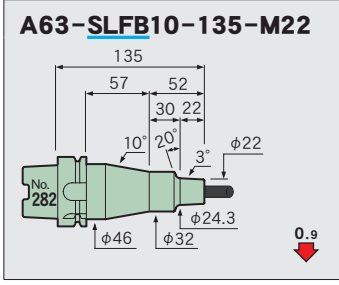
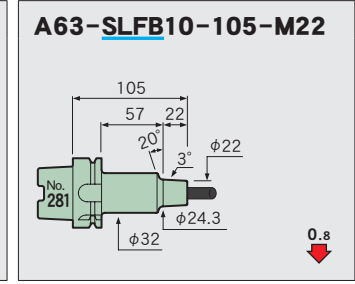
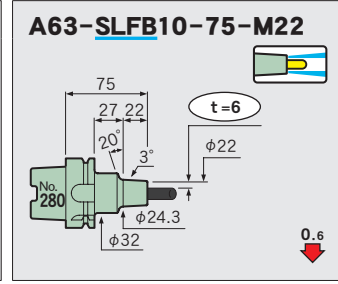
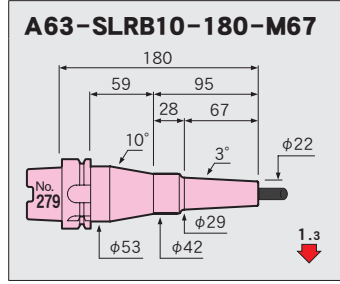
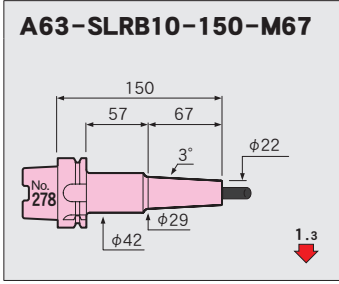
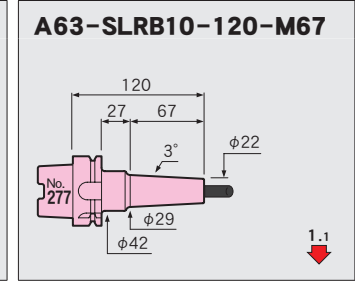
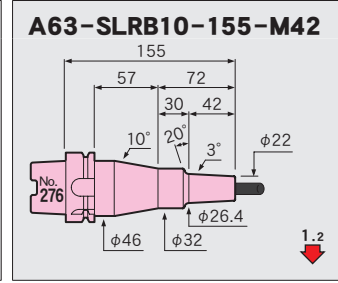
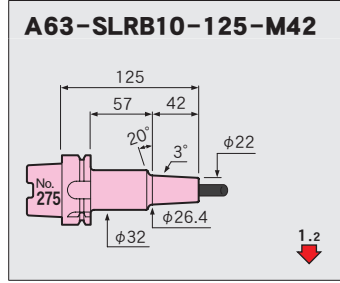
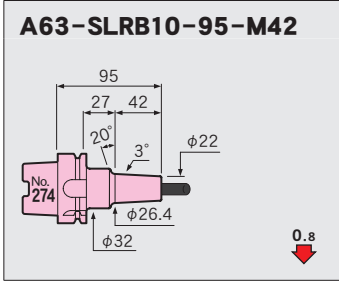
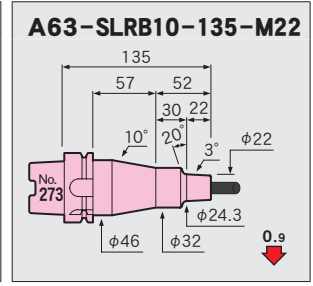
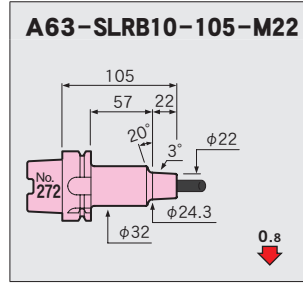
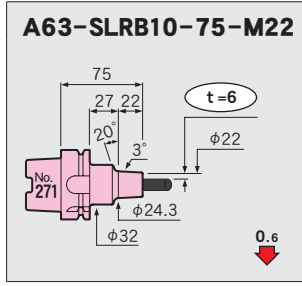
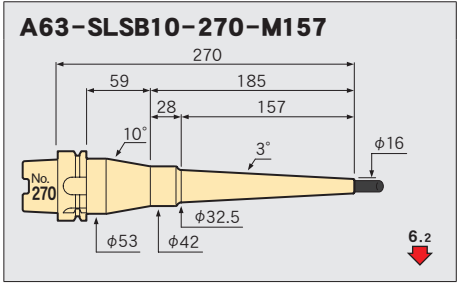

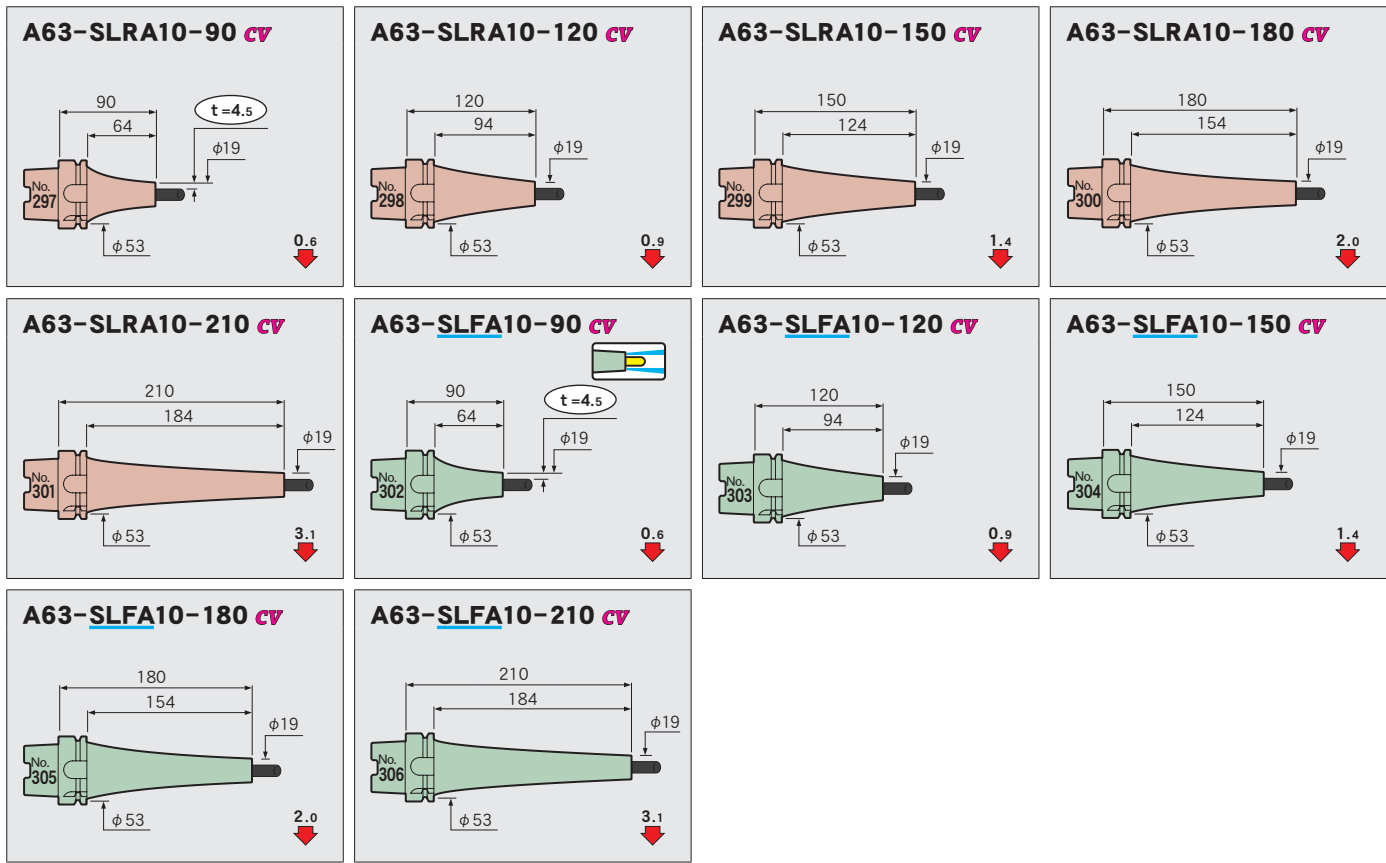

φ 3/8

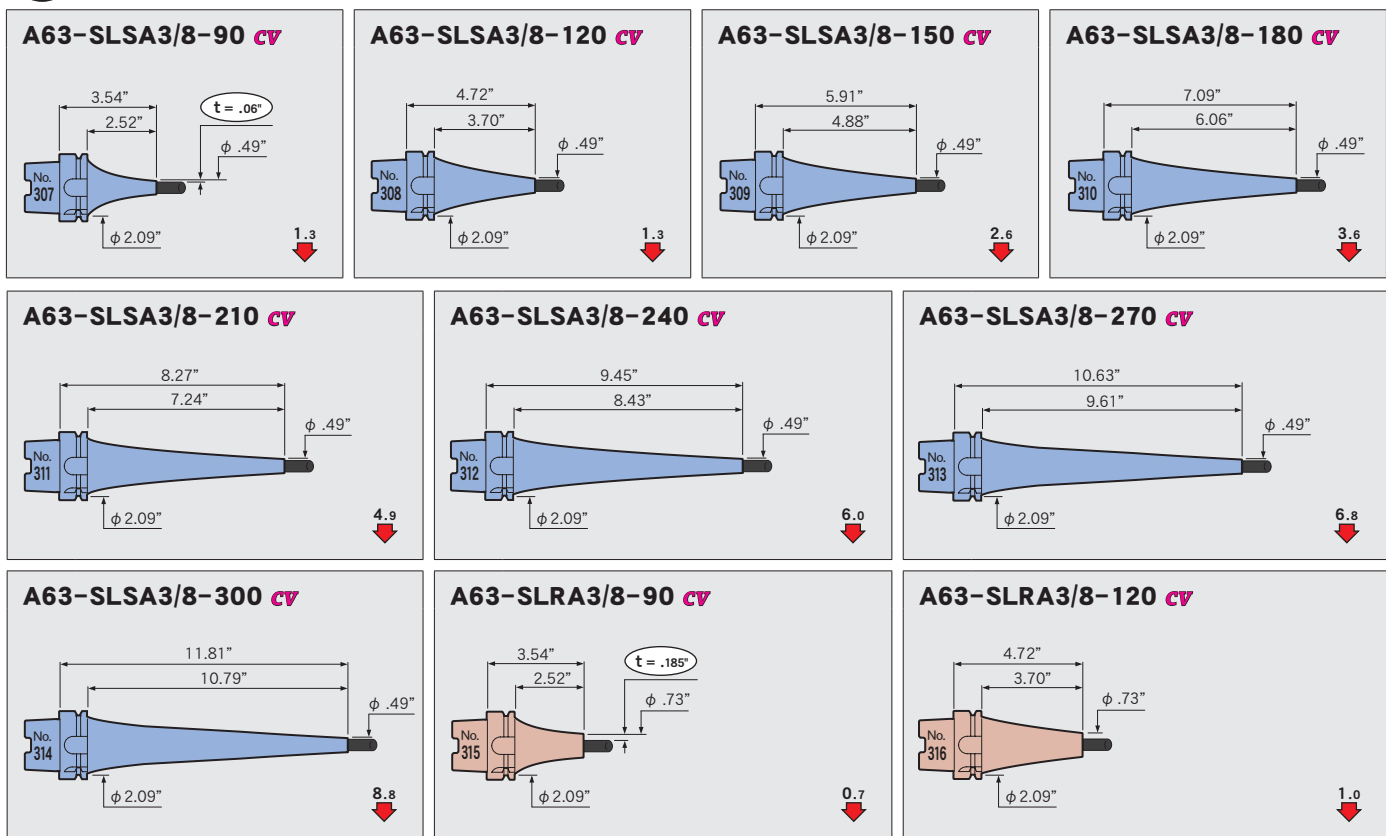

Feature
Shrink-fit Heater
MONO 3° MONO CURVE
MONO Series
2PIECE type
UNO
HYPER version
STRAIGHT anbor
OTHERS
PERIPHERALS
Technical Information

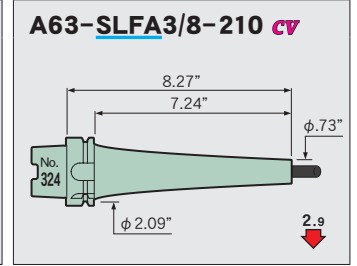
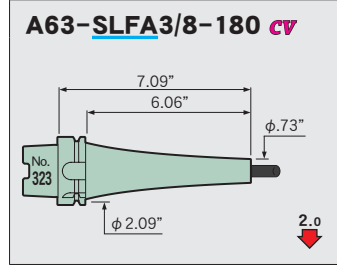
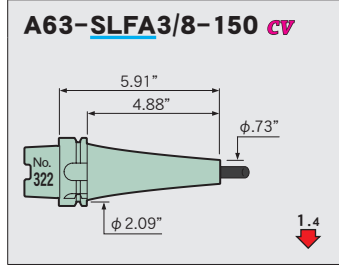
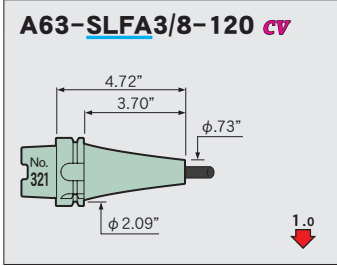
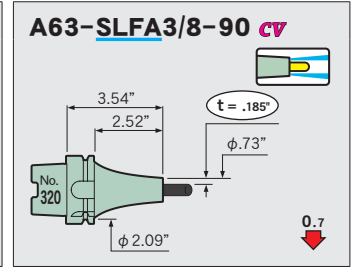
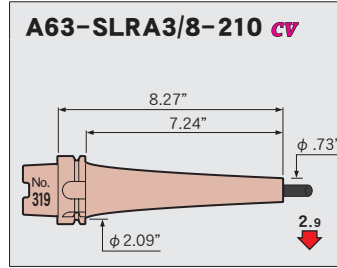
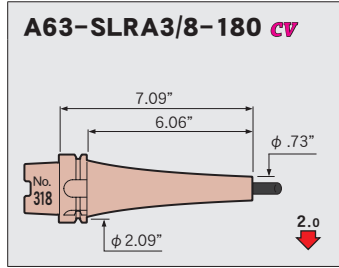
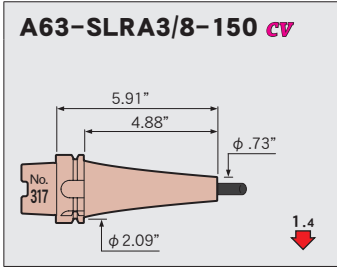

φ 12

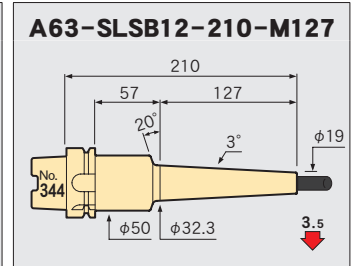
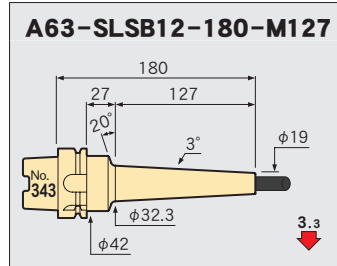
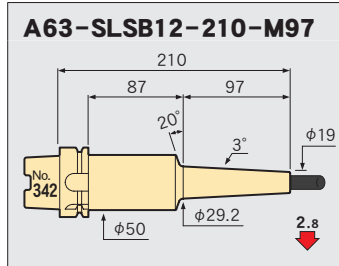
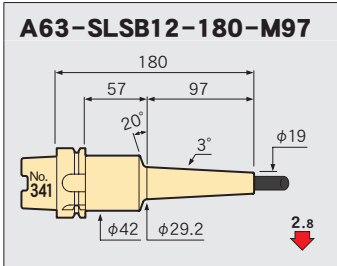
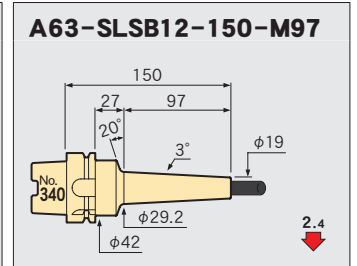
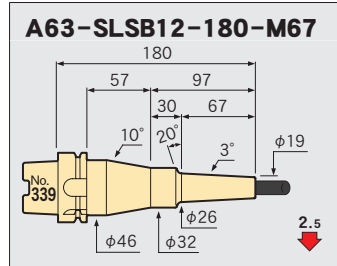
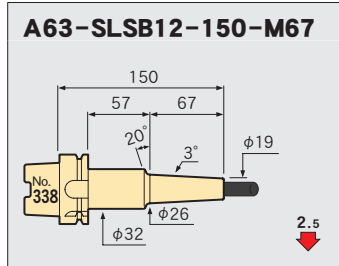
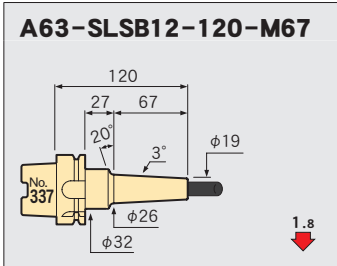
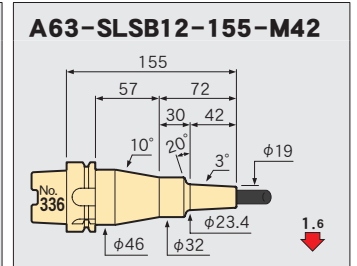
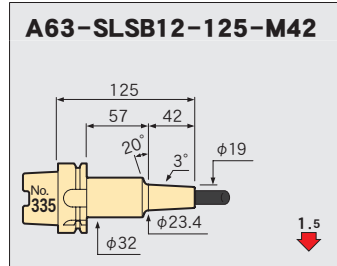
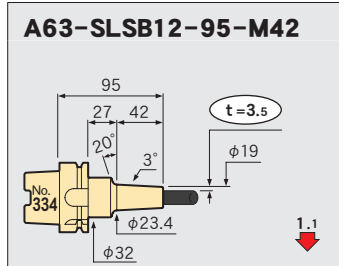
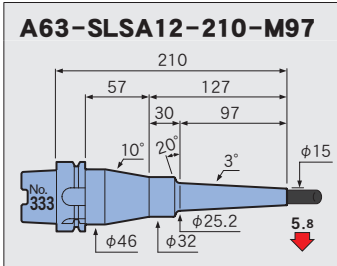
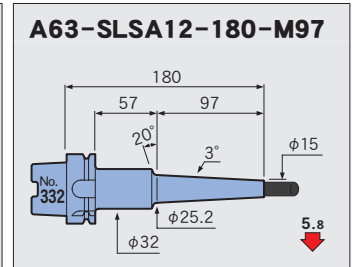
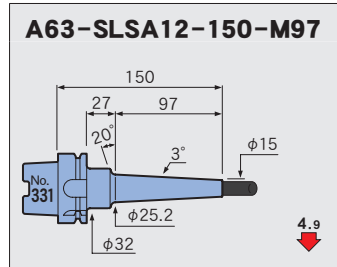
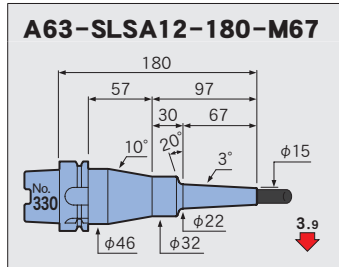
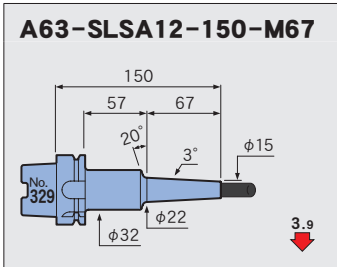
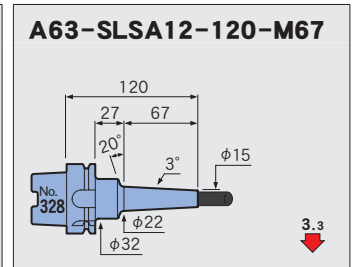
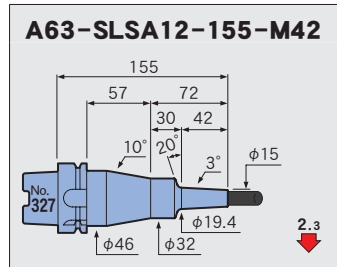
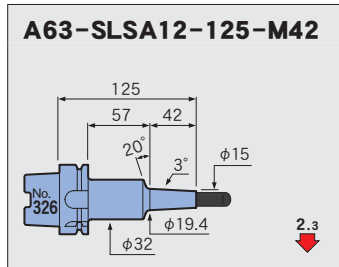
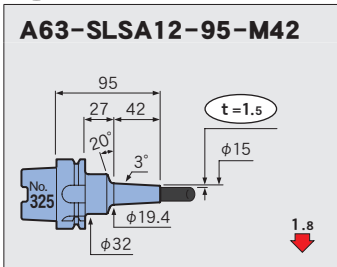

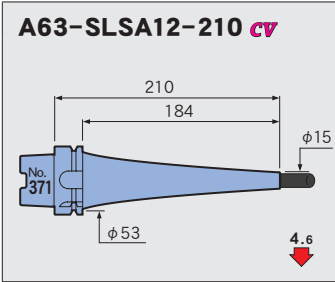
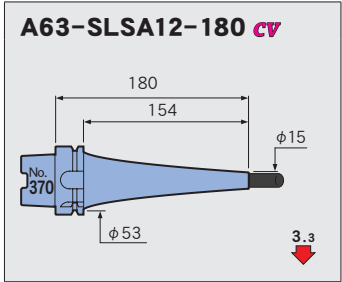
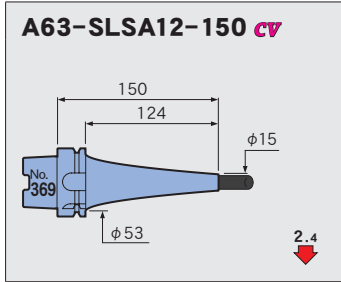
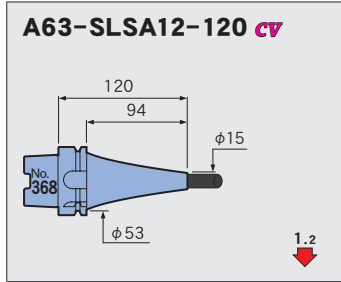
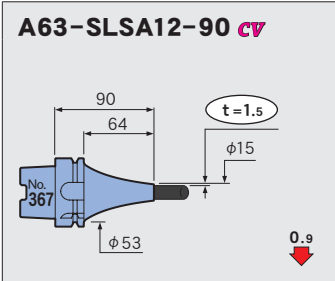
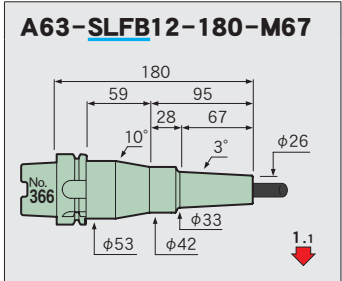
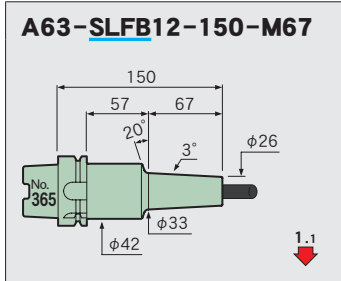
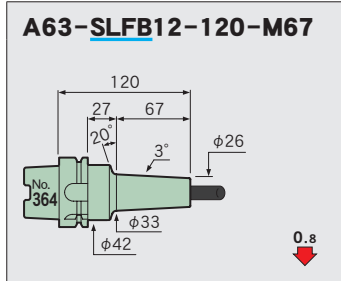
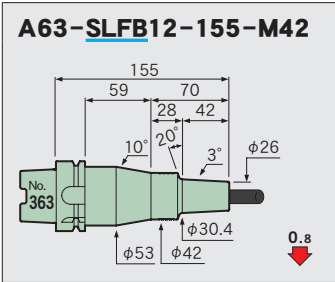
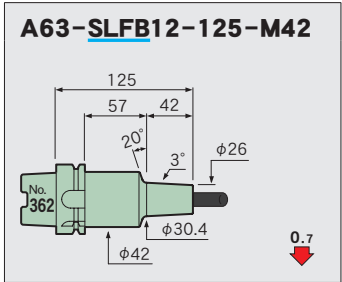
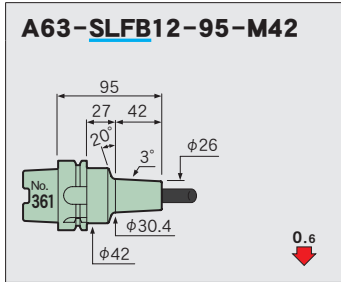
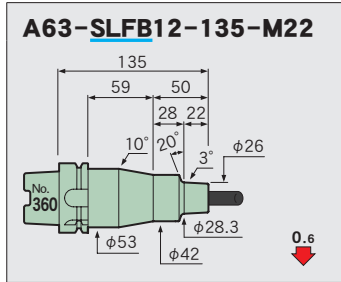
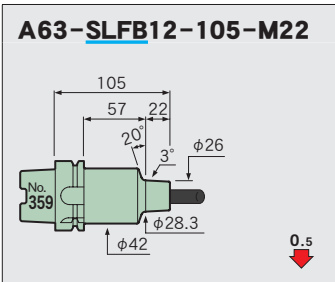
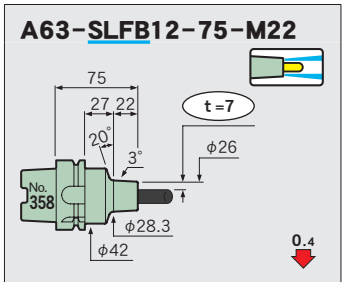
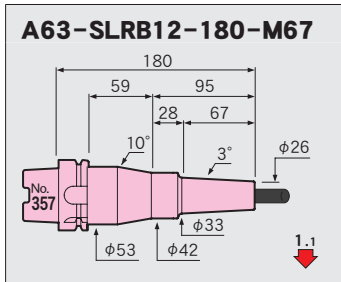
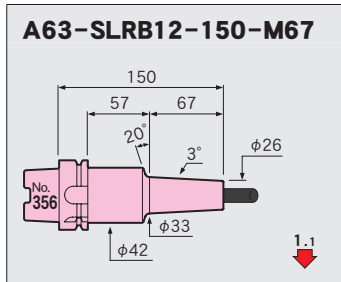
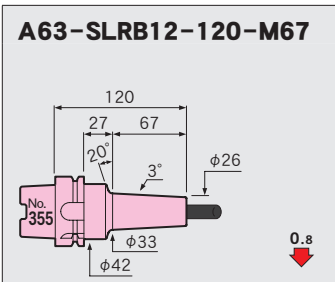
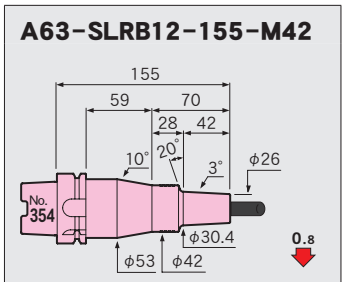
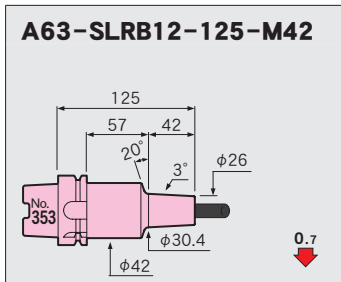
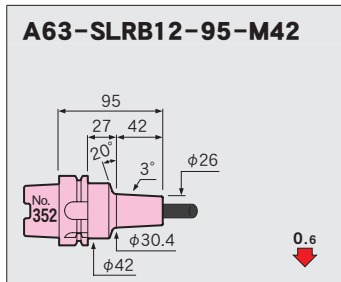
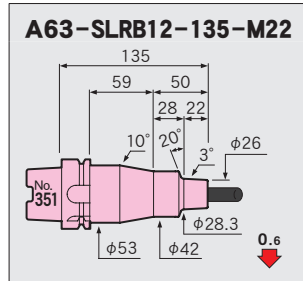
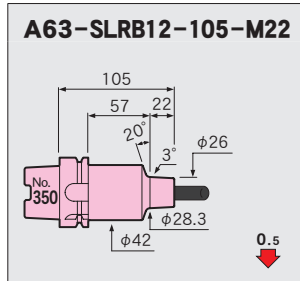
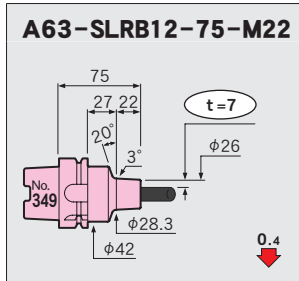
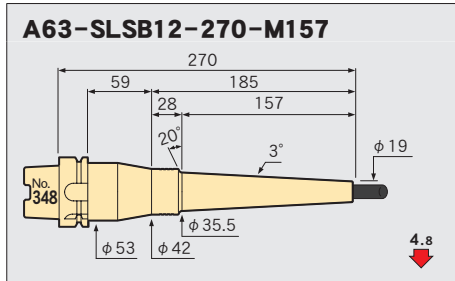
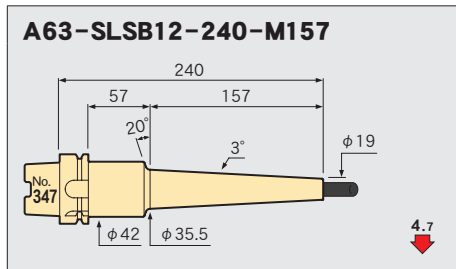
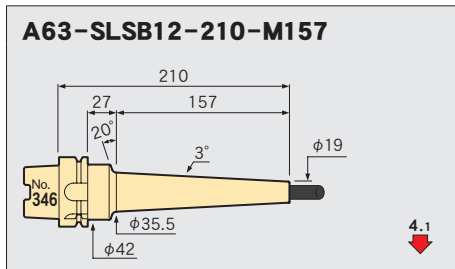
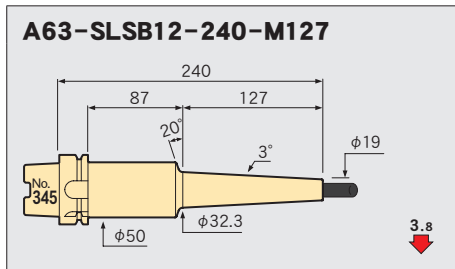

Feature
Shrink-fit Heater
MONO 3° MONO CURVE
MONO Series
2PIECE type
UNO
HYPER version
STRAIGHT arbor
OTHERS
PERIPHERALS
Technical information

Feature
Shrink-fit Heater
MONO 3° MONO CURVE
MONO Series
2PIECE type
UNO
HYPER version
STRAIGHT anbor
OTHERS
PERIPHERALS
Technical Information

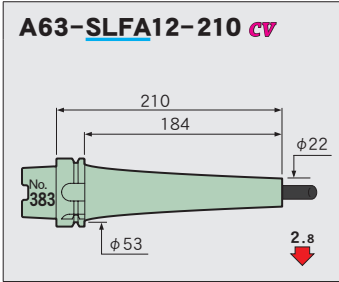
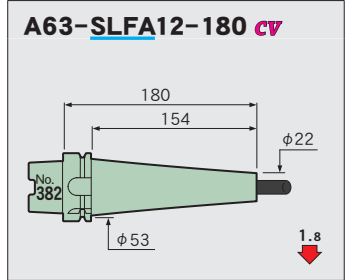
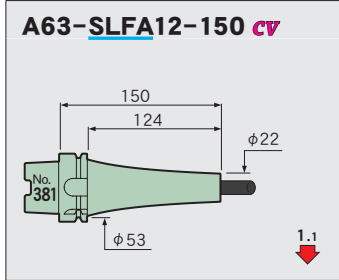
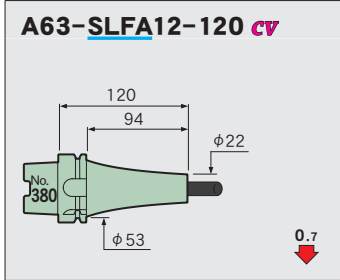
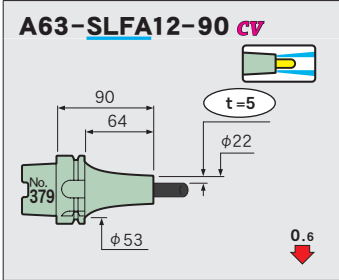
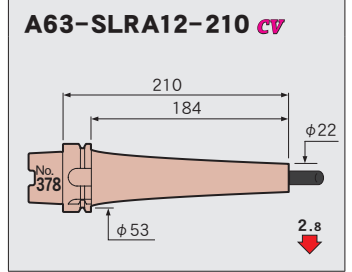
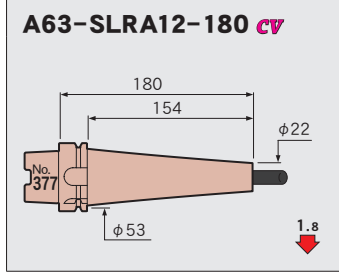
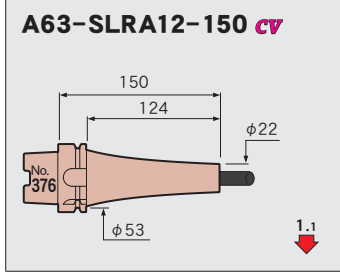
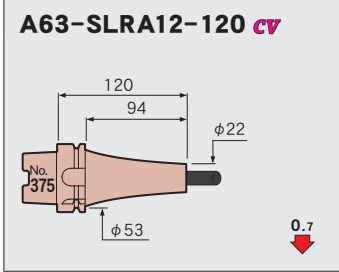
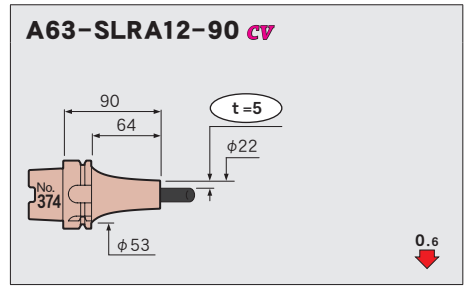
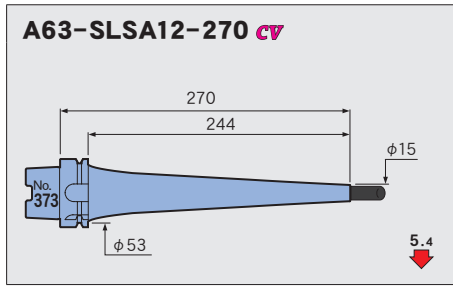
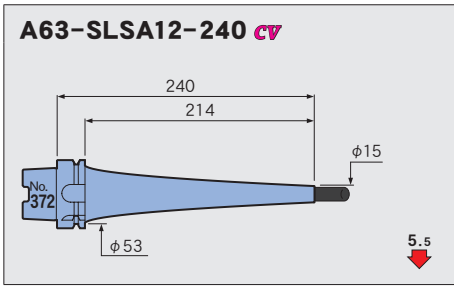

φ1/2

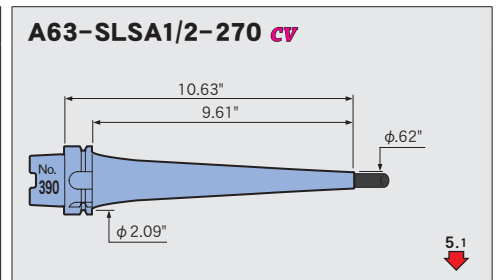
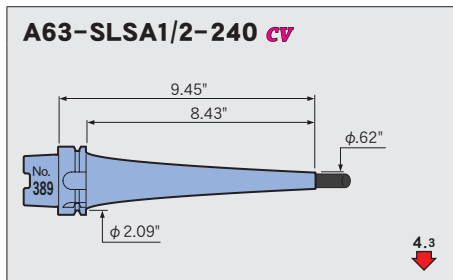
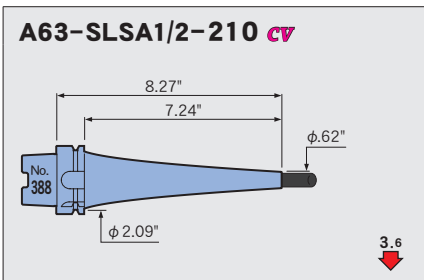
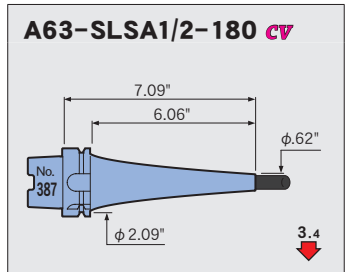
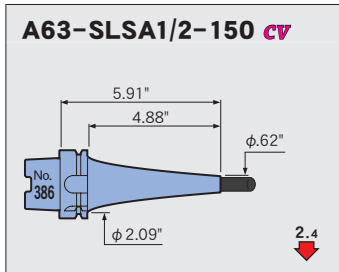
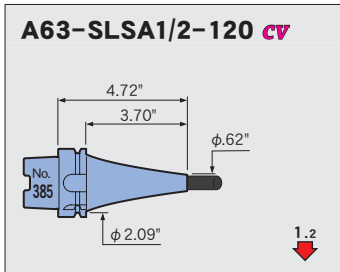
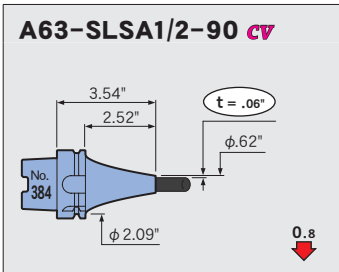

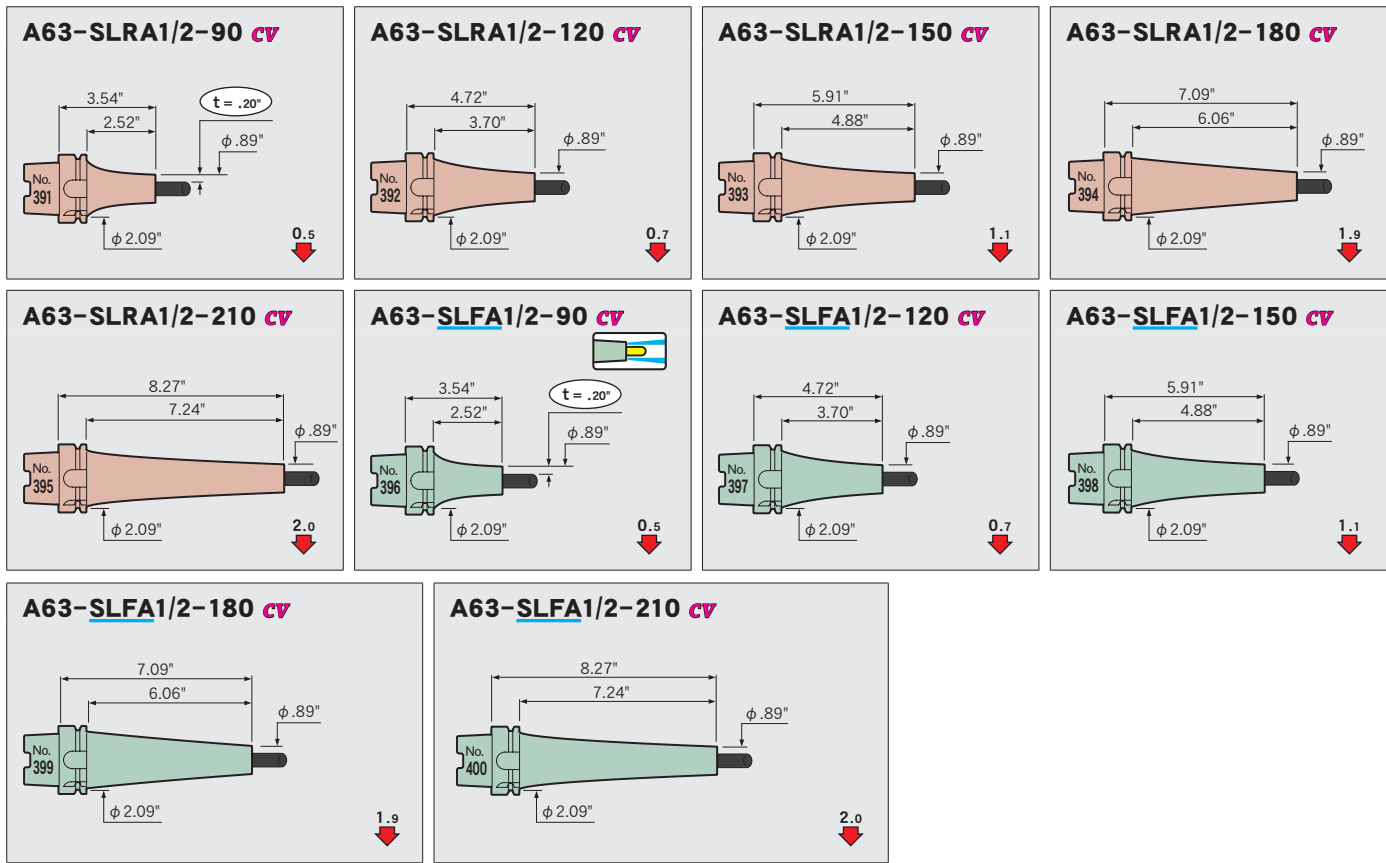

Shrink-fit Heater

MONO 3° MONO CURVE

2PIECE type

UNO

HYPER version

STRAIGHT arbor

OTHERS

PERIPHERALS

Technical Information

φ16

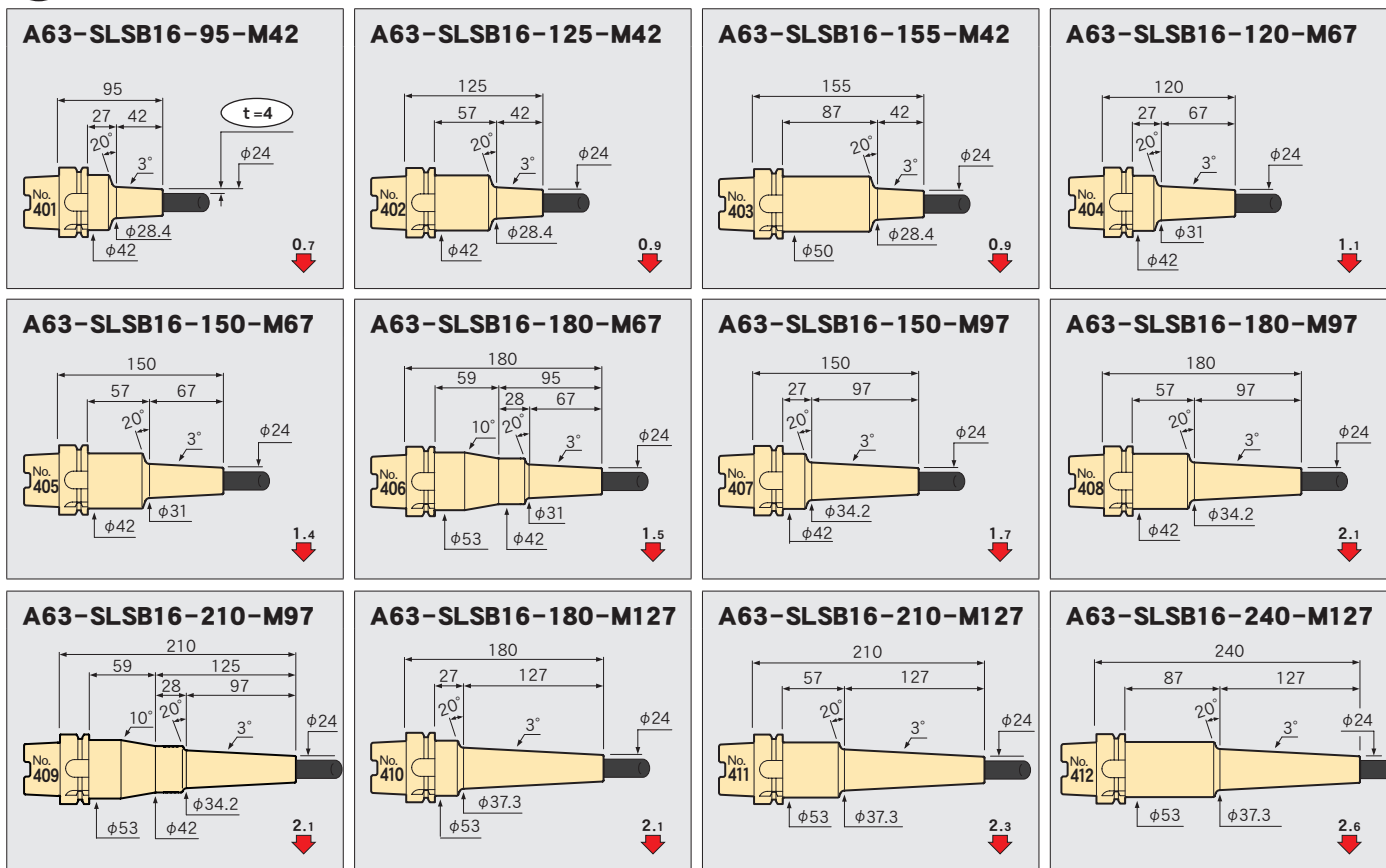

Feature

Shrink-fit Heater

MONO 3° MONO CURVE

MONO Series

2PIECE type

UNO

HYPER version

STRAIGHT anbor

OTHERS

PERIPHERALS

Technical Information

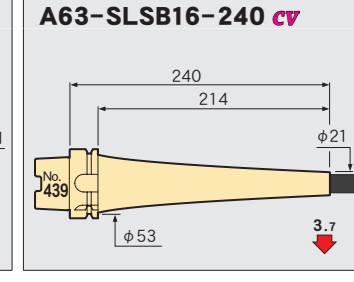
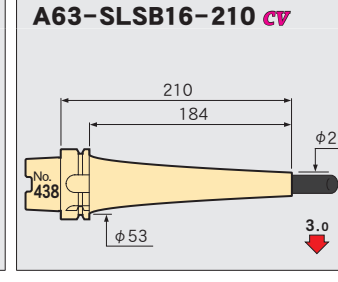
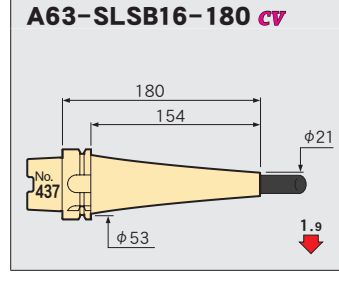
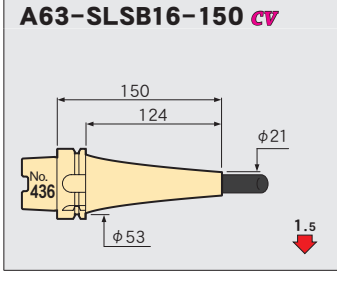
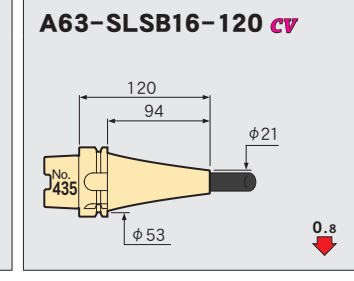
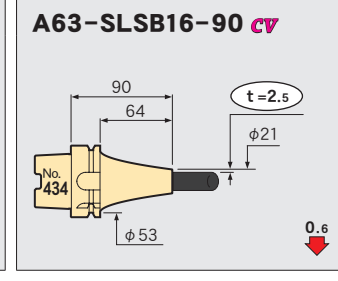
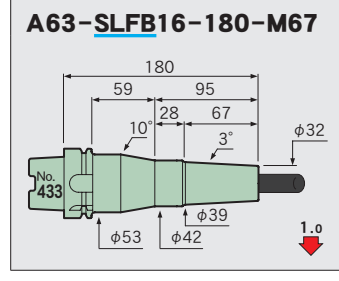
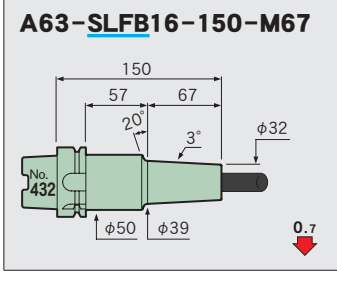
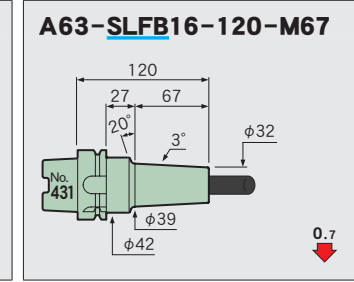
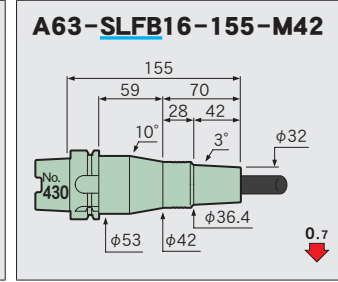
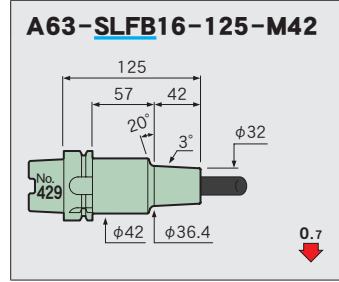
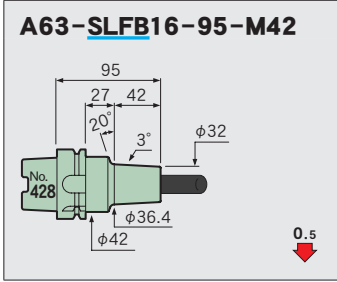
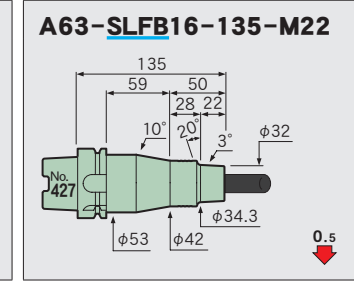
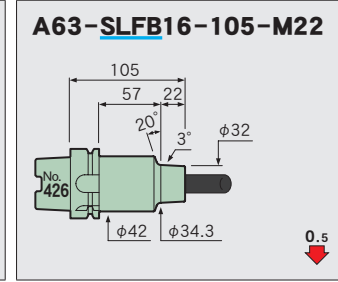
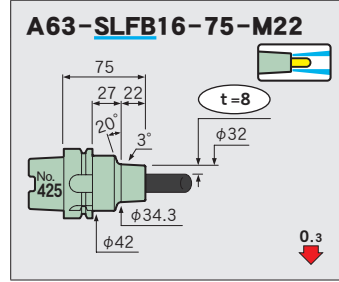
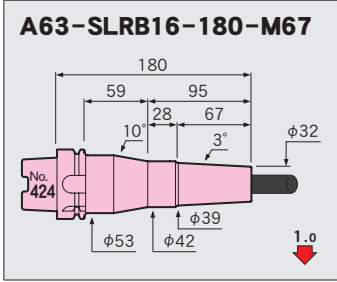
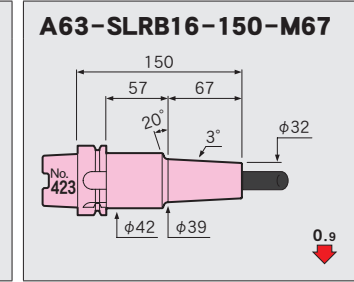
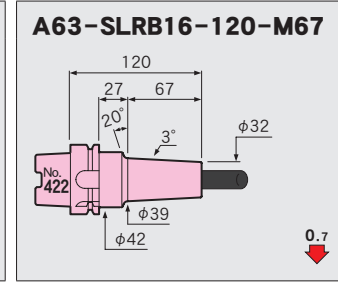
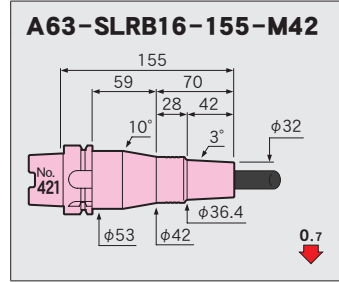
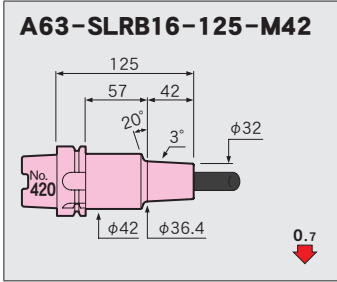
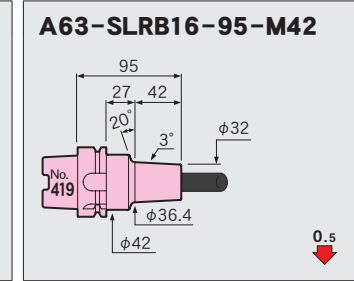
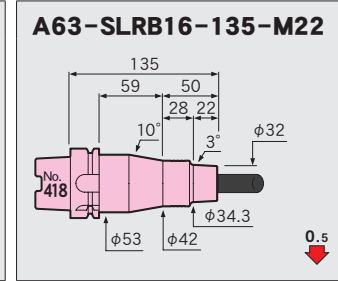
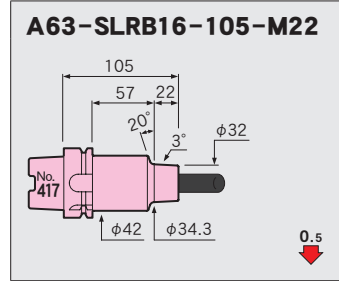
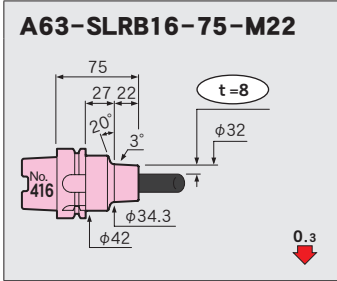
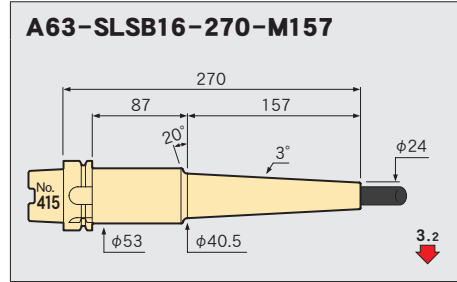
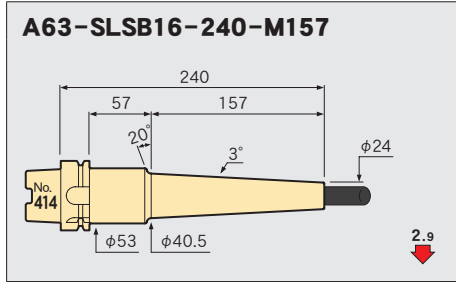
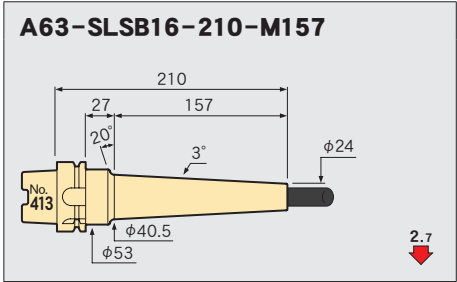

A63-SLSB16-270 CV

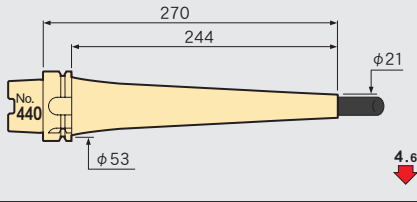

φ5/8

A63-SLSB5/8-90 CV

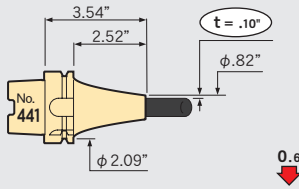

A63-SLSB5/8-120 CV

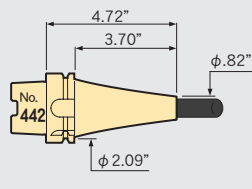

A63-SLSB5/8-150 CV

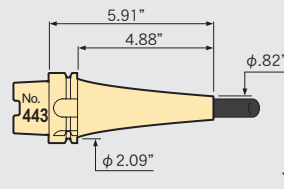

A63-SLSB5/8-180 CV

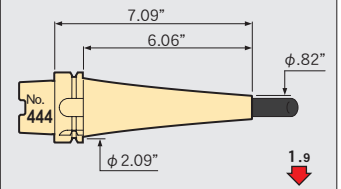

A63-SLSB5/8-210 CV

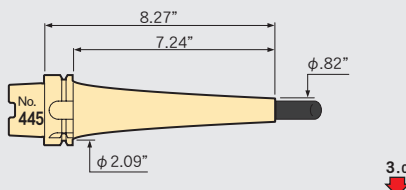

A63-SLSB5/8-240 CV

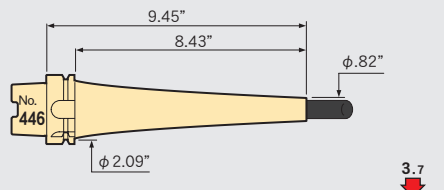

A63-SLSB5/8-270 CV

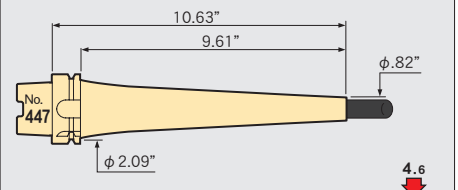

Feature
Shrink-fit Heater

MONO 3°
MONO CURVE

MONO Series

2PIECE type

UNO

HYPER
version

STRAIGHT
arbor

OTHERS

PERIPHERALS

Technical
Information

φ20

Feature
Shrink-fit Heater
MONO 3° MONO CURVE
MONO Series
2PIECE type
UNO
HYPER version
STRAIGHT arbor
OTHERS
PERIPHERALS
Technical Information

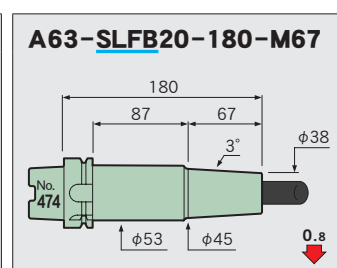
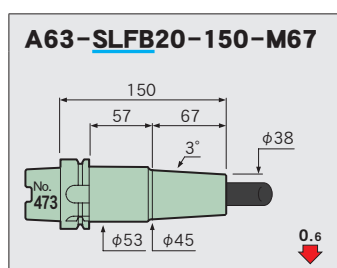
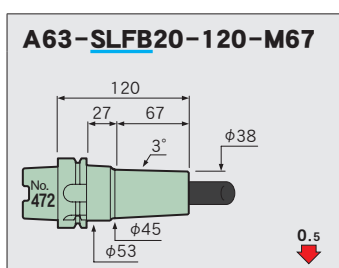
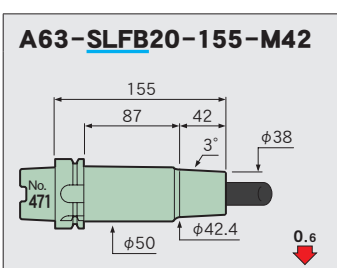
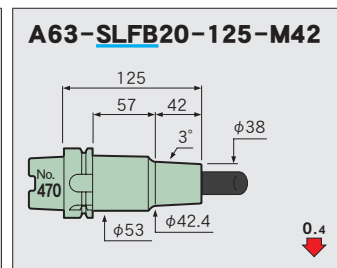
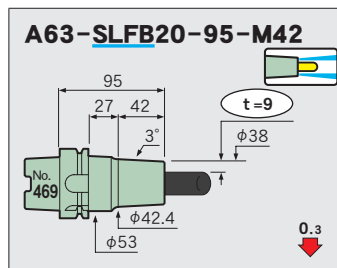
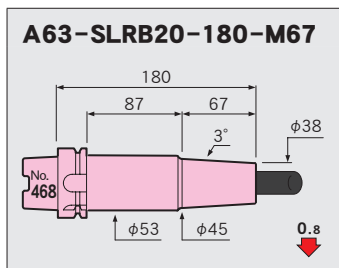
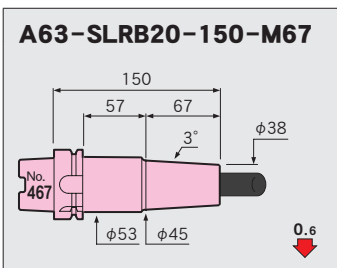
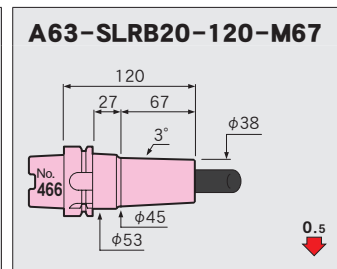
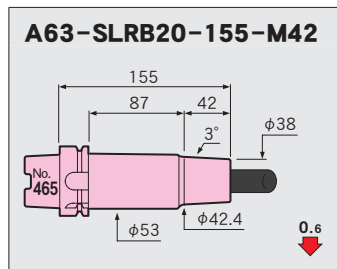
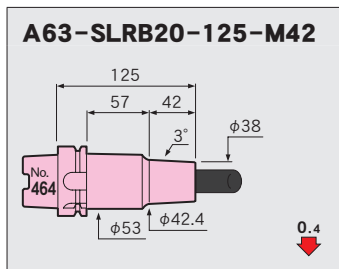
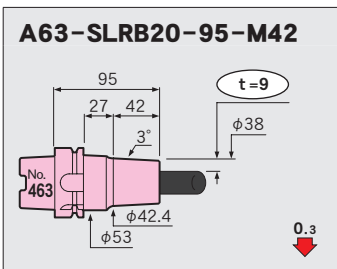
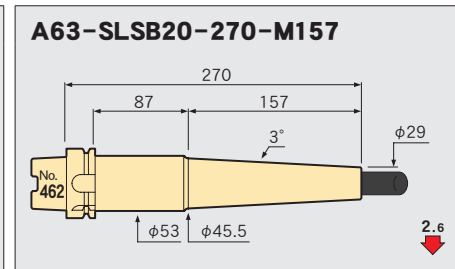
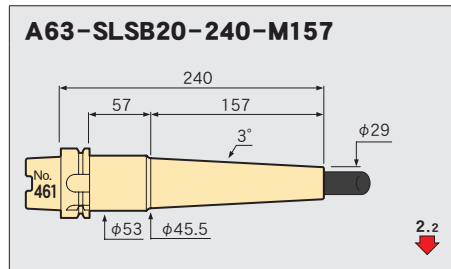
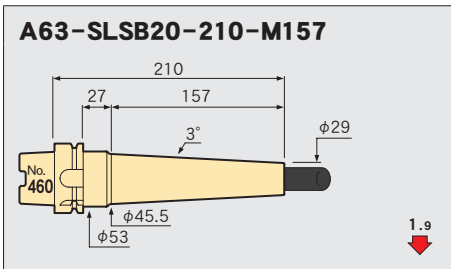
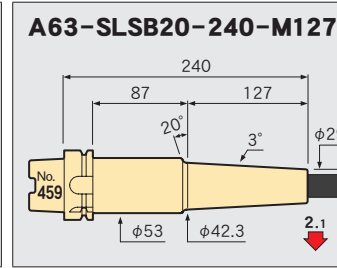
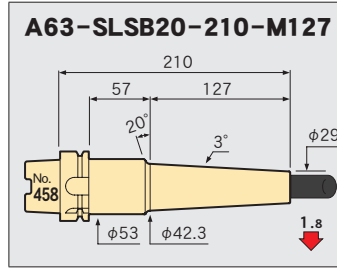
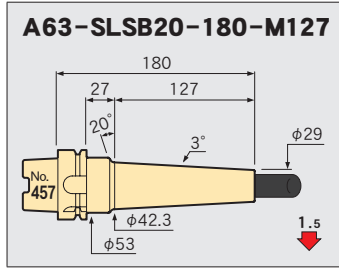
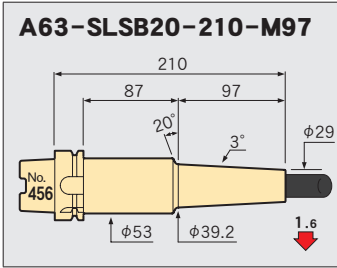
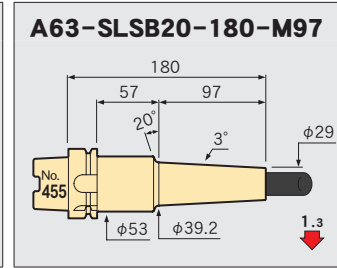
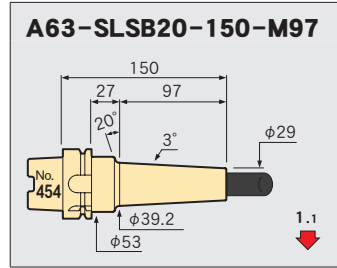
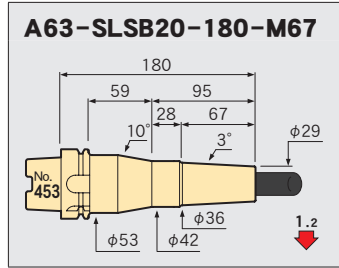
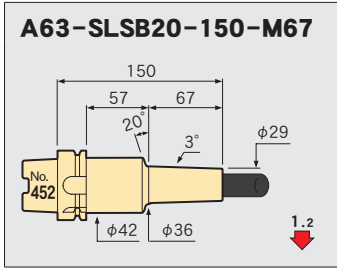
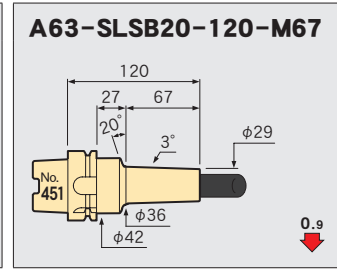
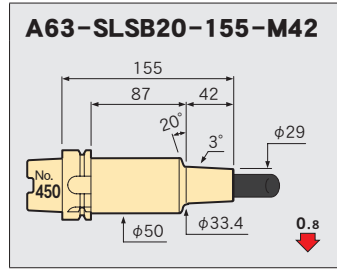
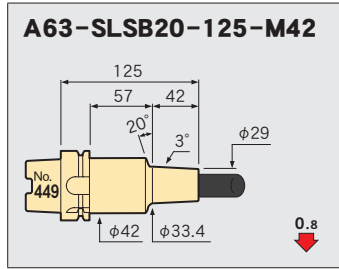
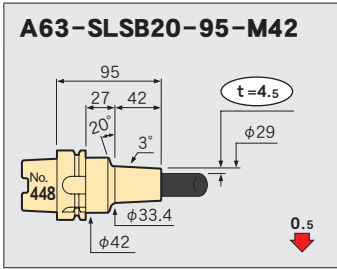

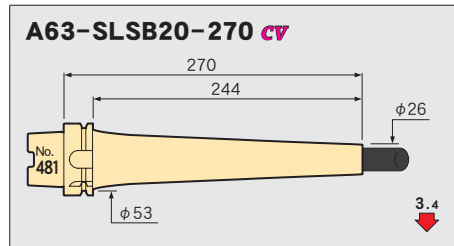
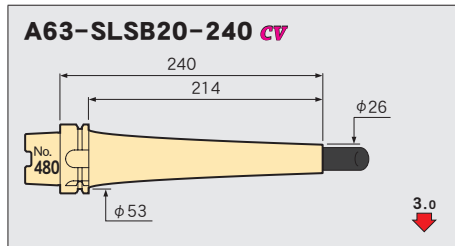
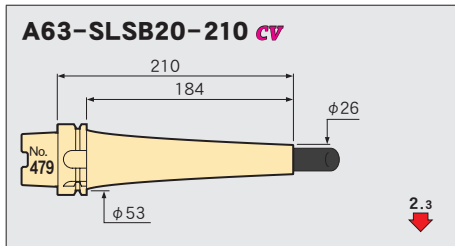
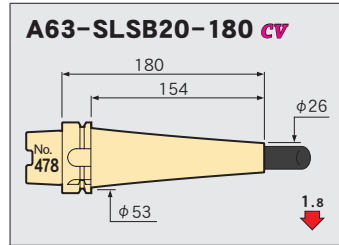
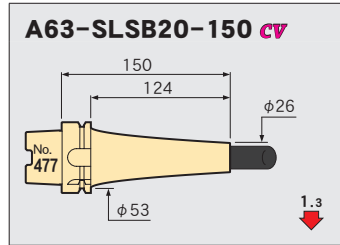
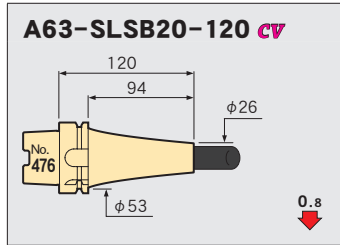
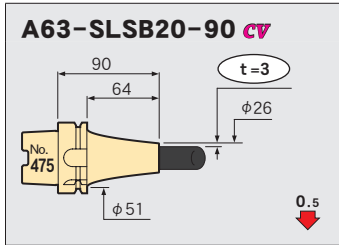

$\phi 3/4$

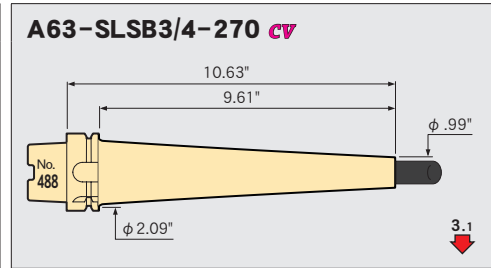
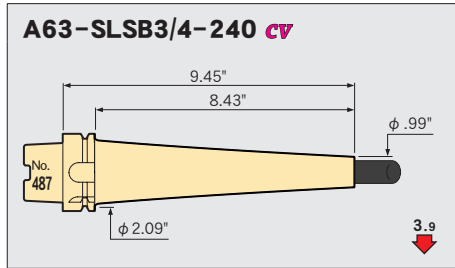
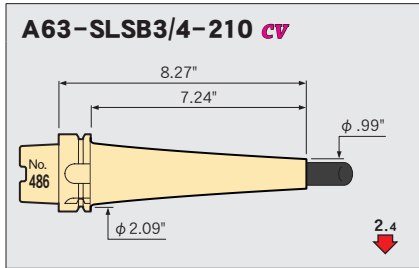
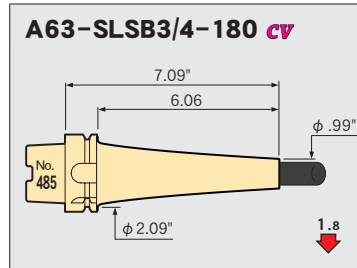
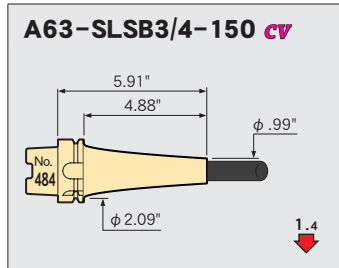
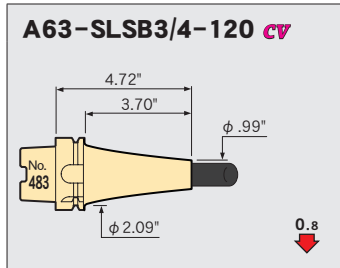
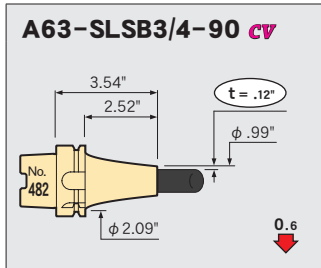

$\phi 25$

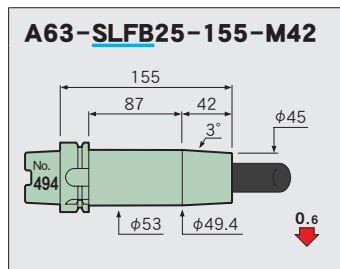
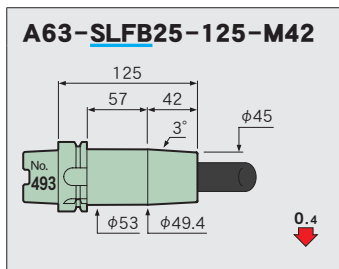
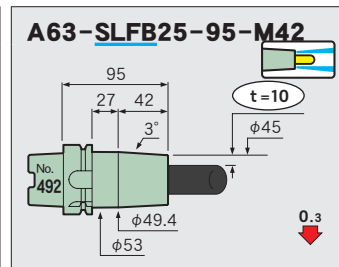
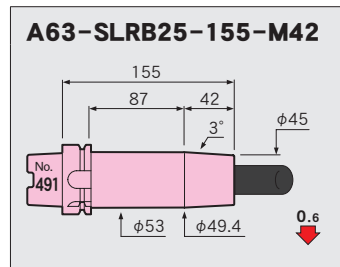
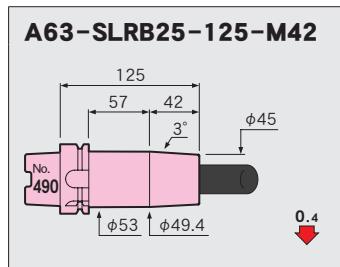
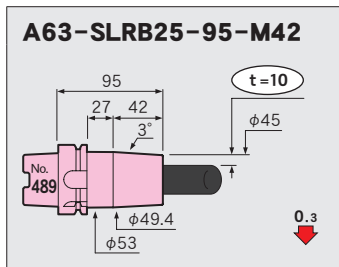

φ32

A63-SLRB32-110-M42

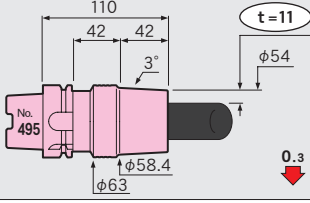

■ φ70 Nozzle (HRB-03S)

Required for shrinking the SLRB32.

CODE
HRB-NZL70

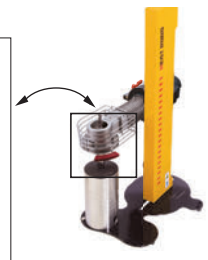
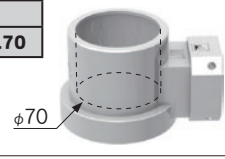

HEAT ROBO Baby 3000S

Feature

Shrink-fit Heater

MONO 3°
MONO CURVE

MONO Series

2PIECE type

UNO

HYPER
version

STRAIGHT
arbor

OTHERS

PERIPHERALS

Technical
Information

A100

MONO 3°



A100-SLSB16-285-M157

MONO CURVE CV



A100-SLRA12-225 cv

Fig. 1

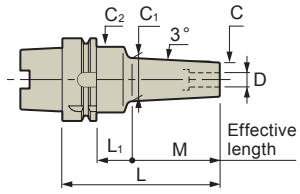

Fig. 2

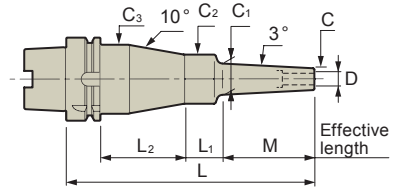
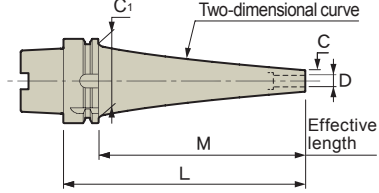

Fig. 3



■ Std. Access.
 ● Coolant duct (fixed type) → P.218

■ Note
 ● Swing type coolant ducts are available upon request. → P.218

■ Caution
 ● Setting cutters... Be sure to insert the tool beyond the safety mark.

Compatibility table for HRD-01S



[○] Available [×] Not available
 [▲] Usable by raising the heating unit. → P.233

CV : Curve

Thickness

CODE	Fig.	φD	φC	t	L	M	L1	L2	φC1	φC2	φC3	H	h	Kg	N	S	Scale model
A100-SLSA3-110-M 42	1	3	6	1.5	110	42	39	—	10.4	26	—	9	80	2.2	19.8	9.4	○
-135-M 67					135	67			13				105	2.3	20.9	15.1	4
-140-M 42					140	42	69		10.4				110		19.9	10.1	2
-165-M 67					165	67			13	25			136	2.2	21	16	5
-M 97						97	39		16.2	26			135	2.3	22.2	21	7
-170-M 42	2				170	42	33	66	10.4		40		140	2.6	20.2	10	3
-195-M 67					195	67			13				165		21.3	15.9	6
-M 97	1					97	69	—	16.2	25	—		166	2.3	22.3	22.5	8
-225-M 97	2				225		33	66		26	40		195	2.7	22.6	22.2	9
-SLRA3- 90-M 22	1	3	7.5	2.25	90	22	39	—	9.8	26	—	9	60	2.2	20.2	2.9	○
-110-M 42					110	42			11.9				80		20.6	5.5	13
-120-M 22					120	22	69		9.8	25			91		20.3	3.3	11
-135-M 67					135	67	39		14.5				106		21.4	9	16
-140-M 42					140	42	69		11.9	26			110	2.3	20.7	6.1	14
-150-M 22	2				150	22	33	66	9.8		40		120	2.6	20.6	3.2	12
-165-M 67	1				165	67	69	—	14.5	25	—		136		21.5	10.1	17
-M 97						97	39		17.7					2.2	22.4	13.1	19
-170-M 42	2				170	42	33	66	11.9	26	40		140	2.6	21	6	15
-195-M 67					195	67			14.5				165		21.8	9.9	18
-M 97	1					97	69	—	17.7		—			2.4	22.5	14.7	20
-M127						127	39		20.8	36					24.5	15.8	22
-225-M 97	2				225	97	33	66	17.7	26	40		195	2.7	22.8	14.4	21
-M127	1					127	69	—	20.8	36	—			2.6	24.6	16.4	23
-255-M127	2				255		30	69		32	46		226	3	24.9	16.6	24





CODE	Fig.	φD	φC	t	L	M	L1	L2	φC1	φC2	φC3	H	h	Kg lbs	N	S	Scale model
A100-SLFB3- 90-M 22	1	3	9.5	3.25	90	22	39	—	11.8	26	—	9	60	2.2	19.8	1.9	25
 -110-M 42					110	42			13.9				80	2.3	20.3	3.3	28
-120-M 22					120	22	69		11.8				90		19.9	2.3	26
-135-M 67					135	67	39		16.5				105		21.4	5.5	31
A100 -140-M 42					140	42	69		13.9	25			111	2.2	20.4	4.1	29
-150-M 22	2				150	22	33	66	11.8	26	40		120	2.6	20.2	2.3	27
-165-M 67	1				165	67	69	—	16.5	25	—		136	2.3	21.5	6.7	32
-170-M 42	2				170	42	33	66	13.9	26	40		140	2.6	20.7	3.9	30
-195-M 67					195	67			16.5				165		21.8	6.3	33
A100-SLSA4-110-M 42	1	4	7	1.5	110	42	39	—	11.4	25	—	12	81	2.1	21	7.2	34
-135-M 67					135	67			14				106	2.2		11.8	37
-140-M 42					140	42	69		11.4				111		21.1	8	35
-165-M 67					165	67			14				136	2.3		13.1	38
-M 97						97	39		17.2	26			135		22.4	16.9	40
-170-M 42	2				170	42	33	66	11.4		40		140	2.6	21.4	8	36
-195-M 67					195	67			14	25	39		166			12.9	39
-M 97	1					97	69	—	17.2		—			2.3	22.5	18.7	41
-225-M 97	2				225		33	66			39		196	2.6	22.8	18.3	42
-SLRA4- 90-M 22	1	4	10	3	90	22	39	—	12.3	25	—	12	61	2.1	20.3	1.8	43
-110-M 42					110	42			14.4				81	2.2	21	3.2	46
-120-M 22					120	22	69		12.3				91		20.4	2.3	44
-135-M 67					135	67	39		17				106		22	5.3	49
-140-M 42					140	42	69		14.4				111		21.1	4	47
-150-M 22	2				150	22	33	66	12.3	26	40		120	2.6	20.7	2.2	45
-165-M 67	1				165	67	69	—	17		—		135	2.4	22.1	6.3	50
-M 97						97	39		20.2	25			136	2.2	23.5	8	52
-170-M 42	2				170	42	33	66	14.4		39		141	2.6	21.4	3.8	48
-195-M 67					195	67			17				166		22.5	6.3	51
-M 97	1					97	69	—	20.2	26	—		165	2.4	23.5	9.5	53
-M127						127	39		23.3	32			166		26.7	9.6	55
-225-M 97	2				225	97	33	66	20.2	26	40		195	2.7	23.9	9.2	54
-M127	1					127	69	—	23.3	32	—		196	2.6	26.8	10.7	56
-255-M127	2				255		30	69			46		226	3	27.2	10.4	57
-SLFB4- 90-M 22	1	4	12	4	90	22	39	—	14.3	25	—	12	61	2.1	20.1	1.4	58
 -110-M 42					110	42			16.4				81	2.2	20.8	2.3	61
-120-M 22					120	22	69		14.3				91		20.2	1.9	59
-135-M 67					135	67	39		19	26			105	2.3	22	3.7	64
-140-M 42					140	42	69		16.4	25			111		20.8	3.1	62
-150-M 22	2				150	22	33	66	14.3		39		121	2.6	20.5	1.8	60
-165-M 67	1				165	67	69	—	19	26	—		135	2.4	22.1	4.7	65
-170-M 42	2				170	42	33	66	16.4	25	39		141	2.6	21.2	2.9	63
-195-M 67					195	67			19				166		22.4	4.7	66
-SLSA4-165 CV	3	4	7	1.5	165	136	—	—	85	—	—	12	133	3.4	29	2.5	67
-195 CV					195	166							163	3.7	30.6	3.3	68
-225 CV					225	196							196	4.3	33	3.8	69
-255 CV					255	226							226	4.4	34.1	5.6	70
-285 CV					285	256							256	4.6	35.5	7.6	71
-315 CV					315	286							286	4.9	37.1	9.8	72
-345 CV					345	316							316	5.2	38.8	12.4	73
A100-SLSA3/16-165 CV	3	.19	.31	.06	6.50	5.35	—	—	3.35	—	—	.59	5.35	7.0	25.2	2.4	74
-195 CV					7.68	6.54							6.54	7.6	26.9	3.3	75
-225 CV					8.86	7.72							7.72	8.7	29.1	4	76
-255 CV					10.04	8.90							8.90	9.0	30	6	77
-285 CV					11.22	10.08							10.08	9.4	32.2	8.2	78
-315 CV					12.40	11.26							11.26	10.1	33.6	10.4	79
-345 CV					13.58	12.44							12.44	10.7	35.2	13.1	80

CODE	Fig.	φD	φC	t	L	M	L ₁	L ₂	φC ₁	φC ₂	φC ₃	H	h	Kg lbs	N	S	Scale model	Feature	
A100-SLSA6-110-M 42	1	6	9	1.5	110	42	39	—	13.4	25	—	18	81	2.1	21.3	4.9	▲	81	Shrink-fit Heater
-135-M 67					135	67			16				106	2.2	22.8	8.2		84	
-140-M 42					140	42	69		13.4				111		21.4	5.8		82	
-165-M 67					165	67			16				136	2.3	22.9	9.5		85	
-M 97					97	39			19.2	32					25.3	11.1		87	
-170-M 42	2				170	42	33	66	13.4	25	39		141	2.6	21.7	5.6		83	
-195-M 67					195	67			16				166		23.2	9.3		86	
-M 97	1				97	69	—		19.2	32	—			2.4	25.4	11.9		88	
-225-M 97	2				225		30	69			46		196	2.9	25.7	11.7		89	
-SLSB6-110-M 42	1	6	10	2	110	42	39	—	14.4	25	—	18	81	2.1	22.2	3.8	○	90	MONO 3° MONO CURVE
-135-M 67					135	67			17				106	2.2	24.3	6.3		93	
-140-M 42					140	42	69		14.4				111	2.2	22.3	4.7		91	
-165-M 67					165	67			17				136	2.3	24.4	7.7		94	
-M 97					97	39			20.2	32					27.3	8.6		96	
A100 -170-M 42	2				170	42	33	66	14.4	26	40		140	2.6	22.6	4.6		92	
-195-M 67					195	67			17	25	39		166		24.7	7.4		95	
-M 97	1				97	69	—		20.2	36	—		165		27.4	9.5		97	
-M127					127	39			23.3	32			166	2.4	29.8	11.3		99	
-225-M 97	2				225	97	30	69	20.2		46		196	2.9	27.8	9.2		98	
-M127	1				127	69	—		23.3		—			2.5	29.9	12.4		100	
-M157					157	39			26.5						32.3	13.6		102	
-255-M127	2				255	127	30	69	23.3		46		226	3	30.3	12.1	▲	101	
-M157	1				157	69	—		26.5		—			2.6	32.4	15.1		103	
-285-M157	2				285		30	69			46		256	3.1	32.8	14.6		104	
-SLRB6- 90-M 22	1	6	14	4	90	22	39	—	16.3	32	—	18	61	2.2	21.1	1	○	105	2PIECE type
-110-M 42					110	42			18.4				81	2.3	22.8	1.6		108	
-120-M 22					120	22	69		16.3				91	2.4	21.3	1.2		106	
-135-M 67					135	67	39		21				106	2.3	24.9	2.7		111	
-140-M 42					140	42	69		18.4				111	2.4	22.9	2		109	
-150-M 22	2				150	22	30	69	16.3		46		121	2.8	21.6	1.2		107	
-165-M 67	1				165	67	69	—	21		—		136	2.5	25	3.2		112	
-170-M 42	2				170	42	30	69	18.4		46		141	2.9	23.3	1.9		110	
-195-M 67					195	67			21				166		25.3	3.1		113	
-SLFB6- 90-M 22	1	6	14	4	90	22	39	—	16.3	32	—	18	61	2.2	21.1	1	○	114	HYPER version
 -110-M 42					110	42			18.4				81	2.3	22.8	1.6		117	
-120-M 22					120	22	69		16.3				91	2.4	21.3	1.2		115	
-135-M 67					135	67	39		21				106	2.3	24.9	2.7		120	
-140-M 42					140	42	69		18.4				111	2.4	22.9	2		118	
-150-M 22	2				150	22	30	69	16.3		46		121	2.8	21.6	1.2		116	
-165-M 67	1				165	67	69	—	21		—		136	2.5	25	3.2		121	
-170-M 42	2				170	42	30	69	18.4		46		141	2.9	23.3	1.9		119	
-195-M 67					195	67			21				166		25.3	3.1		122	
-SLSA6-165 CV	3	6	9	1.5	165	136	—	—	85	—	—	18	136	3.3	28.8	2.1	○	123	OTHERS
-195 CV					195	166							166	4	32	2.3		124	
-225 CV					225	196							196	4.1	32.4	3.6		125	
-255 CV					255	226							226	4.8	35.9	3.9		126	
-285 CV					285	256							256	5	37.4	5.2	▲	127	
-315 CV					315	286							286	5.3	38.9	6.8		128	
-345 CV					345	316							316	5.6	40.3	8.7		129	
A100-SLSA1/4-165 CV	3	1/4	.37	.06	6.50	5.35	—	—	3.35	—	—	.71	5.35	8.0	27.1	1.5	○	130	PERIPHERALS
-195 CV					7.68	6.54							6.54	8.2	27.8	2.5		131	
-225 CV					8.86	7.72							7.72	8.4	28.5	3.9		132	
-255 CV					10.04	8.90							8.90	9.8	32.7	4.2		133	
-285 CV					11.22	10.08							10.08	10.4	34.3	5.6	▲	134	
-315 CV					12.40	11.26							11.26	11.0	36.1	7.4		135	
-345 CV					13.58	12.44							12.44	11.6	37.5	9.5		136	







Scale model

CODE	Fig.	φD	φC	t	L	M	L ₁	L ₂	φC ₁	φC ₂	φC ₃	H	h	Kg	N	S	Feature	Scale model
A100-SLSA8-110-M 42	1	8	11	1.5	110	42	39	—	15.4	36	—	24	80	2.3	23.2	3.2	○	137
-135-M 67					135	67			18	32			106		25.8	5.5		140
-140-M 42					140	42	69		15.4	36			110	2.5	23.4	3.5		138
-165-M 67					165	67			18	32			136	2.4	26	6.1		141
-M 97						97	39		21.2					2.3	29	8.1		143
-170-M 42	2				170	42	28	71	15.4	36	50		140	3.1	23.7	3.4		139
-195-M 67					195	67	30	69	18	32	46		166	2.9	26.3	5.9		142
-M 97	1					97	69	—	21.2		—			2.5	29.1	8.9		144
-225-M 97	2				225		28	71		36	50		195	3.2	29.5	8.3		145
-SLSB8-110-M 42	1	8	13	2.5	110	42	39	—	17.4	32	—	24	81	2.2	24.3	2.1	○	146
-135-M 67					135	67			20				106	2.3	27.5	3.6		149
-140-M 42					140	42	69		17.4				111	2.4	24.5	2.6		147
-165-M 67					165	67			20				136		27.7	4.2		150
-M 97						97	39		23.2						31.4	5.4		152
A100 -170-M 42	2				170	42	28	71	17.4	36	50		140	3.1	24.8	2.4		148
-195-M 67					195	67	30	69	20	32	46		166	2.9	28	4		151
-M 97	1					97	69	—	23.2		—			2.5	31.5	6.3		153
-M127						127	39		26.3					2.4	35.3	7.3		155
-225-M 97	2				225	97	30	69	23.2		46		196	3	31.9	6		154
-M127	1					127	69	—	26.3		—			2.6	35.4	8.5		156
-M157						157	39		29.5	42				2.7	39.1	8.1		158
-255-M127	2				255	127	30	69	26.3	32	46		226	3.1	35.7	8.2	▲	157
-M157	1					157	69	—	29.5	42	—			2.9	39.3	8.7		159
-285-M157	2				285		28	71			56		256	3.6	39.6	8.6		160
-SLRB8- 90-M 22	1	8	18	5	90	22	39	—	20.3	32	—	24	61	2.2	21.8	0.7	×	161
-110-M 42					110	42			22.4				81	2.3	24.4	1.1	○	164
-120-M 22					120	22	69		20.3				91	2.4	22	1	×	162
-135-M 67					135	67	39		25				106		27.6	1.8	○	167
-140-M 42					140	42	69		22.4				111		24.5	1.6		165
-150-M 22	2				150	22	30	69	20.3		46		121	2.9	22.3	1	×	163
-165-M 67	1				165	67	69	—	25		—		136	2.5	27.8	2.4	○	168
-170-M 42	2				170	42	28	71	22.4	36	50		140	3.1	24.9	1.3		166
-195-M 67					195	67	30	69	25	32	46		166	3	28.1	2.2		169
-SLFB8- 90-M 22	1	8	18	5	90	22	39	—	20.3	32	—	24	61	2.2	21.8	0.7	×	170
 -110-M 42					110	42			22.4				81	2.3	24.4	1.1	○	173
-120-M 22					120	22	69		20.3				91	2.4	22	1	×	171
-135-M 67					135	67	39		25	36			105		27.6	1.7	○	176
-140-M 42					140	42	69		22.4	32			111		24.5	1.6		174
-150-M 22	2				150	22	30	69	20.3		46		121	2.9	22.3	1	×	172
-165-M 67	1				165	67	69	—	25		—		136	2.5	27.8	2.4	○	177
-170-M 42	2				170	42	30	69	22.4		46		141	2.9	24.9	1.5		175
-195-M 67					195	67			25				166	3	28.1	2.2		178
-SLSA8-165 CV	3	8	11	1.5	165	136	—	—	85	—	—	24	136	3.7	30.7	1.4	○	179
-195 CV					195	166							166		31	2.3		180
-225 CV					225	196							196	4.6	35.3			181
-255 CV					255	226							226		35.9	3.6	▲	182
-285 CV					285	256							256	4.9	37.4	4.8		183
-315 CV					315	286							286	5.7	41.9	5		184
-345 CV					345	316							311	6.1	45.1	6		185
-SLRA8-195 CV	3	8	16	4	195	166	—	—	85	—	—	24	166	3.7	28.5	1.4	○	186
-225 CV					225	196							196	4.4	32.3	1.6		187
-255 CV					255	226							226	4.6	33.6	2.2	▲	188
-285 CV					285	256							256	4.8	34.8	3		189
-SLFA8-195 CV	3	8	16	4	195	166	—	—	85	—	—	24	166	3.7	28.5	1.4	○	190
 -225 CV					225	196							196	4.4	32.3	1.6		191
-255 CV					255	226							226	4.6	33.6	2.2	▲	192
-285 CV					285	256							256	4.8	34.8	3		193

CODE	Fig.	ϕD	ϕC	t	L	M	L ₁	L ₂	ϕC_1	ϕC_2	ϕC_3	H	h	Kg lbs	N	S	Scale model	Feature	
A100-SLSA5/16-165 CV	3	5/16	.43	.06	6.50	5.35	—	—	3.35	—	—	.94	5.35	7.8	26.6	1.5	○	194	Shrink-fit Heater
-195 CV					7.68	6.54							6.54	7.9	27.2	2.4	○	195	
-225 CV					8.86	7.72							7.72	9.6	31.2	2.5	○	196	
-255 CV					10.04	8.90							8.90		32.4	3.9	▲	197	
-285 CV					11.22	10.08							10.08	10.2	34.2	5.3	○	198	
-315 CV					12.40	11.26							11.26	11.9	38.4	5.4	○	199	
-345 CV					13.58	12.44							12.44	12.3	43.5	6.6	○	200	
-SLRA5/16-195 CV	3	5/16	.63	.16	7.68	6.54	—	—	3.35	—	—	.94	6.54	8.3	28	1.4	○	201	
-225 CV					8.86	7.72							7.72	9.7	32.2	1.6	○	202	
-255 CV					10.04	8.90							8.90	10.1	33.5	2.3	▲	203	
-285 CV					11.22	10.08							10.08	10.6	35.1	3.1	○	204	
-SLFA5/16-195 CV	3	5/16	.63	.16	7.68	6.54	—	—	3.35	—	—	.94	6.54	8.3	28	1.4	○	205	MONO Series
-225 CV					8.86	7.72							7.72	9.7	32.2	1.6	○	206	
-255 CV					10.04	8.90							8.90	10.1	33.5	2.3	▲	207	
-285 CV					11.22	10.08							10.08	10.6	35.1	3.1	○	208	
A100-SLSA10-110-M 42	1	10	13	1.5	110	42	39	—	17.4	25	—	30	81	2.2	24.6	2.7	○	209	2PIECE type
-135-M 67					135	67			20	32			106	2.3	28.5	4.1	○	212	
-140-M 42					140	42	69		17.4	25			111	2.2	24.8	3.8	○	210	
-165-M 67					165	67			20	36			135	2.5	28.6	4.4	○	213	
-M 97						97	39		23.2	32			136	2.3	33.2	6.2	○	215	
-170-M 42	2				170	42	28	71	17.4	36	50		140	3.1	25.1	2.5	○	211	
-195-M 67					195	67	30	69	20	32	46		166	2.9	29	4.6	○	214	
-M 97	1					97	69	—	23.2	—				2.5	33.3	7.1	○	216	
-225-M 97	2				225		30	69			46		196	3	33.7	6.9	▲	217	
-SLSB10-110-M 42	1	10	16	3	110	42	39	—	20.4	32	—	30	81	2.3	25.8	1.2	○	218	
-135-M 67					135	67			23				106		30.4	2.5	○	221	
-140-M 42					140	42	69		20.4				111	2.4	25.9	2	○	219	
-165-M 67					165	67			23				136	2.5	30.5	3.2	○	222	
-M 97						97	39		26.2					2.4	35.9	3.8	○	224	
A100 -170-M 42	2				170	42	30	69	20.4		46		141	2.9	26.3	1.9	○	220	
-195-M 67					195	67			23				166		30.9	3	○	223	
-M 97	1					97	69	—	26.2	—				2.6	36.1	4.8	○	225	
-M127						127	39		29.3	42					42.1	4.6	○	227	
-225-M 97	2				225	97	30	69	26.2	32	46		196	3	36.4	4.5	▲	226	
-M127	1					127	69	—	29.3	42	—			2.9	42.5	5	○	228	
-M157						157	39		32.5					2.8	47.7	5.7	○	230	
-255-M127	2				255	127	28	71	29.3		56		226	3.5	42.8	4.9	○	229	
-M157	1					157	69	—	32.5	—			226	3	48.1	6.2	○	231	
-285-M157	2				285		28	71			56		256	3.7	48.4	6.1	○	232	
-SLRB10- 90-M 22	1	10	22	6	90	22	39	—	24.3	32	—	30	61	2.3	22.2	0.6	×	233	STRAIGHT arbor
-110-M 42					110	42			26.4				81		25.9	0.9	○	236	
-120-M 22					120	22	69		24.3				91	2.4	22.3		×	234	
-135-M 67					135	67	39		29	42			106	2.5	30.5	1.1	○	239	
-140-M 42					140	42	69		26.4	32			111		26	1.4	○	237	
-150-M 22	2				150	22	28	71	24.3	36	50		120	3.1	22.7	0.7	×	235	
-165-M 67	1				165	67	69	—	29	42	—		136	2.8	30.6	1.3	○	240	
-170-M 42	2				170	42	28	71	26.4	36	50		140	3.2	26.3	1	○	238	
-195-M 67					195	67			29	42	56		166	3.5	31	1.3	○	241	
A100 -SLFB10- 90-M 22	1	10	22	6	90	22	39	—	24.3	32	—	30	61	2.3	22.2	0.6	×	242	PERIPHERALS
-110-M 42					110	42			26.4				81		25.9	0.9	○	245	
-120-M 22					120	22	69		24.3	32			91	2.4	22.3		×	243	
-135-M 67					135	67	39		29	36			105	2.5	30.5	1.2	○	248	
-140-M 42					140	42	69		26.4				110	2.6	26	1.1	○	246	
-150-M 22	2				150	22	30	69	24.3	32	46		121	2.9	22.7	0.9	×	244	
-165-M 67	1				165	67	69	—	29	36	—		135	2.7	30.6	1.6	○	249	
-170-M 42	2				170	42	30	69	26.4	32	46		141	2.9	26.3	1.3	○	247	
-195-M 67					195	67	28	71	29	42	56		166	3.5	31		○	250	



Feature Shrink-fit Heater MONO 3° MONO CURVE MONO Series 2PIECE type UNO HYPER version STRAIGHT anbor OTHERS PERIPHERALS Technical Information

CODE	Fig.	φD	φC	t	L	M	L ₁	L ₂	φC ₁	φC ₂	φC ₃	H	h	Kg lbs	N	S	Scale model
A100-SLSA10-165 CV	3	10	13	1.5	165	136	—	—	85	—	—	30	136	3.5	29.4	1.4	251
-195 CV					195	166							166	4.3	33.6	1.5	252
-225 CV					225	196							196	4.2	33.4	2.4	253
-255 CV					255	226							226	4.5	34.3	3.5	254
-285 CV					285	256							251	5.1	38.3	3.6	255
-315 CV					315	286							286		39.9	4.8	256
-345 CV					345	316							311	5.9	42.7	5.5	257
-SLRA10-165 CV	3	10	19	4.5	165	136	—	—	85	—	—	30	136	3.5	27.6	1	258
-195 CV					195	166							166	4	30.1	1.1	259
-225 CV					225	196							196	4.1	31.1	1.6	260
-255 CV					255	226							226	4.9	35.3	1.7	261
-285 CV					285	256							256	5	36.2	2.4	262
-SLFA10-165 CV	3	10	19	4.5	165	136	—	—	85	—	—	30	136	3.5	27.6	1	263
-195 CV					195	166							166	4	30.1	1.1	264
-225 CV					225	196							196	4.1	31.1	1.6	265
-255 CV					255	226							226	4.9	35.3	1.7	266
-285 CV					285	256							256	5	36.2	2.4	267
A100-SLSA3/8-165 CV	3	3/8	.49	.06	6.50	5.35	—	—	3.35	—	—	1.18	5.35	7.5	26	1.4	268
-195 CV					7.68	6.54							6.54	9.2	30	1.5	269
-225 CV					8.86	7.72							7.72		30.4	2.5	270
-255 CV					10.04	8.90							8.90	9.4	32.2	3.8	271
-285 CV					11.22	10.08							10.08	10.5	38.4	4	272
-315 CV					12.40	11.26							11.26	11.6	38.2	5.2	273
-345 CV					13.58	12.44							12.44	12.2	44	6.2	274
-SLRA3/8-165 CV	3	3/8	.73	.18	6.50	5.35	—	—	3.35	—	—	1.18	5.35	8.5	28.9	0.8	275
-195 CV					7.68	6.54							6.54	8.8	30.1	1.1	276
-225 CV					8.86	7.72							7.72	9.2	31.3	1.6	277
-255 CV					10.04	8.90							8.90	10.9	35.5	1.7	278
-285 CV					11.22	10.08							10.08	11.3	36.6	2.4	279
-SLFA3/8-165 CV	3	3/8	.73	.18	6.50	5.35	—	—	3.35	—	—	1.18	5.35	8.5	28.9	0.8	280
-195 CV					7.68	6.54							6.54	8.8	30.1	1.1	281
-225 CV					8.86	7.72							7.72	9.2	31.3	1.6	282
-255 CV					10.04	8.90							8.90	10.9	35.5	1.7	283
-285 CV					11.22	10.08							10.08	11.3	36.6	2.4	284
A100-SLSA12-110-M 42	1	12	15	1.5	110	42	39	—	19.4	32	—	30	79	2.2	27	1.9	285
-135-M 67					135	67			22				104	2.3	32.5	3.4	288
-140-M 42					140	42	69		19.4				109	2.4	27.2	2.4	286
-165-M 67					165	67			22				134		32.6	4.1	289
-M 97					97	39			25.2					2.3	39.4	5.1	291
-170-M 42	2				170	42	28	71	19.4	36	50		135	3.1	27.5	2.1	287
-195-M 67					195	67	30	69	22	32	46		164	2.9	32.9	3.9	290
-M 97	1					97	69	—	25.2	36	—		160	2.7	39.6	5.5	292
-225-M 97	2				225		30	69		32	46		194	3	39.9	5.8	293
-SLSB12-110-M 42	1	12	19	3.5	110	42	39	—	23.4	32	—	30	79	2.3	28.4	1.2	294
-135-M 67					135	67			26				104		34.7	2	297
-140-M 42					140	42	69		23.4				109	2.4	28.5	1.7	295
-165-M 67					165	67			26				134	2.5	34.8	2.7	298
-M 97					97	39			29.2	42			133	2.6	42.9	2.5	300
-170-M 42	2				170	42	28	71	23.4	36	50		135	3.1	28.9	1.4	296
-195-M 67					195	67	30	69	26	32	46		164	3	35.2	2.5	299
-M 97	1					97	69	—	29.2	50	—		160	3.1	43.2	2.6	301
-M127					127	39			32.3	42			163	2.7	50.4	3.3	303
-225-M 97					225	97	99		29.2	50			190	3.4	43.6	2.8	302
-M127					127	69			32.3	42			192	3	50.8	3.8	304
-M157					157	39			35.5				193	2.9	58	4.2	306
-255-M127	2				255	127	28	71	32.3		56		222	3.6	51.1	3.7	305
-M157	1				157	69	—	—	35.5		—			3.1	58.3	4.8	307
-285-M157	2				285		28	71			56		252	3.8	58.7	4.7	308

CODE	Fig.	φD	φC	t	L	M	L ₁	L ₂	φC ₁	φC ₂	φC ₃	H	h	Kg lbs	N	S		Scale model
A100-SLRB12- 90-M 22	1	12	26	7	90	22	39	—	28.3	42	—	30	58	2.4	26.5	0.4	×	309
-110-M 42					110	42			30.4				78	2.5	29.2	0.6		312
-120-M 22					120	22	69		28.3				87	2.6	26.8	0.5		310
-135-M 67					135	67	39		33				103		35.5	0.9		315
-140-M 42					140	42	69		30.4				107	2.7	29.6	0.8		313
-150-M 22					150	22	99		28.3	50			117	3.3	27.2	0.5		311
-165-M 67					165	67	69		33	42			132	2.9	35.8	1.1		316
-170-M 42					170	42	99		30.4	50			135	3.3	29.9	0.8		314
-195-M 67	2				195	67	28	71	33	42	56		162	3.5	36.2	1.1		317
-SLFB12- 90-M 22	1	12	26	7	90	22	39	—	28.3	42	—	30	58	2.4	26.5	0.4	×	318
 -110-M 42					110	42			30.4				78	2.5	29.2	0.6		321
-120-M 22					120	22	69		28.3				87	2.6	26.8	0.5		319
-135-M 67					135	67	39		33				103		35.5	0.9		324
-140-M 42					140	42	69		30.4	50			105	3	29.6	0.6		322
A100 -150-M 22	2				150	22	28	71	28.3	42	56		117	3.3	27.2	0.5		320
-165-M 67	1				165	67	69	—	33		—		132	2.9	35.8	1.1		325
-170-M 42					170	42	99		30.4	50			135	3.3	29.9	0.8		323
-195-M 67	2				195	67	28	71	33	42	56		162	3.5	36.2	1.1		326
-SLSA12-165 CV	3	12	15	1.5	165	136	—	—	85	—	—	30	133	4.2	34.1	1.2	○	327
-195 CV					195	166							163	4.1	33.6			328
-225 CV					225	196							175	4.8	38.3	1.8		329
-255 CV					255	226							190		37.8	2.6	▲	330
-285 CV					285	256							251	5.5	42.5	3.5		331
-315 CV					315	286							281	5.9	44.6	4.3		332
-345 CV					345	316							311	6.2	46.7	5.3		333
-SLRA12-165 CV	3	12	22	5	165	136	—	—	85	—	—	30	133	3.6	27.9	0.8	×	334
-195 CV					195	166							163	4.4	32.2			335
-225 CV					225	196							159		32.7	1.3	○	336
-255 CV					255	226							221	4.6	36.1	1.6	▲	337
-285 CV					285	256							251	5	38.5	2.1		338
-SLFA12-165 CV	3	12	22	5	165	136	—	—	85	—	—	30	133	3.6	27.9	0.8	×	339
 -195 CV					195	166							163	4.4	32.2			340
-225 CV					225	196							159		32.7	1.3	○	341
-255 CV					255	226							221	4.6	36.1	1.6	▲	342
-285 CV					285	256							251	5	38.5	2.1		343
A100-SLSA1/2-165 CV	3	1/2	.62	.06	6.50	5.35	—	—	3.35	—	—	1.18	5.28	7.5	26.8	1.2	○	344
-195 CV					7.68	6.54							6.46	9.2	31.2	1.3		345
-225 CV					8.86	7.72							6.89	9.6	32.7	1.9		346
-255 CV					10.04	8.90							7.48	10.1	34.2	2.8	▲	347
-285 CV					11.22	10.08							9.92	10.2	39.6	3.8		348
-315 CV					12.40	11.26							11.10	11.0	42.4	4.7		349
-345 CV					13.58	12.44							12.28	11.8	45.9	5.9		350
-SLRA1/2-165 CV	3	1/2	.89	.20	6.50	5.35	—	—	3.35	—	—	1.18	5.20	8.8	31.7	0.6	×	351
-195 CV					7.68	6.54							5.71	9.4	31.5	0.9		352
-225 CV					8.86	7.72								11.2	35.8	1.0	○	353
-255 CV					10.04	8.90							8.74	12.1	42.1	1.1	▲	354
-285 CV					11.22	10.08							9.92	10.8	41.0	2.2		355
-SLFA1/2-165 CV	3	1/2	.89	.20	6.50	5.35	—	—	3.35	—	—	1.18	5.20	8.8	31.7	0.6	×	356
 -195 CV					7.68	6.54							5.71	9.4	31.5	0.9		357
-225 CV					8.86	7.72								11.2	35.8	1.0	○	358
-255 CV					10.04	8.90							8.74	12.1	42.1	1.1	▲	359
-285 CV					11.22	10.08							9.92	10.8	41.0	2.2		360

Feature
Shrink-fit Heater
MONO 3° MONO CURVE
MONO Series
2PIECE type
UNO
HYPER version
STRAIGHT arbor
OTHERS
PERIPHERALS
Technical Information

CODE	Fig.	φD	φC	t	L	M	L1	L2	φC1	φC2	φC3	H	h	Kg lbs	N	S	Scale model
A100-SLSB16-110-M 42	1	16	24	4	110	42	39	—	28.4	42	—	32	78	2.4	34.7	0.7	361
-135-M 67					135	67			31				103	2.5	45	1.2	364
-140-M 42					140	42	69		28.4				107	2.7	35	0.9	362
-165-M 67					165	67			31				132	2.8	45.4	1.4	365
A100 -M 97						97	39		34.2				133	2.7	57.4	1.7	367
-170-M 42					170	42	99		28.4	50			135	3.2	35.4	0.9	363
-195-M 67					195	67			31				160	3.3	45.7	1.4	366
-M 97						97	69		34.2	42			162	2.9	57.8	2.1	368
-M127						127	39		37.3	50			160	3	69.8	2.2	370
-225-M 97	2				225	97	28	71	34.2	42	56		192	3.6	58.1	2.1	369
-M127	1					127	69	—	37.3	53	—		190	3.4	70.2	2.3	371
-M157						157	39		40.5				193	3.3	82.3	2.6	373
-255-M127	2				255	127	28	71	37.3		67		220	4.3	70.6	2.3	372
-M157	1					157	69	—	40.5		—			3.7	82.6	2.9	374
-285-M157	2				285		28	71			67		250	4.6	83		375
-SLRB16- 90-M 22	1	16	32	8	90	22	39	—	34.3	42	—	32	58	2.4	26.5	0.4	376
-110-M 42					110	42			36.4				78	2.5	34.8	0.5	379
-120-M 22					120	22	69		34.3				87	2.7	26.9		377
-135-M 67					135	67	39		39				103		45.2	0.7	382
-140-M 42					140	42	69		36.4				107	2.8	35.2		380
-150-M 22	2				150	22	28	71	34.3		56		117	3.4	27.2	0.5	378
-165-M 67	1				165	67	69	—	39		—		132	3	45.5	1	383
-170-M 42	2				170	42	28	71	36.4		56		137	3.5	35.5	0.7	381
-195-M 67					195	67			39				162	3.6	45.9	0.9	384
-SLFB16- 90-M 22	1	16	32	8	90	22	39	—	34.3	42	—	32	58	2.4	26.5	0.4	385
 -110-M 42					110	42			36.4				78	2.5	34.8	0.5	388
-120-M 22					120	22	69		34.3				87	2.7	26.9		386
-135-M 67					135	67	39		39				103		45.2	0.7	388
-140-M 42					140	42	69		36.4				107	2.8	35.2		391
-150-M 22	2				150	22	28	71	34.3		56		117	3.4	27.2	0.5	387
-165-M 67	1				165	67	69	—	39		—		132	3	45.5	1	392
-170-M 42	2				170	42	28	71	36.4		56		137	3.5	35.5	0.7	390
-195-M 67					195	67			39				162	3.6	45.9	0.9	393
-SLSB16-165 CV	3	16	21	2.5	165	136	—	—	85	—	—	32	131	4.2	34.2	0.6	394
-195 CV					195	166							161	4	33.7	1.1	395
-225 CV					225	196							191	4.8	38.4	1.2	396
-255 CV					255	226							221	4.7	38	2	397
-285 CV					285	256							251	5.5	42.6		398
-315 CV					315	286							281	5.9	44.8	2.6	399
-345 CV					345	316							311	6.2	46.9	3.3	400
A100-SLSB5/8-165 CV	3	5/8	.82	.10	6.50	5.35	—	—	3.35	—	—	1.26	5.20	8.8	31.9	0.6	401
-195 CV					7.68	6.54							6.38	8.6	32.6	1.2	402
-225 CV					8.86	7.72							7.56	10.4	37.6		403
-255 CV					10.04	8.90							8.74	10.1	38.3	2.0	404
-285 CV					11.22	10.08							9.92	11.9	43.4	2.2	405
-315 CV					12.40	11.26							11.10	12.7	46.3	2.8	406
-345 CV					13.58	12.44							12.28	13.5	49.1	3.5	407
A100-SLSB20-110-M 42	1	20	29	4.5	110	42	39	—	33.4	42	—	40	78	2.5	37.4	0.6	408
-135-M 67					135	67			36				103	2.6	52.8	0.9	411
-140-M 42					140	42	69		33.4				107	2.7	37.8	0.8	409
-165-M 67					165	67			36				132	2.8	53.2	1.2	412
-M 97						97	39		39.2	53			133	2.9	71.3	1.1	414

CODE	Fig.	φD	φC	t	L	M	L ₁	L ₂	φC ₁	φC ₂	φC ₃	H	h	Kg lbs	N	S	Scale model
A100-SLSB20-170-M 42	2				170	42	28	71	33.4	42	56	40	137	3.4	38.1	0.8	410
-195-M 67					195	67			36				162	3.5	53.5	1.2	413
-M 97	1				97	69	—		39.2	53	—			3.3	71.7	1.3	415
-M127					127	39			42.3				163	3.2	91	1.5	417
-225-M 97	2				225	97	28	71	39.2		67		190	4.3	72	1.3	416
-M127	1				127	69	—		42.3		—			3.6	91.4	1.8	418
-M157					157	39			45.5				193	3.5	109.6	1.9	420
-255-M127	2				255	127	28	71	42.3		67		220	4.5	91.8	1.8	419
-M157	1				157	69	—		45.5		—			3.9	109.9	2.2	421
-285-M157	2				285		28	71			67		250	4.8	110.3		422
-SLRB20-110-M42	1	20	38	9	110	42	39	—	42.4	53	—	40	78	2.8	37.5	0.3	423
-135-M67					135	67			45				103	3.1	53	0.5	426
A100 -140-M42					140	42	69		42.4				105	3.2	37.9	0.4	424
-165-M67					165	67			45				130	3.5	53.3	0.6	427
-170-M42	2				170	42	28	71	42.4	53	67		135	4.1	38.2	0.4	425
-195-M67					195	67			45				160	4.4	53.7	0.6	428
-SLFB20-110-M42	1	20	38	9	110	42	39	—	42.4	53	—	40	78	2.8	37.5	0.3	429
 -135-M67					135	67			45				103	3.1	53	0.5	432
-140-M42					140	42	69		42.4				105	3.2	37.9	0.4	430
-165-M67					165	67			45				130	3.5	53.3	0.6	433
-170-M42	2				170	42	28	71	42.4		67		135	4.1	38.2	0.4	431
-195-M67					195	67			45				160	4.4	53.7	0.6	434
-SLSB20-165 CV	3	20	26	3	165	136	—	—	85	—	—	40	132	4	33.6	0.6	435
-195 CV					195	166							161	4.9	38.1	0.7	436
-225 CV					225	196							191	4.6	37.4	1.2	437
-255 CV					255	226							221	5.5	42.1	1.3	438
-285 CV					285	256							251	5.2	41.2	2.1	439
-315 CV					315	286							281	6.1	46	2.3	440
-345 CV					345	316							311	6.4	47.9	2.9	441
A100-SLSB3/4-165 CV	3	3/4	.99	.12	6.50	5.35	—	—	3.35	—	—	1.50	5.20	8.6	31.5	0.6	442
-195 CV					7.68	6.54							6.38	10.4	36.6	0.7	443
-225 CV					8.86	7.72							7.56	10.0	37.5	1.2	444
-255 CV					10.04	8.90							8.74	11.7	42.6	1.3	445
-285 CV					11.22	10.08							9.92	11.4	43.5	2.2	446
-315 CV					12.40	11.26							11.10	13.1	48.6	2.3	447
-345 CV					13.58	12.44							12.28	13.8	51.6	3.0	448
A100-SLRB25-110-M42	1	25	45	10	110	42	39	—	49.4	53	—	45	78	2.9	40.7	0.3	449
-140-M42					140		69						105	3.3	41	0.4	450
-170-M42	2				170		28	71			67		135	4.2	41.4		451
-SLFB25-110-M42	1	25	45	10	110	42	39	—	49.4	53	—	45	78	2.9	40.7	0.3	452
 -140-M42					140		69						105	3.3	41	0.4	453
-170-M42	2				170		28	71			67		135	4.2	41.4		454
A100-SLRB32-110-M42	1	32	54	11	110	42	39	—	58.4	63	—	50	77	3.2	26.9	0.2	455
-140-M42					140		69						107	3.7	33.4	0.3	456
-170-M42	2				170		28	71			77		132	4.9	42.8		457

Cleaning tool for a spindle taper hole, STAR DUST

CODE
CLT-A100-G3

P.226



φ70 Nozzle(HRB-03S)

Required for shrinking the SLRB32.

CODE
HRB-NZL70

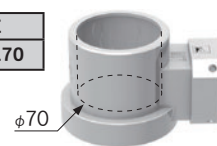

HEAT ROBO Baby 3000S

φ 3

Feature

Shrink-fit Heater

MONO 3° MONO CURVE

MONO Series

2PIECE type

UNO

HYPER version

STRAIGHT anbor

OTHERS

PERIPHERALS

Technical Information

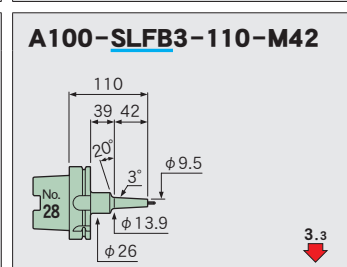
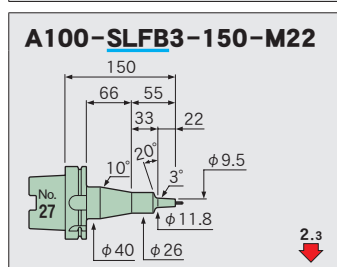
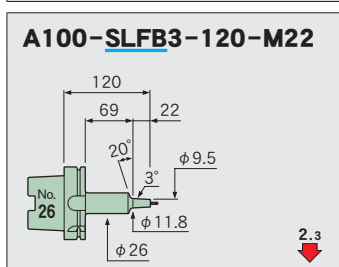
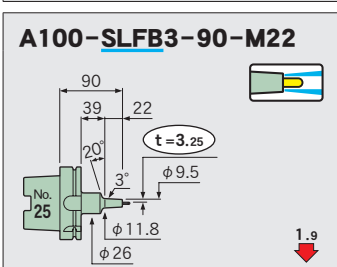
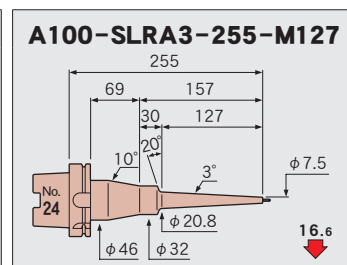
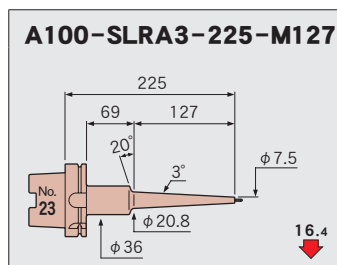
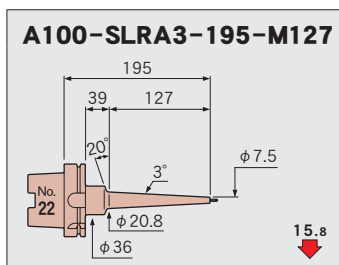
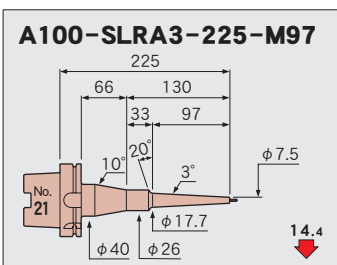
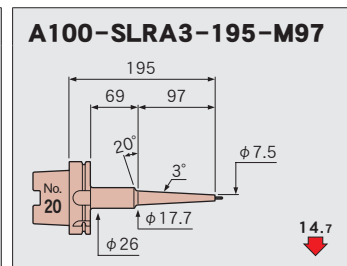
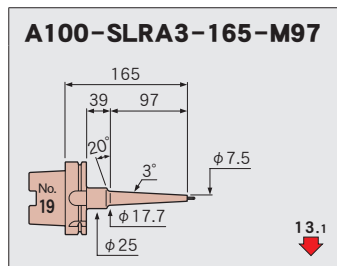
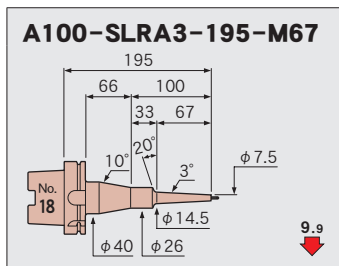
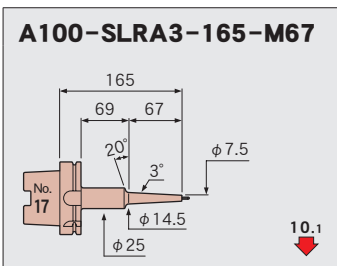
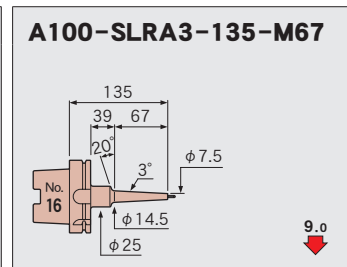
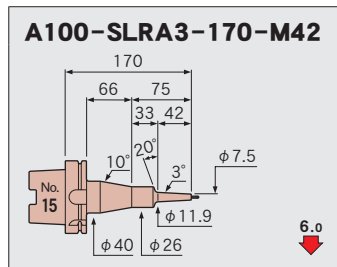
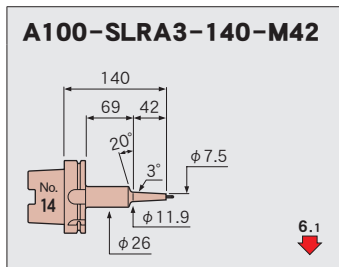
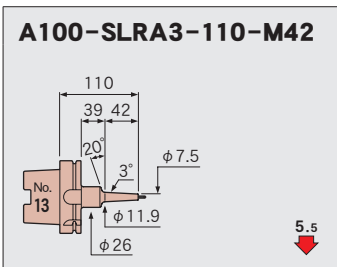
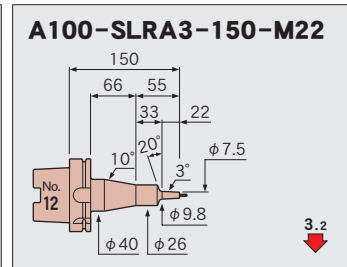
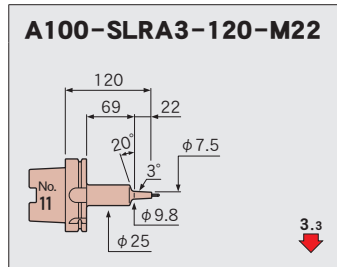
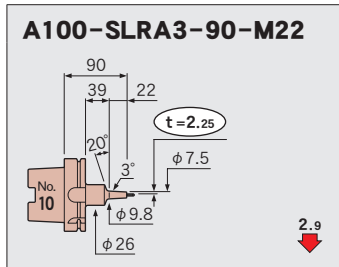
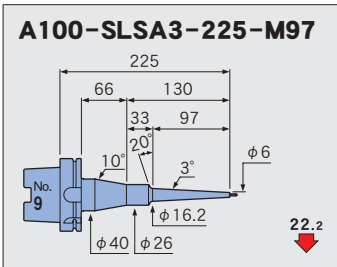
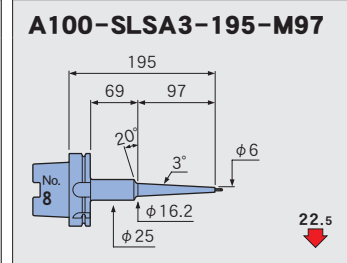
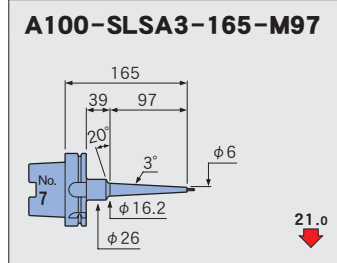
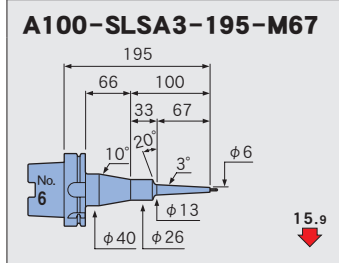
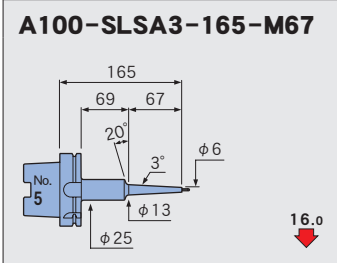
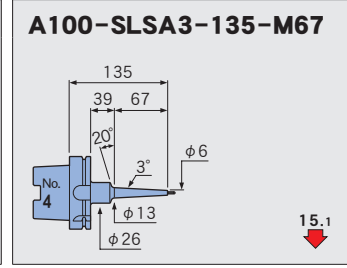
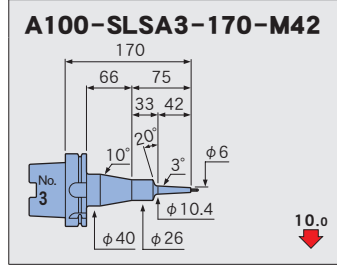
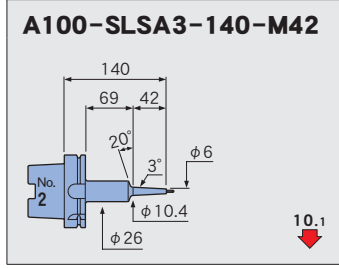
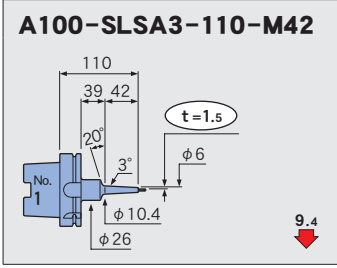

A100-SLFB3-140-M42

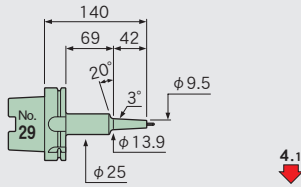

A100-SLFB3-170-M42

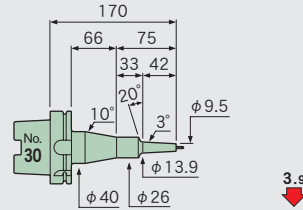

A100-SLFB3-135-M67

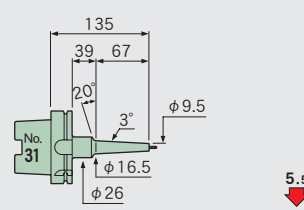

A100-SLFB3-165-M67

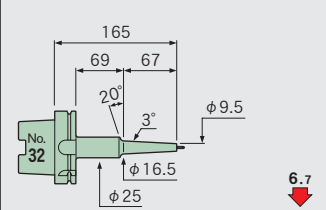

A100-SLFB3-195-M67

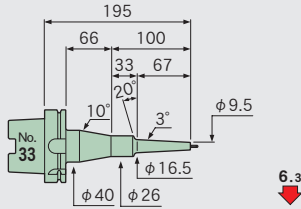

φ 4

A100-SLSA4-110-M42

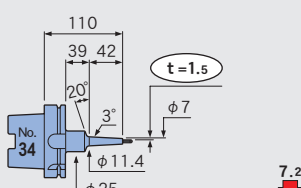

A100-SLSA4-140-M42

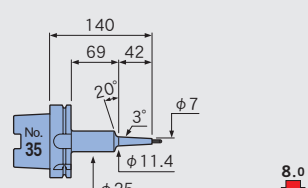

A100-SLSA4-170-M42

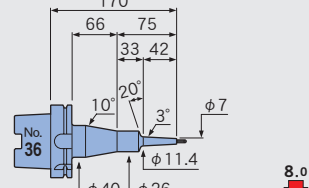

A100-SLSA4-135-M67

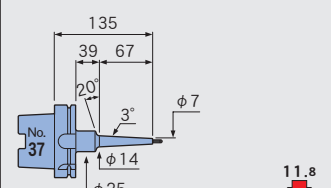

A100-SLSA4-165-M67

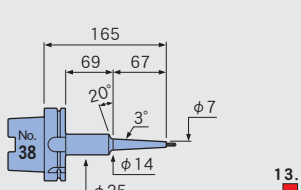

A100-SLSA4-195-M67

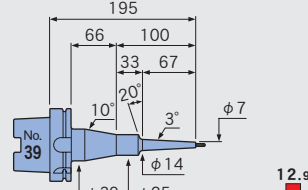

A100-SLSA4-165-M97

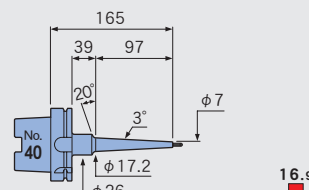

A100-SLSA4-195-M97

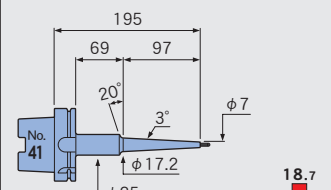

A100-SLSA4-225-M97

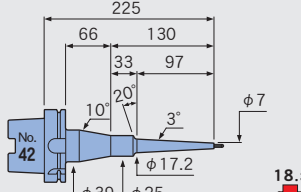

A100-SLRA4-90-M22

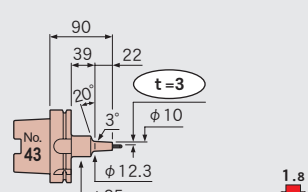

A100-SLRA4-120-M22

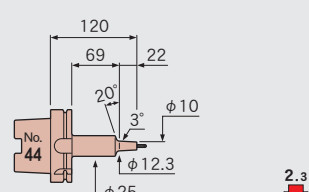

A100-SLRA4-150-M22

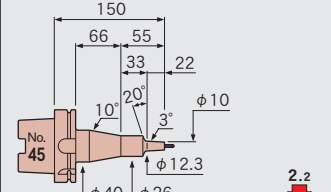

A100-SLRA4-110-M42

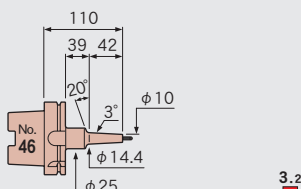

A100-SLRA4-140-M42

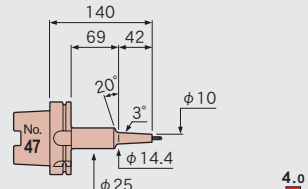

A100-SLRA4-170-M42

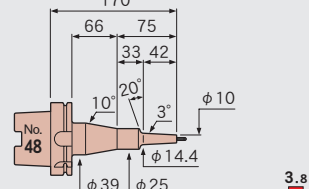

A100-SLRA4-135-M67

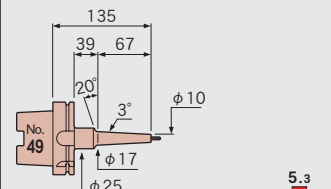

Shrink-fit Heater

MONO 3°
MONO CURVE

MONO Series

2PIECE type

UNO

HYPER
version

STRAIGHT
arbor

OTHERS

PERIPHERALS

Technical
Information

Feature
Shrink-fit Heater
MONO 3° MONO CURVE
MONO Series
2PIECE type
UNO
HYPER version
STRAIGHT anbor
OTHERS
PERIPHERALS
Technical Information

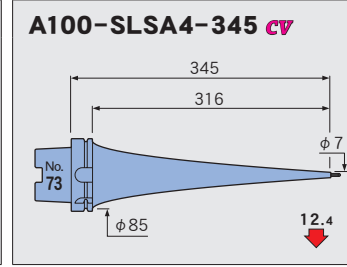
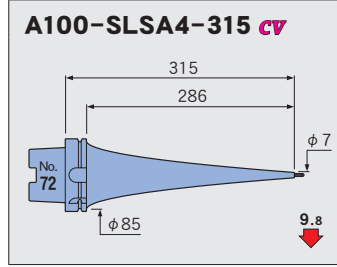
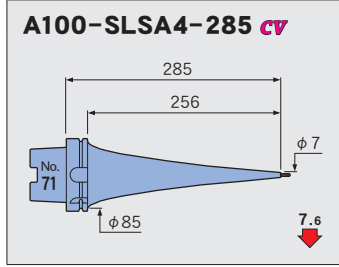
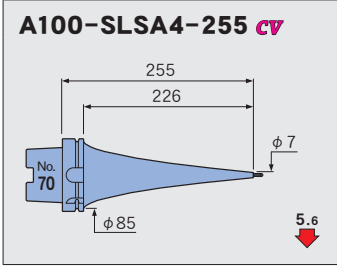
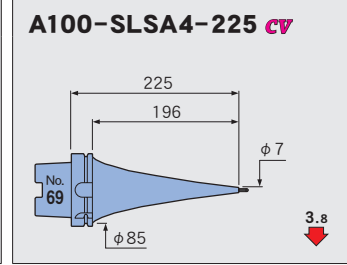
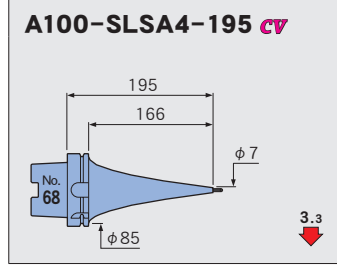
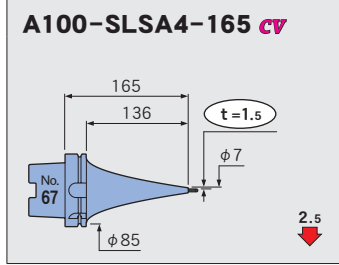
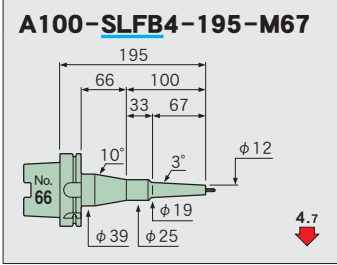
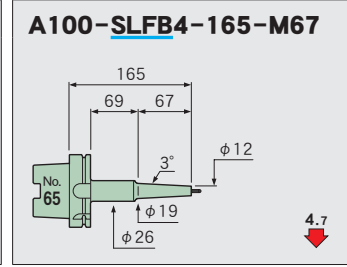
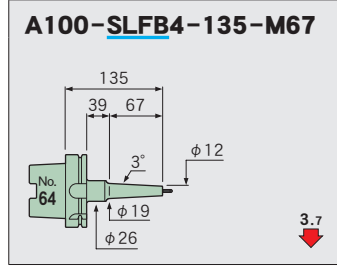
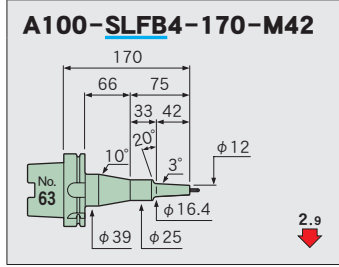
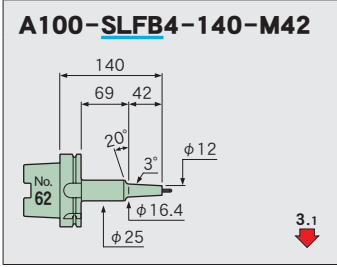
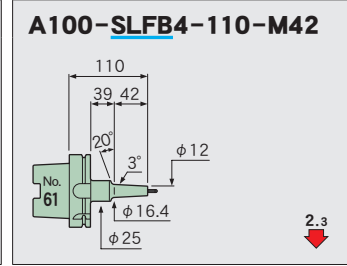
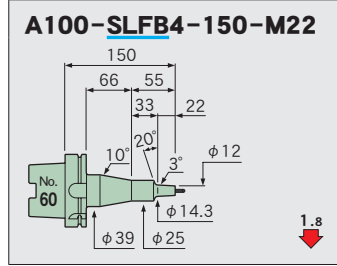
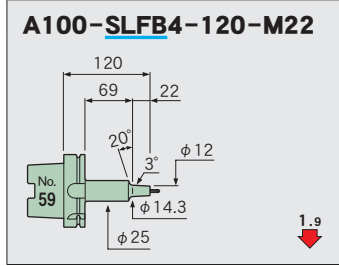
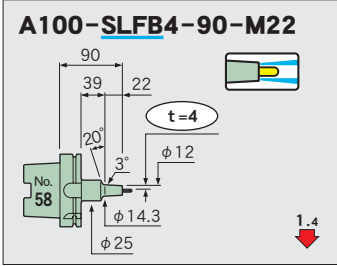
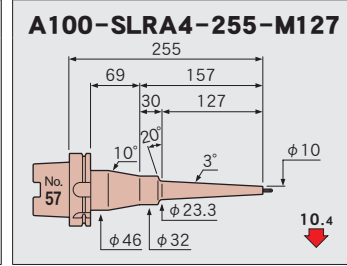
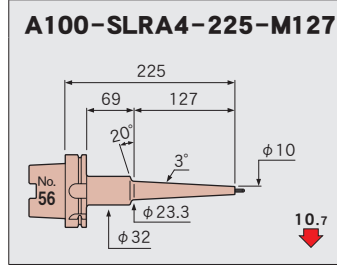
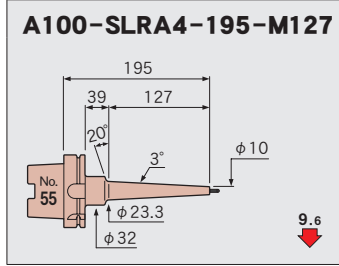
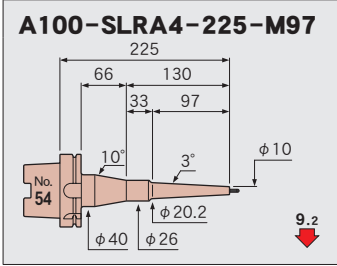
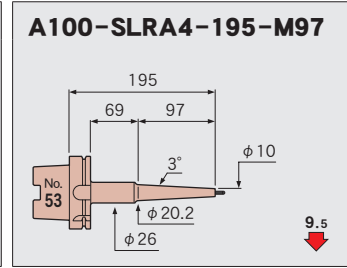
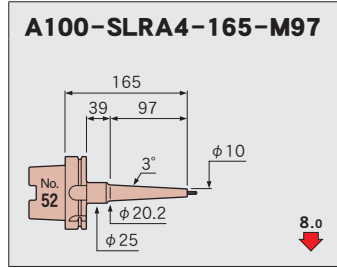
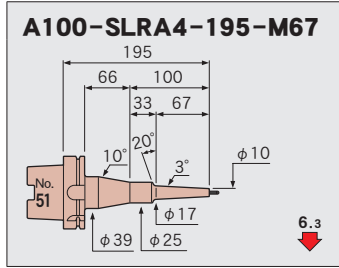
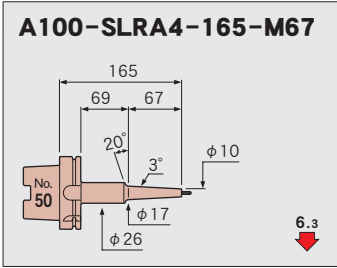

$\phi 3/16$

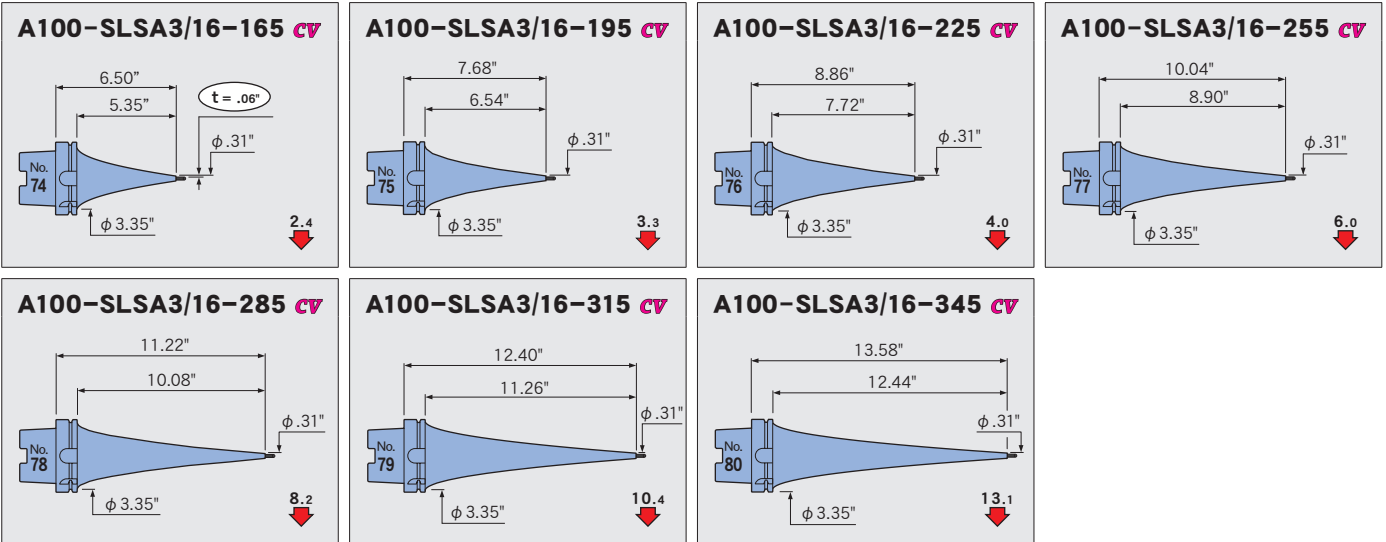

$\phi 6$

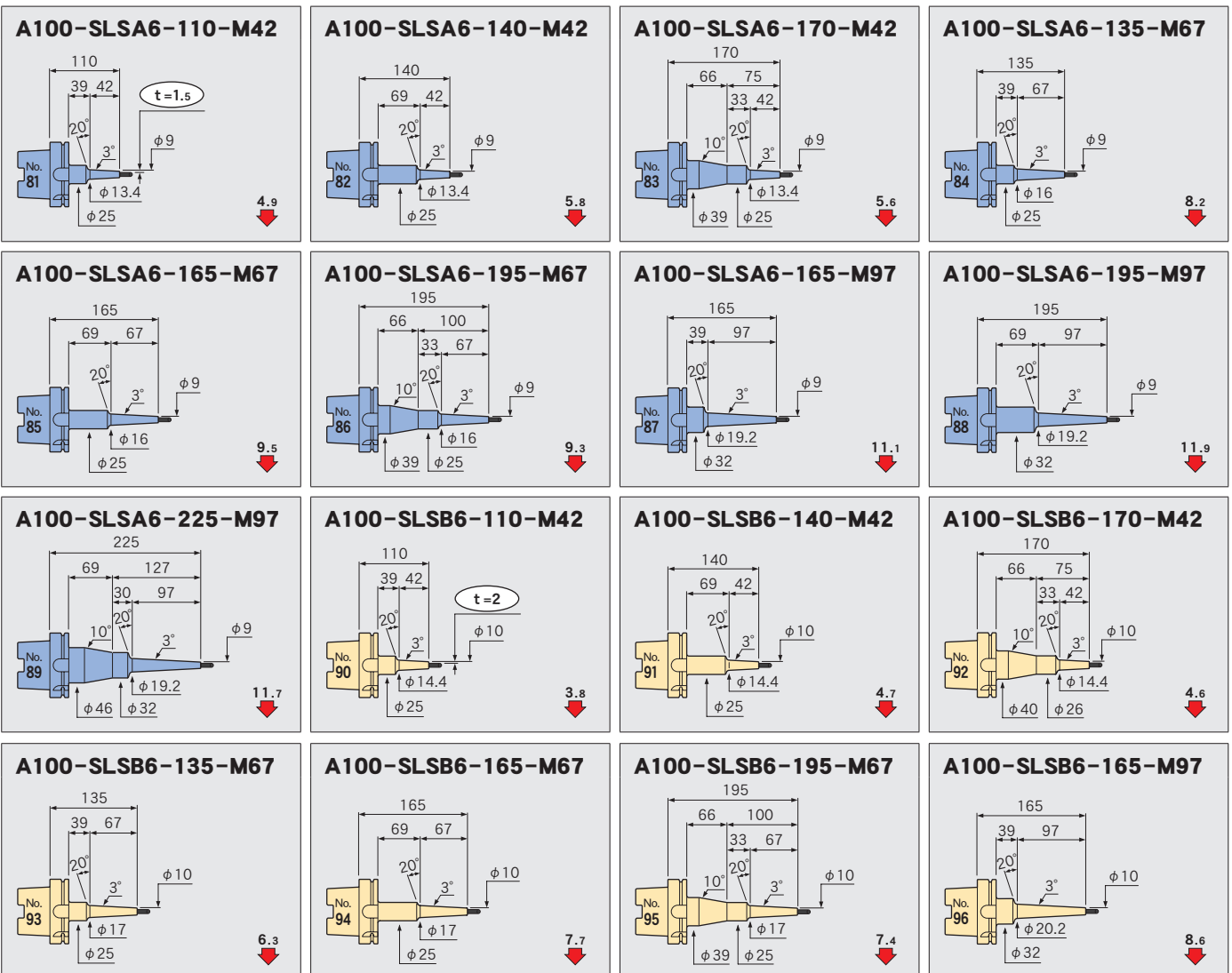

Feature

Shrink-fit Heater

MONO 3°
MONO CURVE

MONO Series

2PIECE type

UNO

HYPER
version

STRAIGHT
arbor

OTHERS

PERIPHERALS

Technical
Information

Feature
Shrink-fit Heater
MONO 3° MONO CURVE
MONO Series
2PIECE type
UNO
HYPER version
STRAIGHT arbor
OTHERS
PERIPHERALS
Technical Information

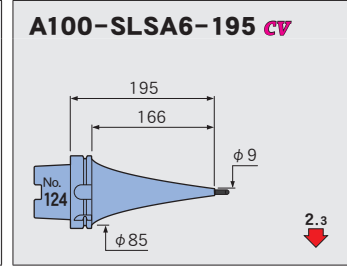
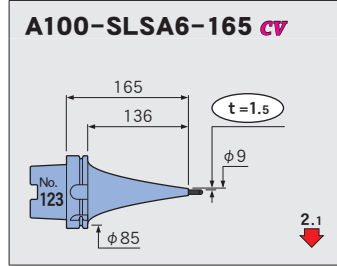
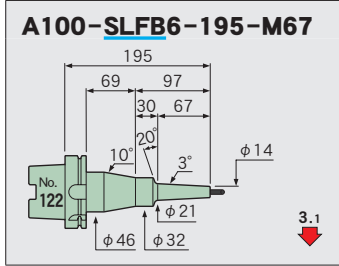
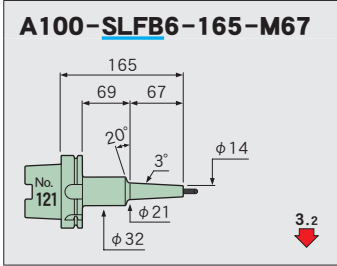
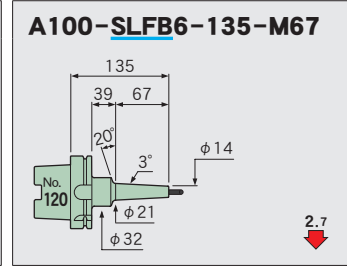
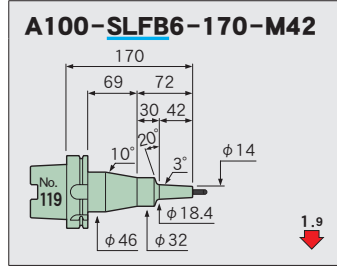
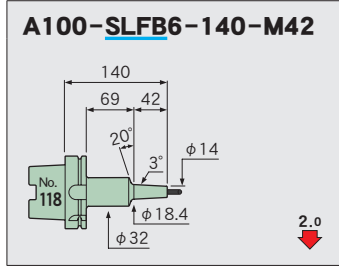
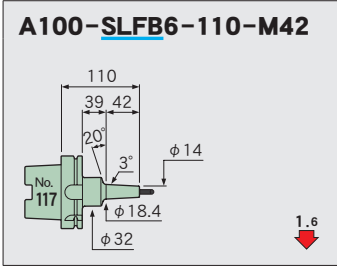
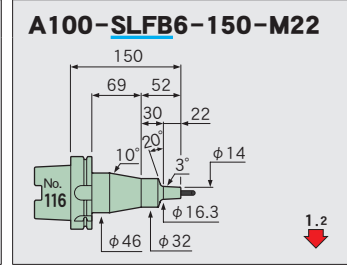
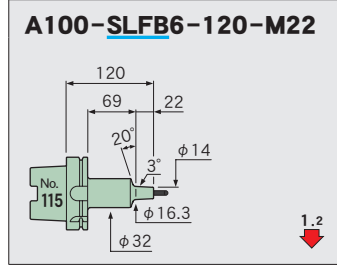
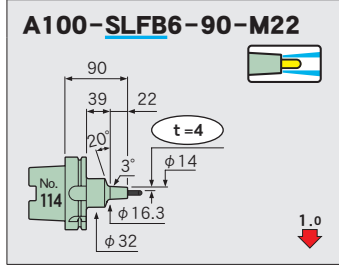
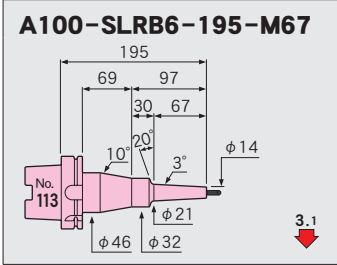
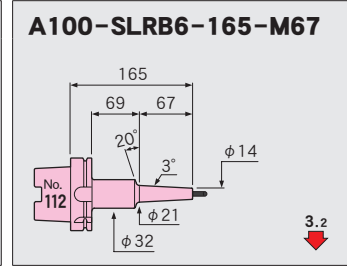
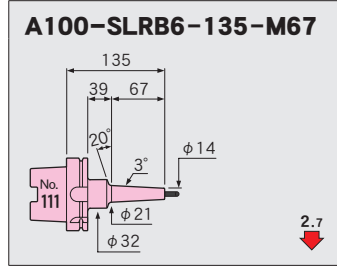
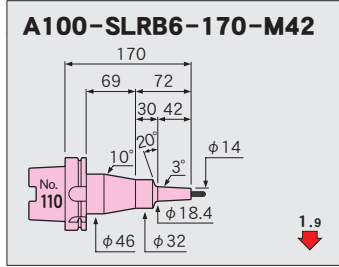
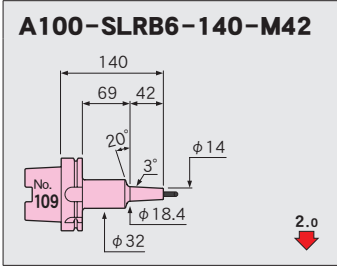
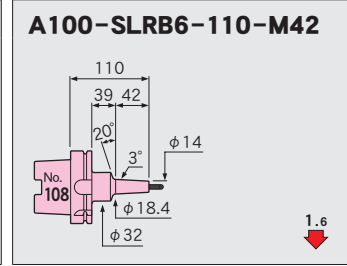
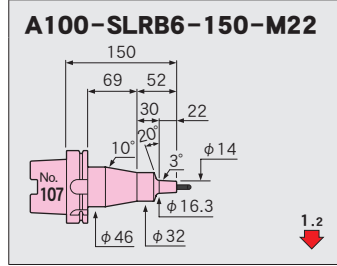
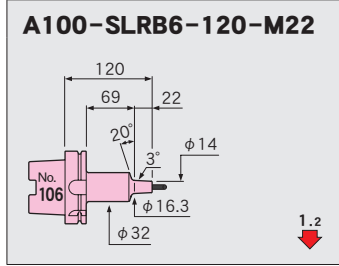
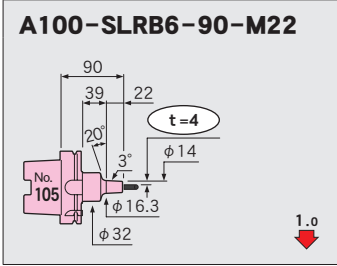
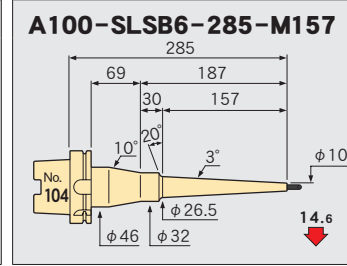
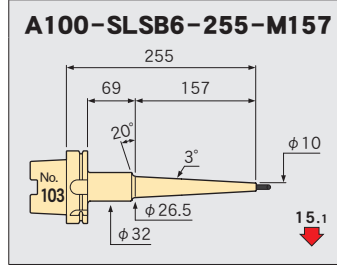
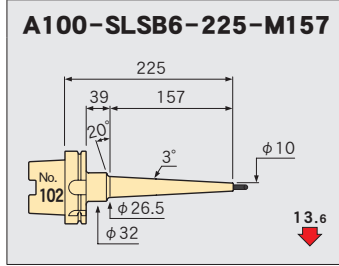
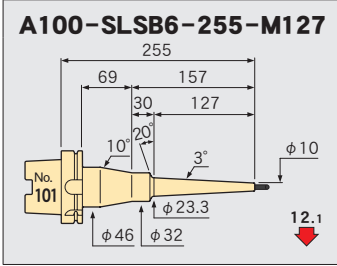
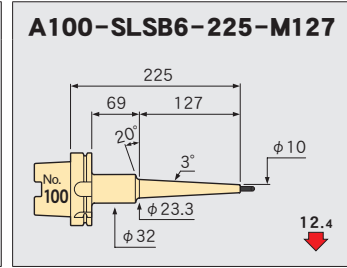
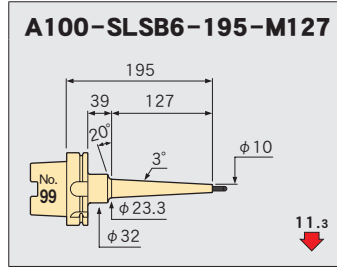
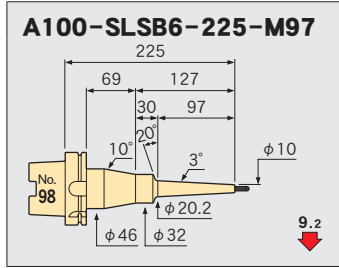
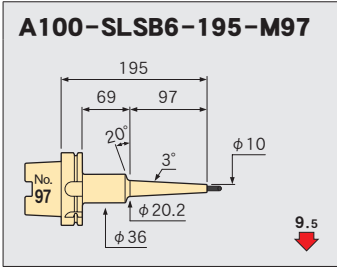

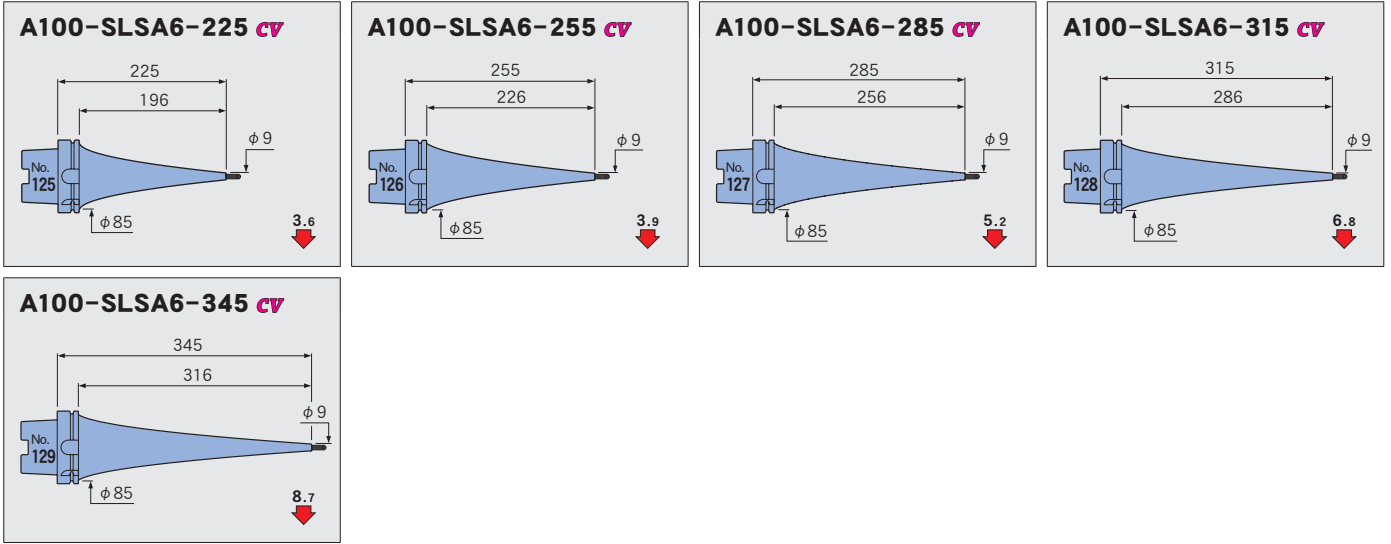

φ 1/4

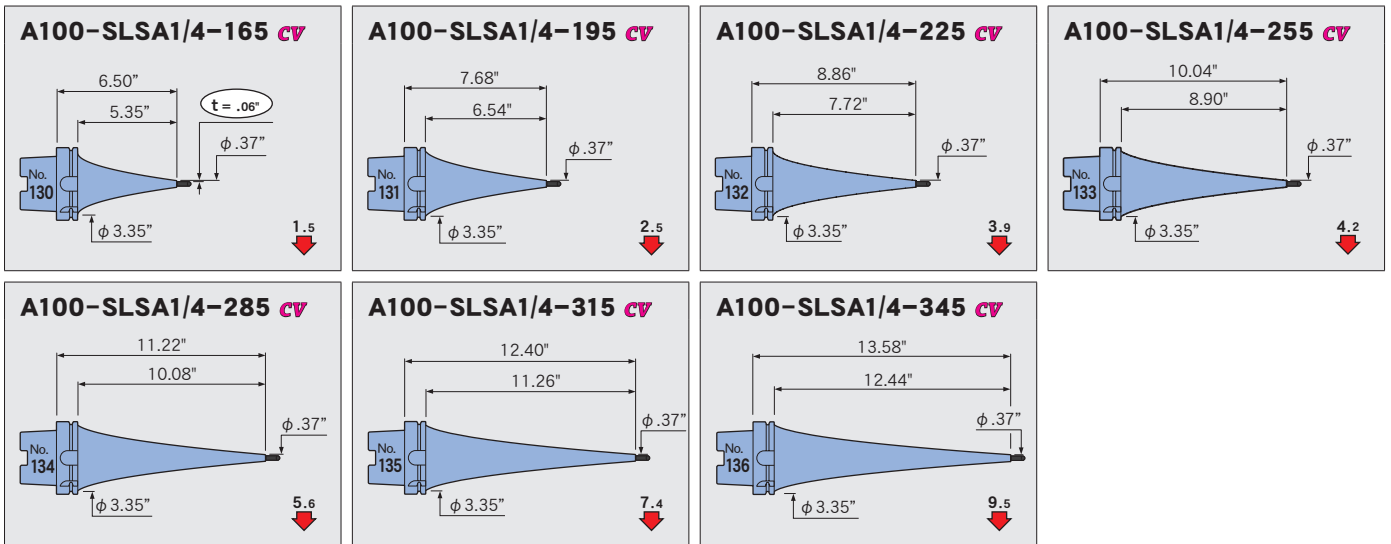

φ 8

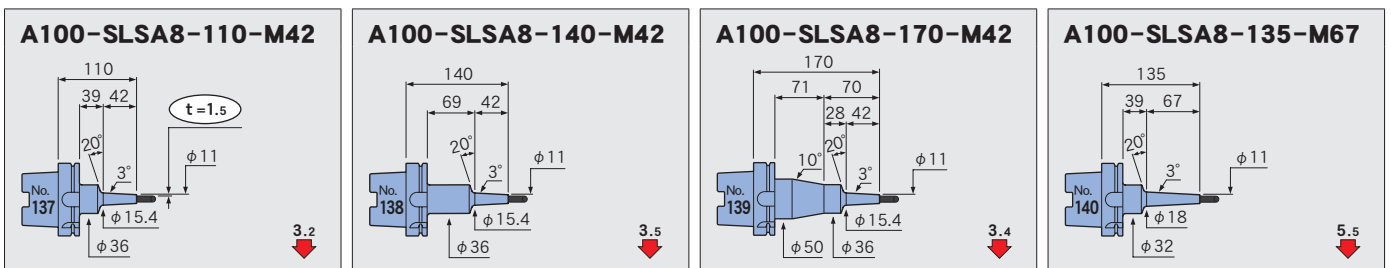

Feature
Shrink-fit Heater

MONO 3°
MONO CURVE

MONO Series

2PIECE type

UNO

HYPER
version

STRAIGHT
arbor

OTHERS

PERIPHERALS

Technical
Information

Feature
Shrink-fit Heater
MONO 3° MONO CURVE
MONO Series
2PIECE type
UNO
HYPER version
STRAIGHT arbor
OTHERS
PERIPHERALS
Technical Information

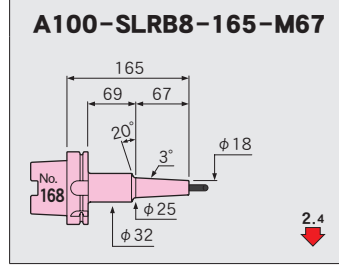
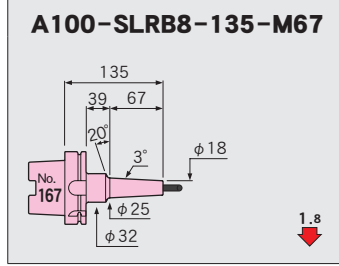
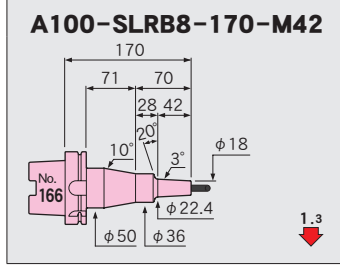
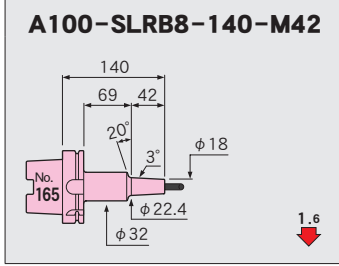
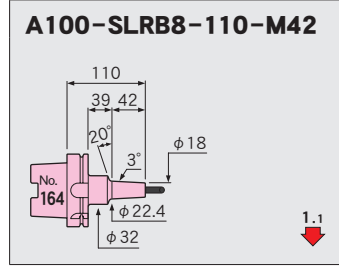
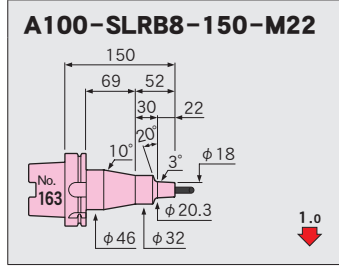
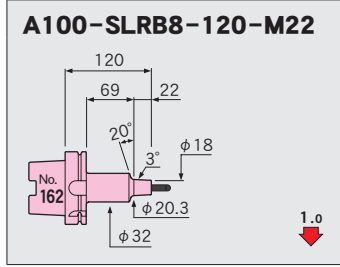
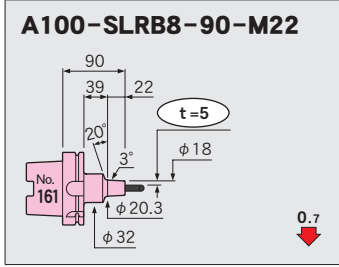
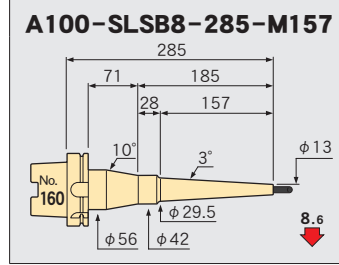
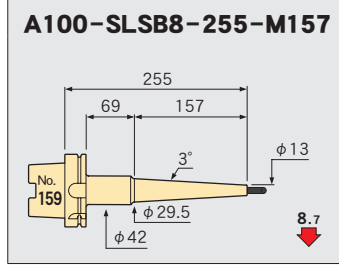
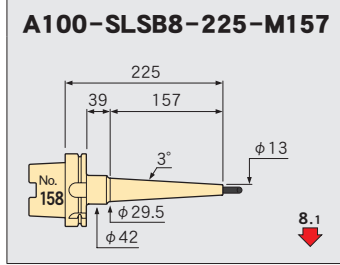
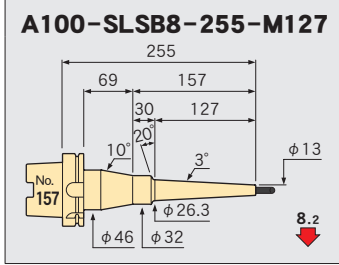
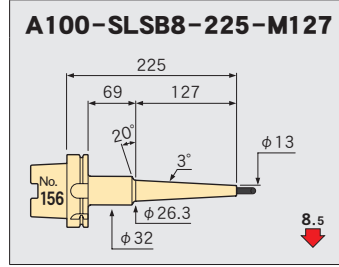
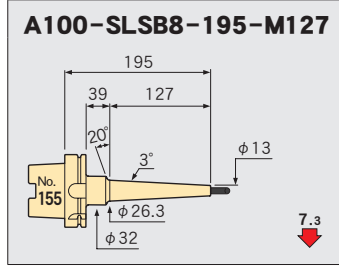
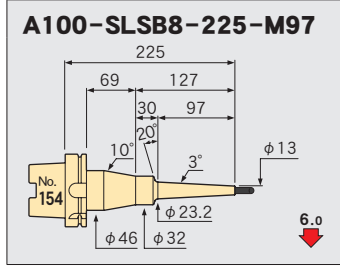
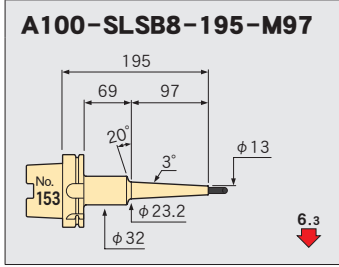
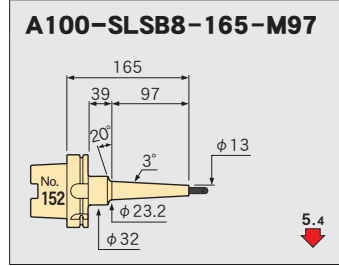
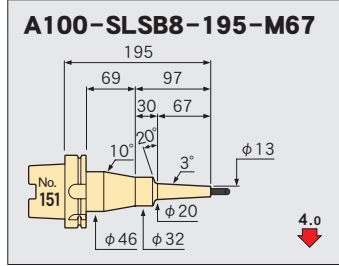
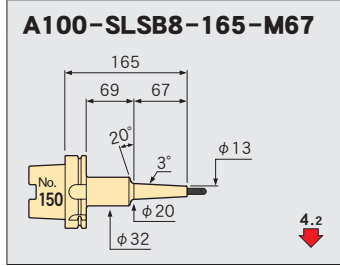
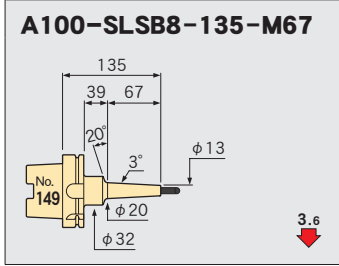
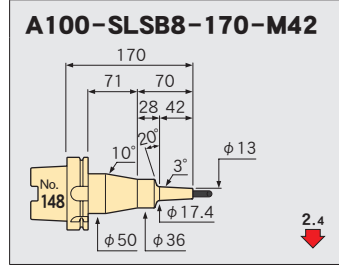
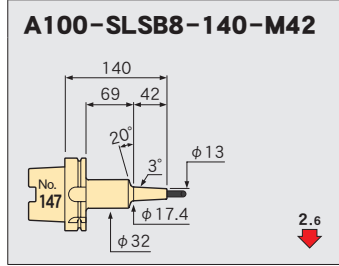
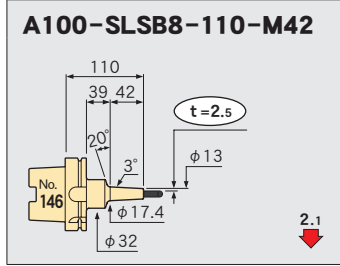
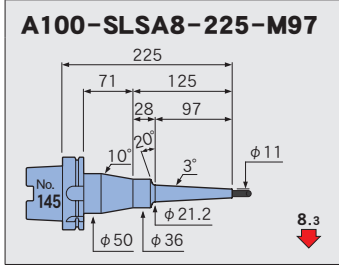
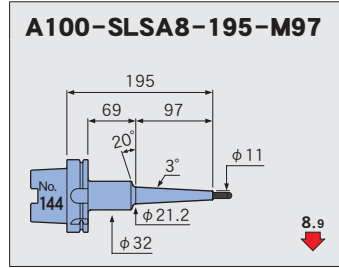
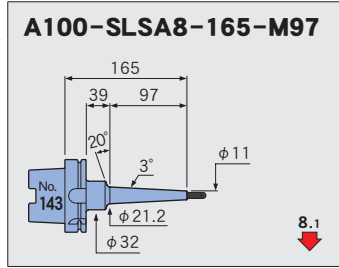
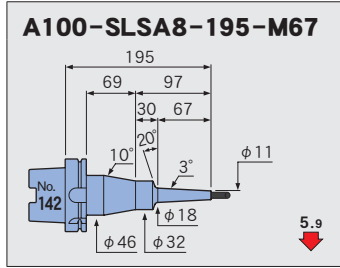
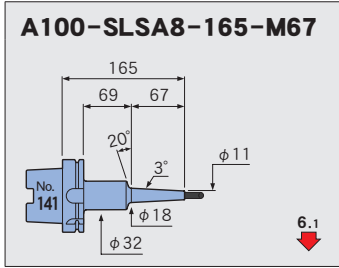

<p>A100-SLRB8-195-M67</p>	<p>A100-SLFB8-90-M22</p>	<p>A100-SLFB8-120-M22</p>	<p>A100-SLFB8-150-M22</p>
<p>A100-SLFB8-110-M42</p>	<p>A100-SLFB8-140-M42</p>	<p>A100-SLFB8-170-M42</p>	<p>A100-SLFB8-135-M67</p>
<p>A100-SLFB8-165-M67</p>	<p>A100-SLFB8-195-M67</p>	<p>A100-SLSA8-165 CV</p>	<p>A100-SLSA8-195 CV</p>
<p>A100-SLSA8-225 CV</p>	<p>A100-SLSA8-255 CV</p>	<p>A100-SLSA8-285 CV</p>	<p>A100-SLSA8-315 CV</p>
<p>A100-SLSA8-345 CV</p>	<p>A100-SLRA8-195 CV</p>	<p>A100-SLRA8-225 CV</p>	<p>A100-SLRA8-255 CV</p>
<p>A100-SLRA8-285 CV</p>	<p>A100-SLFA8-195 CV</p>	<p>A100-SLFA8-225 CV</p>	<p>A100-SLFA8-255 CV</p>
<p>A100-SLFA8-285 CV</p>			

Feature
Shrink-fit Heater

MONO 3°
MONO CURVE

MONO Series

2PIECE type

UNO

HYPER
version

STRAIGHT
arbor

OTHERS

PERIPHERALS

Technical
information

$\phi 5/16$

Feature

Shrink-fit Heater

MONO 3° MONO CURVE

MONO Series

2PIECE type

UNO

HYPER version

STRAIGHT anbor

OTHERS

PERIPHERALS

Technical Information

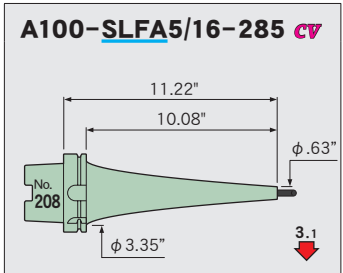
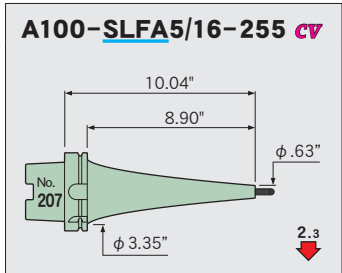
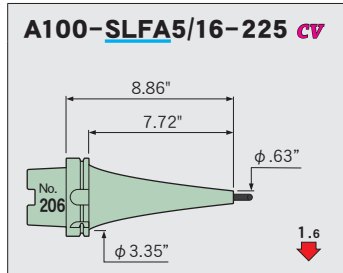
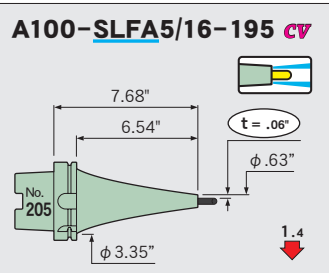
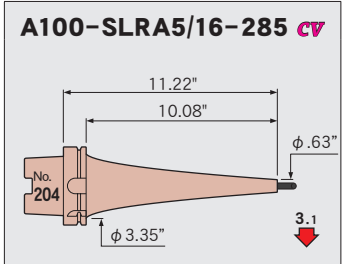
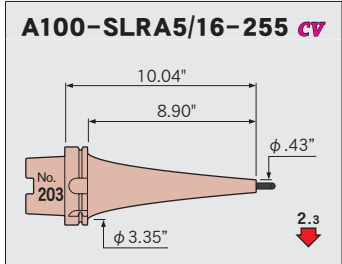
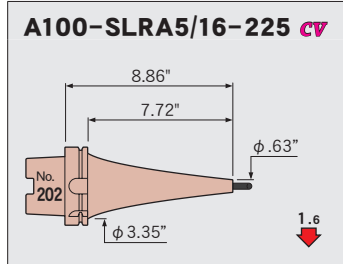
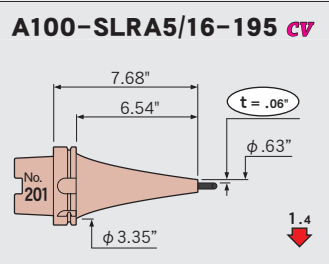
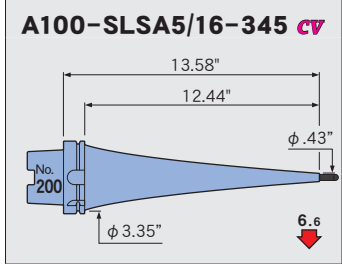
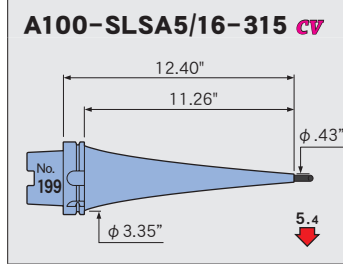
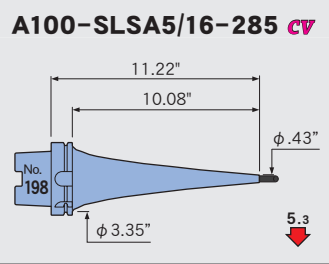
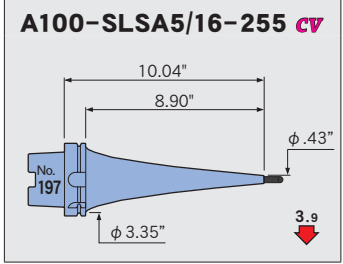
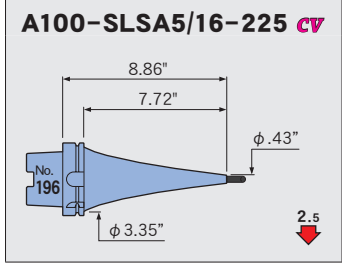
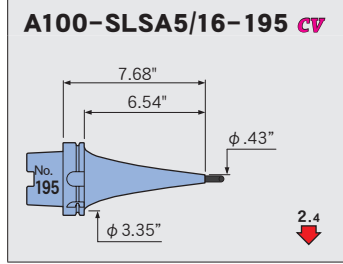
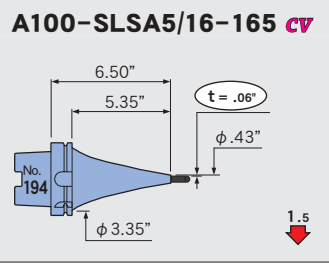

$\phi 10$

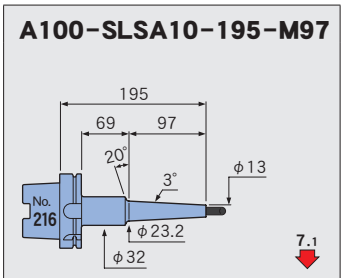
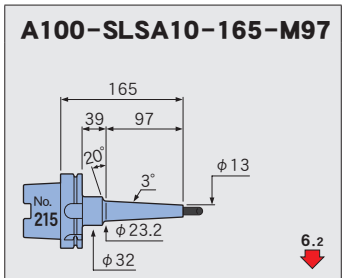
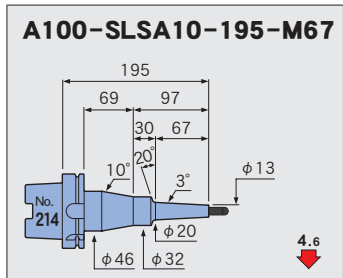
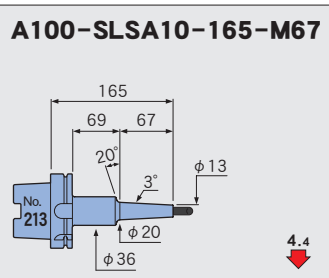
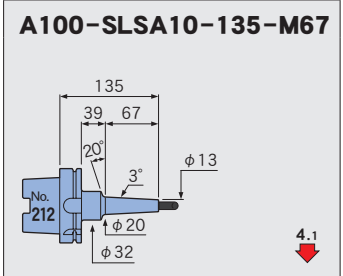
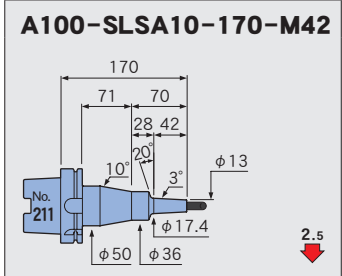
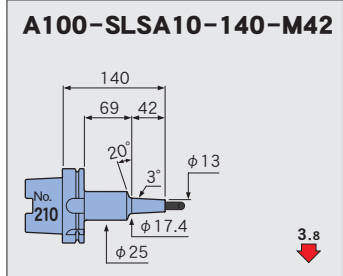
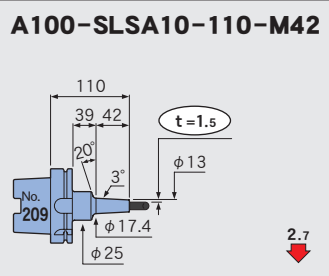

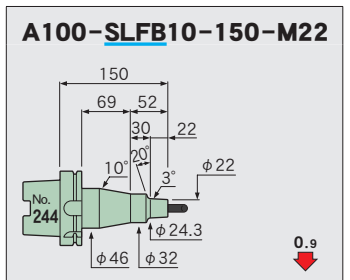
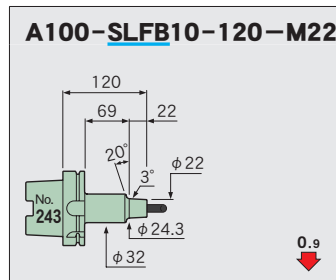
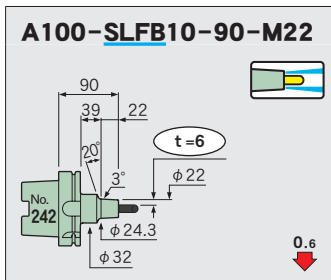
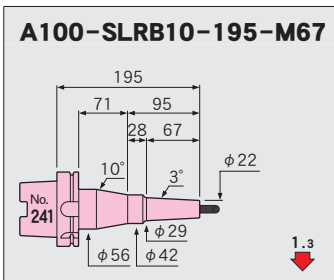
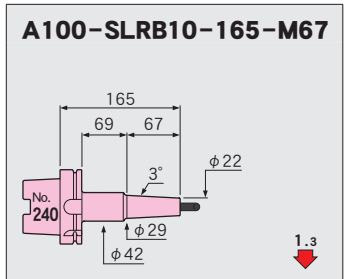
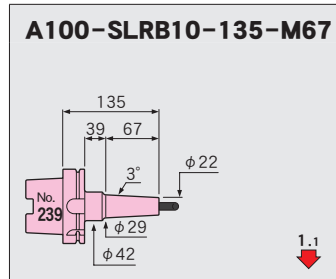
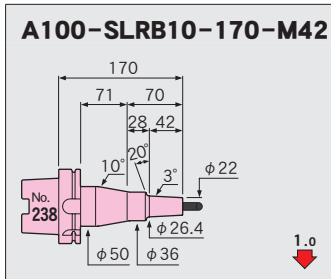
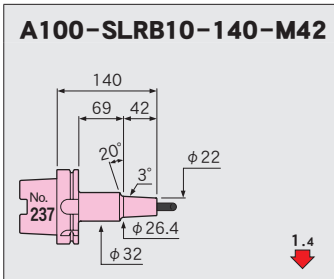
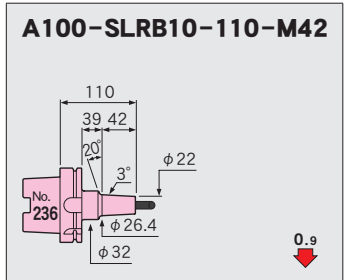
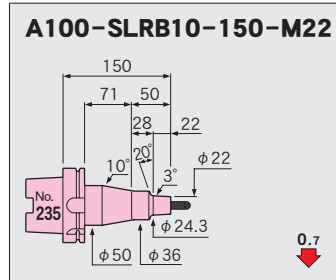
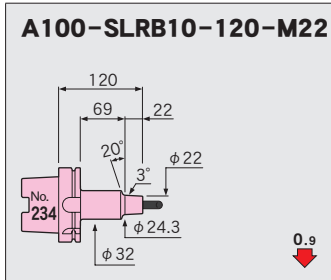
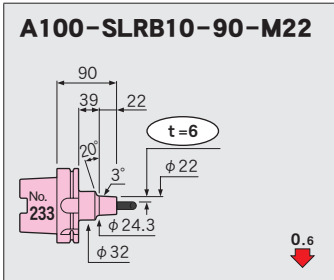
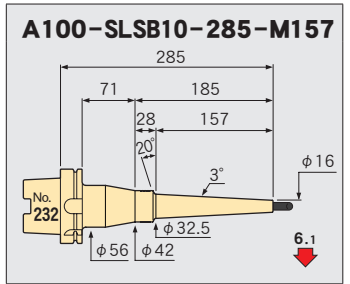
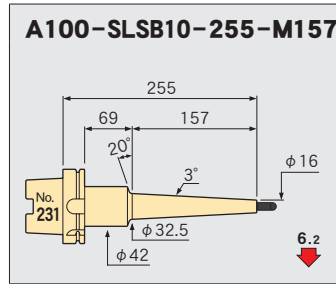
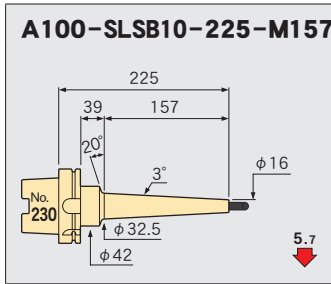
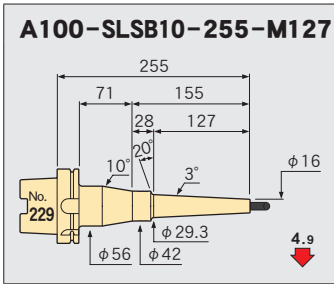
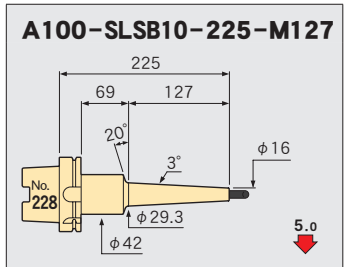
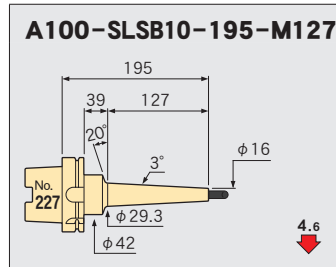
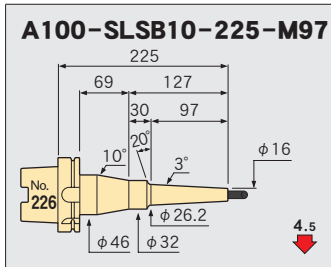
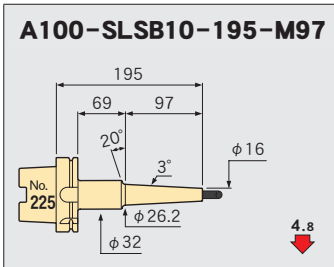
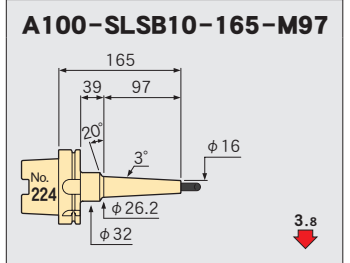
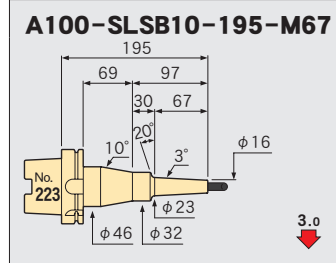
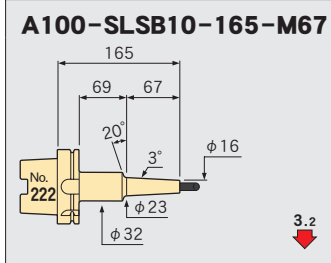
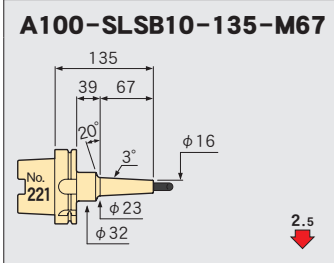
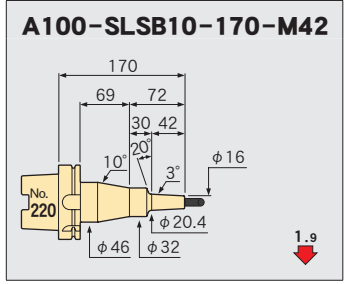
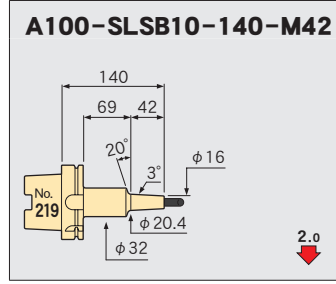
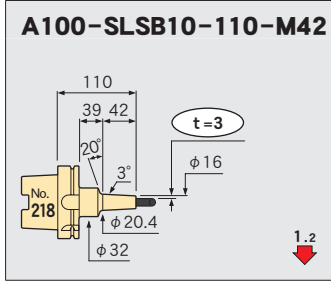
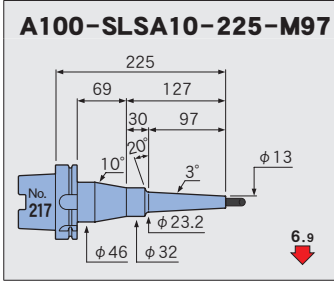

Feature

Shrink-fit Heater

MONO 3°
MONO CURVE

MONO Series

2PIECE type

UNO

HYPER
version

STRAIGHT
arbor

OTHERS

PERIPHERALS

Technical
Information

Feature

Shrink-fit Heater

MONO 3°
MONO CURVE

MONO Series

2PIECE type

UNO

HYPER
version

STRAIGHT
anbor

OTHERS

PERIPHERALS

Technical
Information

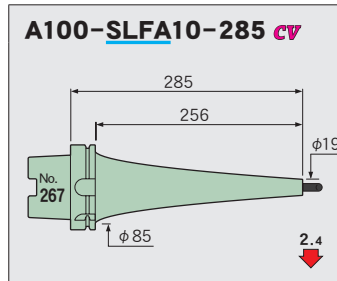
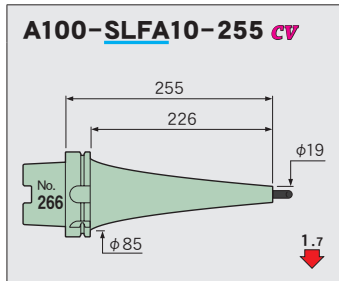
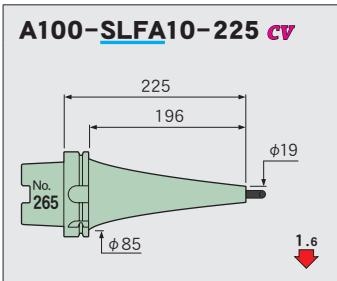
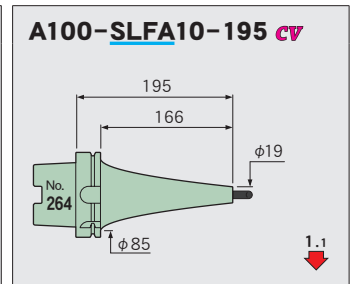
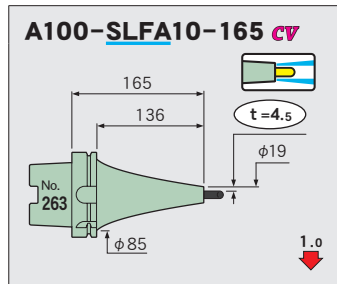
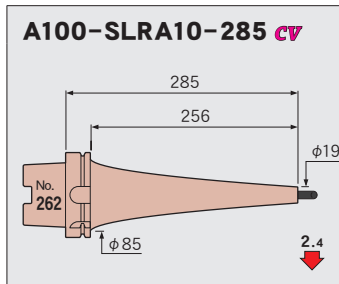
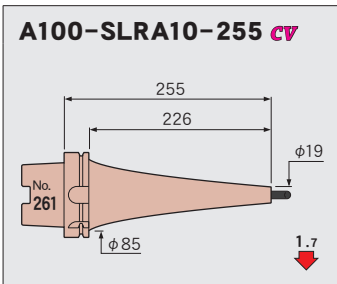
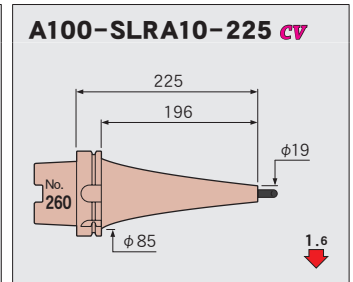
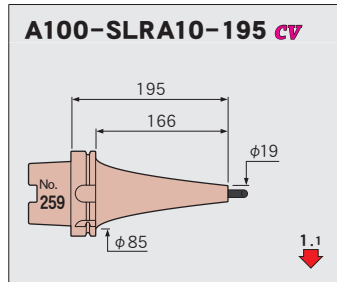
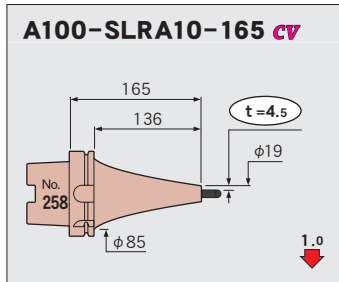
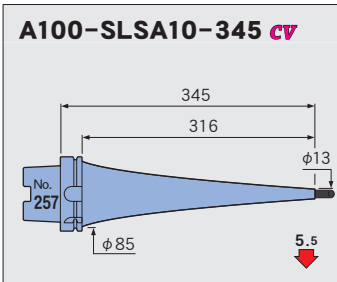
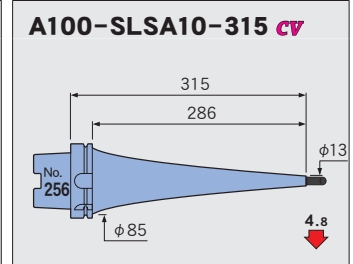
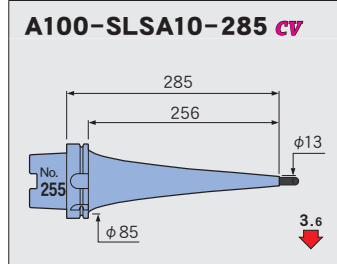
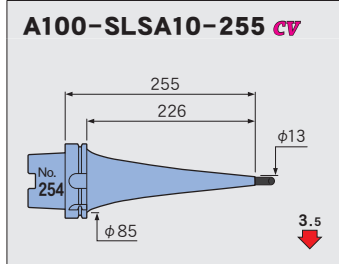
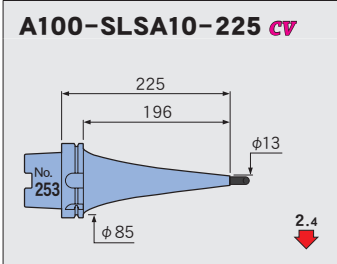
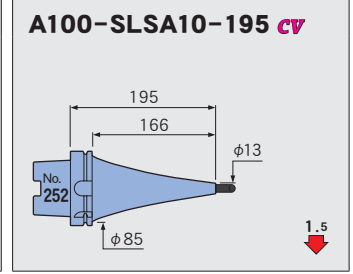
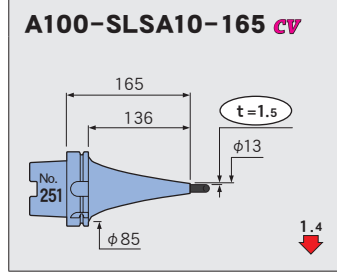
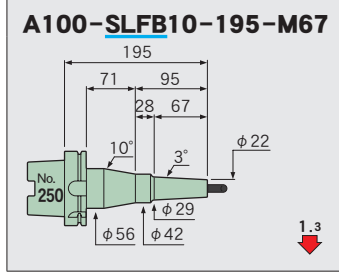
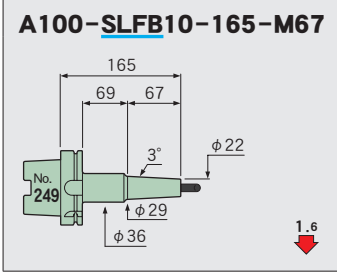
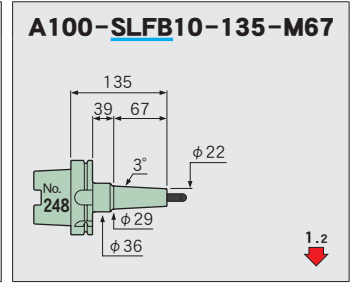
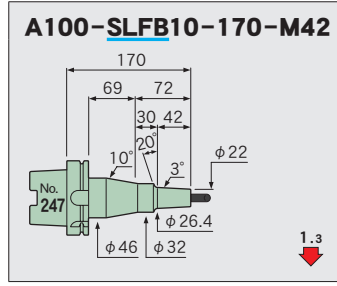
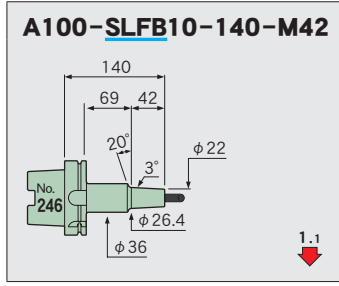
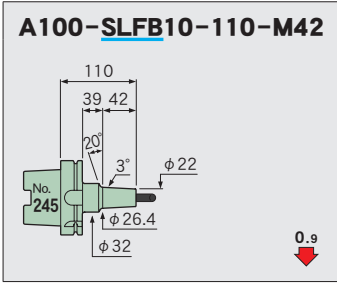

ϕ 3/8

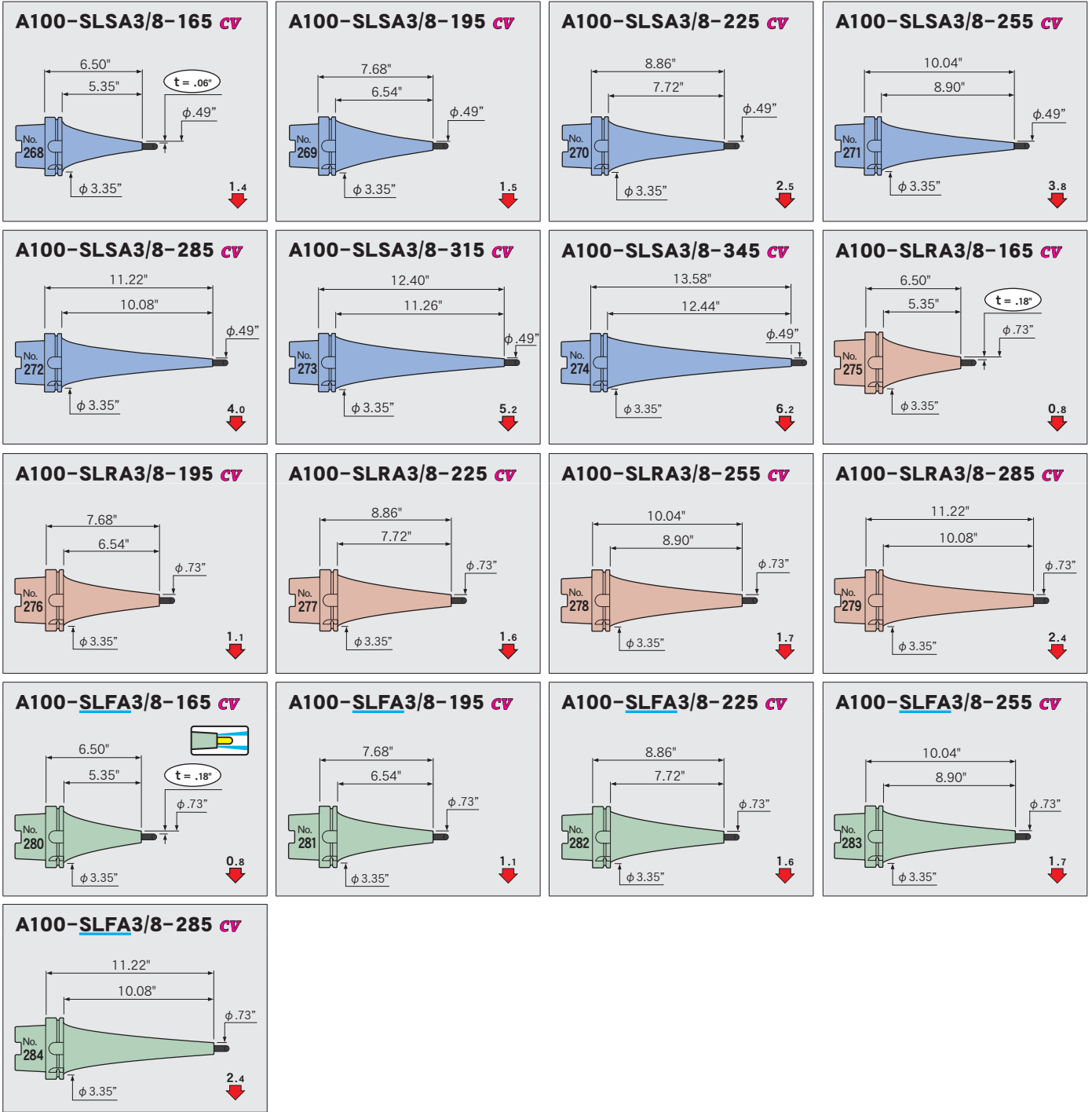

Feature
Shrink-fit Heater

MONO 3°
MONO CURVE

MONO Series

2PIECE type

UNO

HYPER
version

STRAIGHT
arbor

OTHERS

PERIPHERALS

Technical
Information

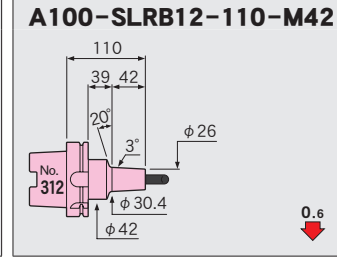
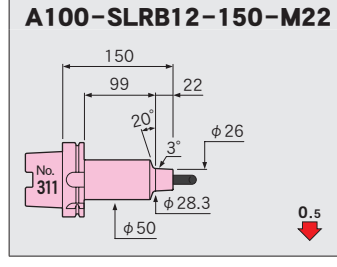
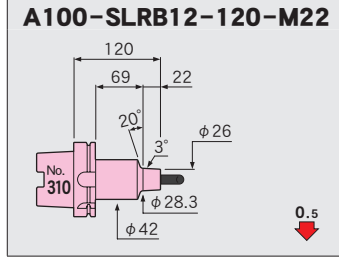
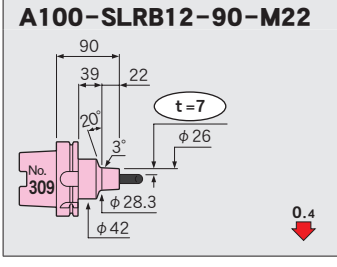
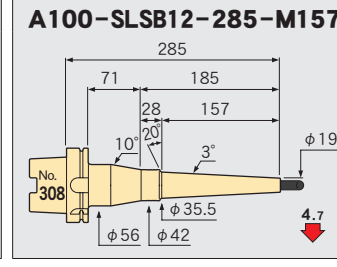
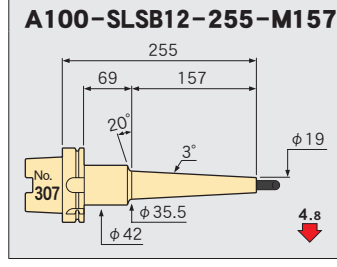
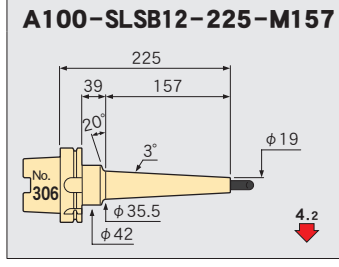
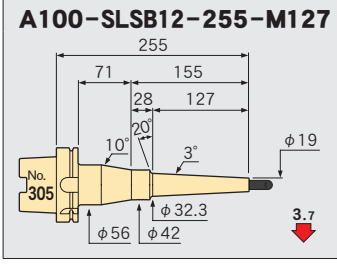
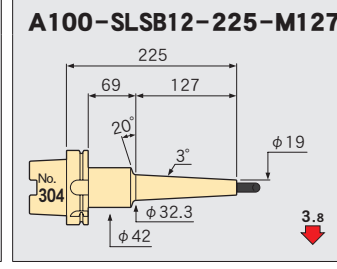
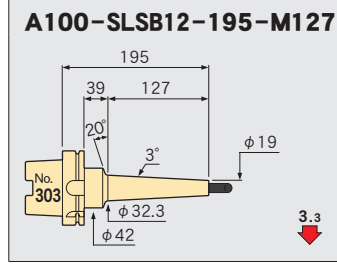
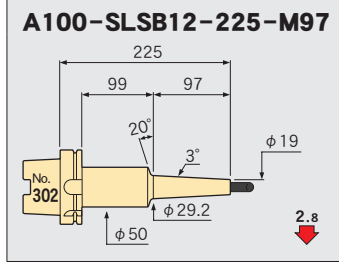
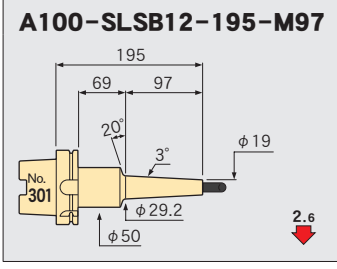
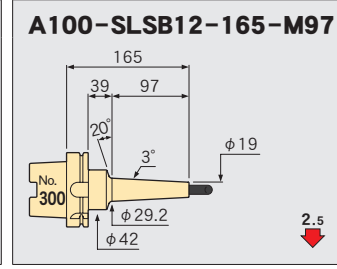
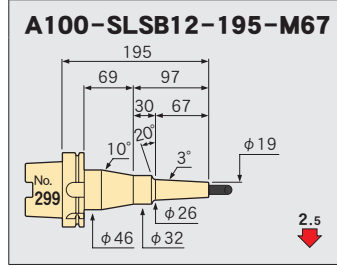
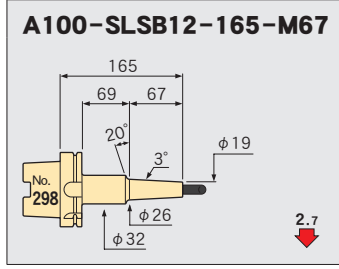
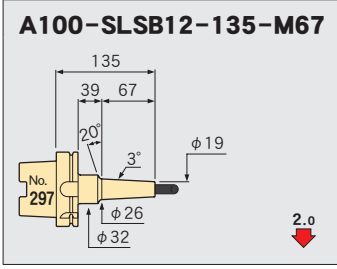
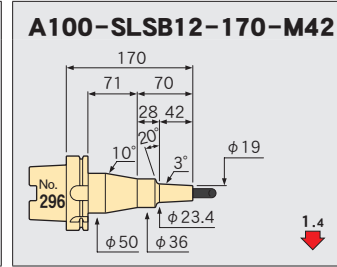
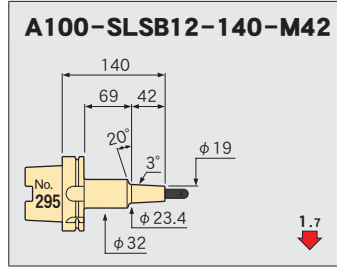
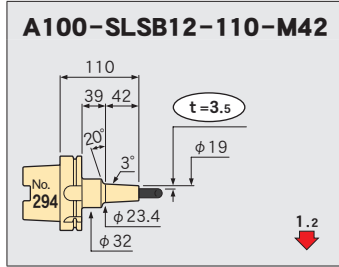
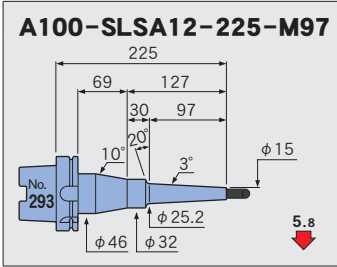
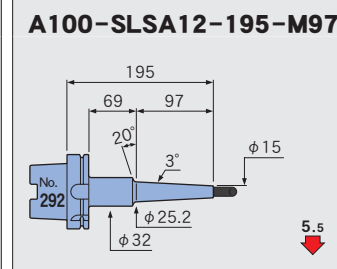
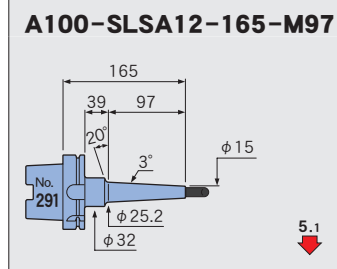
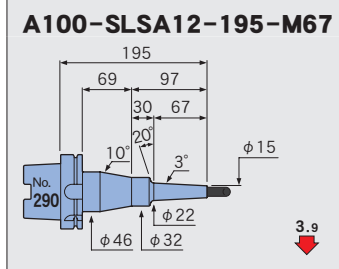
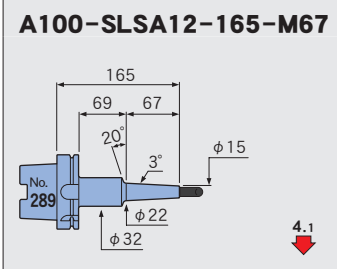
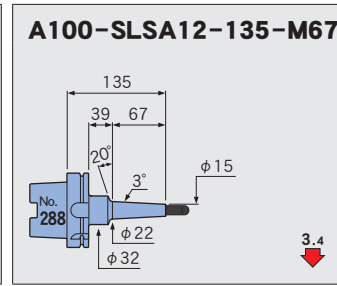
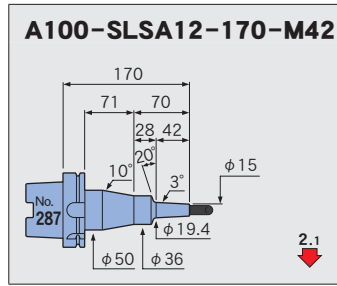
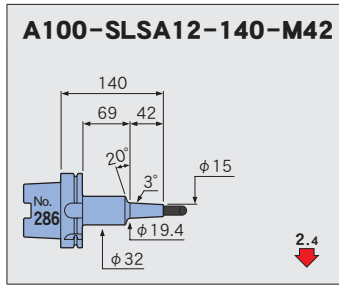
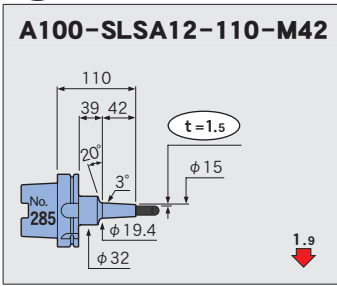

<p>A100-SLRB12-140-M42</p>	<p>A100-SLRB12-170-M42</p>	<p>A100-SLRB12-135-M67</p>	<p>A100-SLRB12-165-M67</p>
<p>A100-SLRB12-195-M67</p>	<p>A100-SLFB12-90-M22</p>	<p>A100-SLFB12-120-M22</p>	<p>A100-SLFB12-150-M22</p>
<p>A100-SLFB12-110-M42</p>	<p>A100-SLFB12-140-M42</p>	<p>A100-SLFB12-170-M42</p>	<p>A100-SLFB12-135-M67</p>
<p>A100-SLFB12-165-M67</p>	<p>A100-SLFB12-195-M67</p>	<p>A100-SLSA12-165 CV</p>	<p>A100-SLSA12-195 CV</p>
<p>A100-SLSA12-225 CV</p>	<p>A100-SLSA12-255 CV</p>	<p>A100-SLSA12-285 CV</p>	<p>A100-SLSA12-315 CV</p>
<p>A100-SLSA12-345 CV</p>	<p>A100-SLRA12-165 CV</p>	<p>A100-SLRA12-195 CV</p>	<p>A100-SLRA12-225 CV</p>
<p>A100-SLRA12-255 CV</p>	<p>A100-SLRA12-285 CV</p>	<p>A100-SLFA12-165 CV</p>	<p>A100-SLFA12-195 CV</p>

Feature
Shrink-fit Heater

MONO 3°
MONO CURVE
MONO Series

2PIECE type
UNO

HYPER version

STRAIGHT arbor

OTHERS

PERIPHERALS

Technical Information

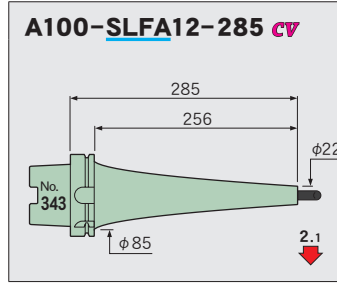
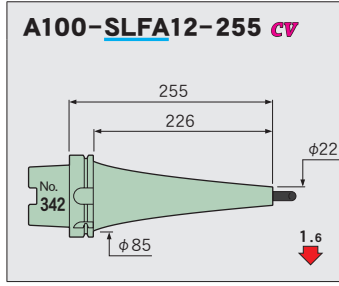
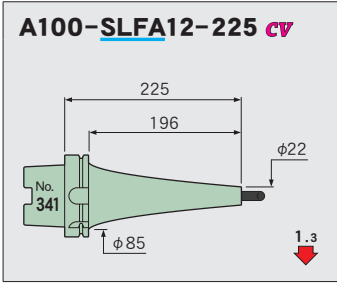

φ 1/2

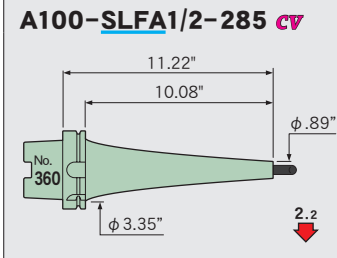
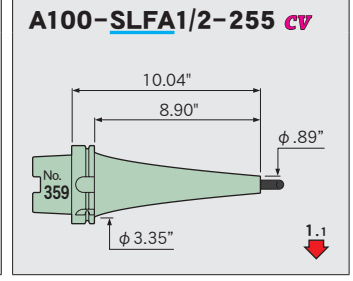
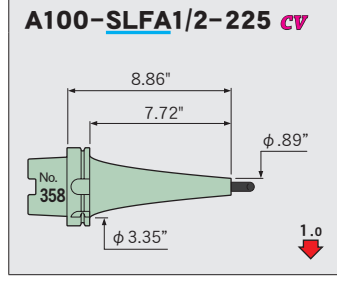
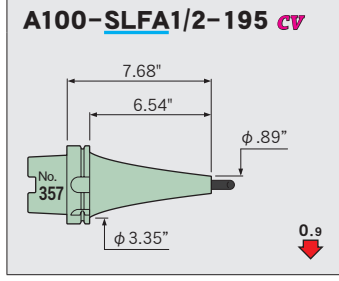
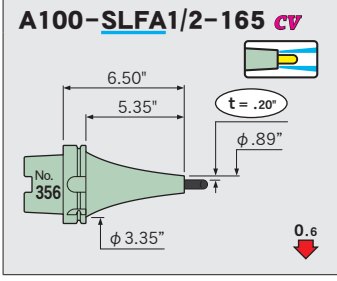
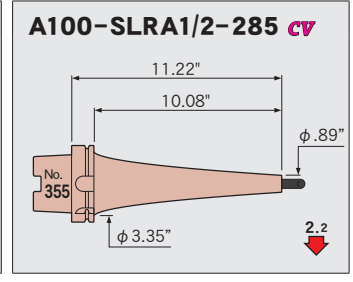
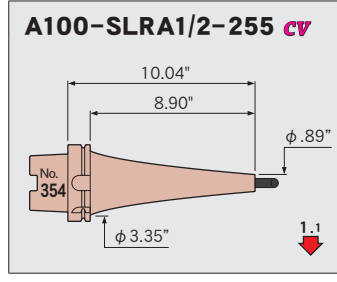
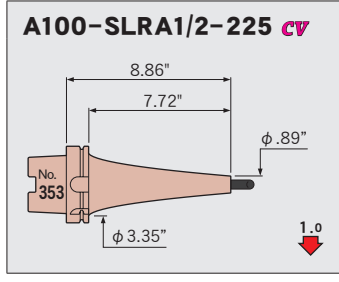
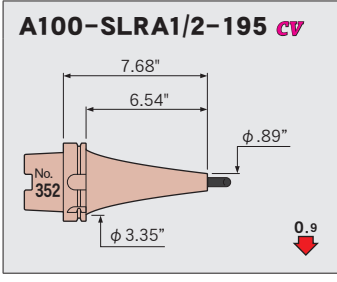
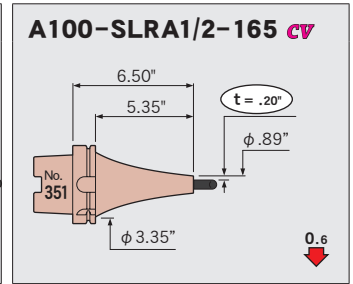
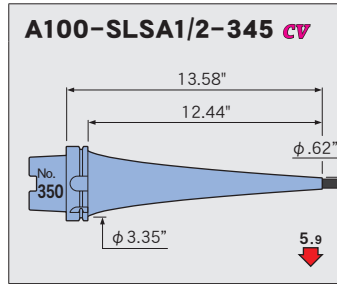
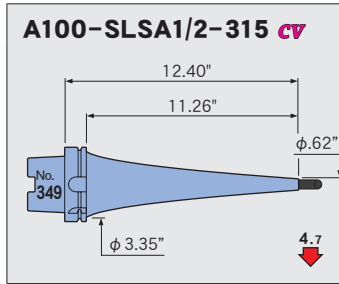
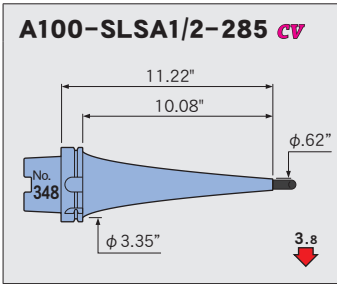
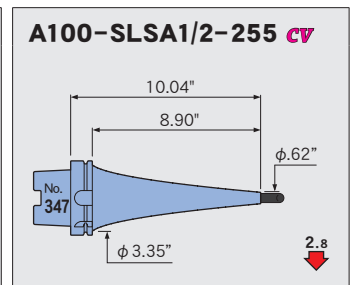
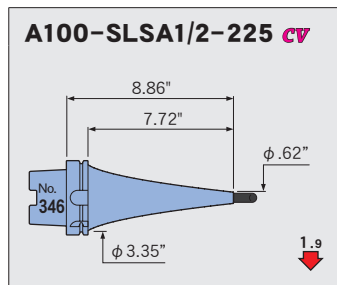
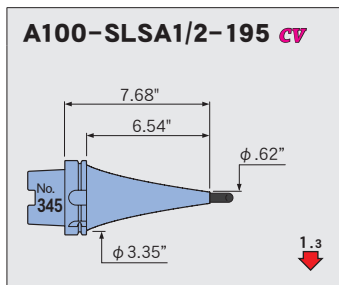
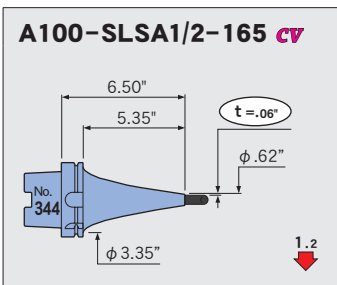

φ16

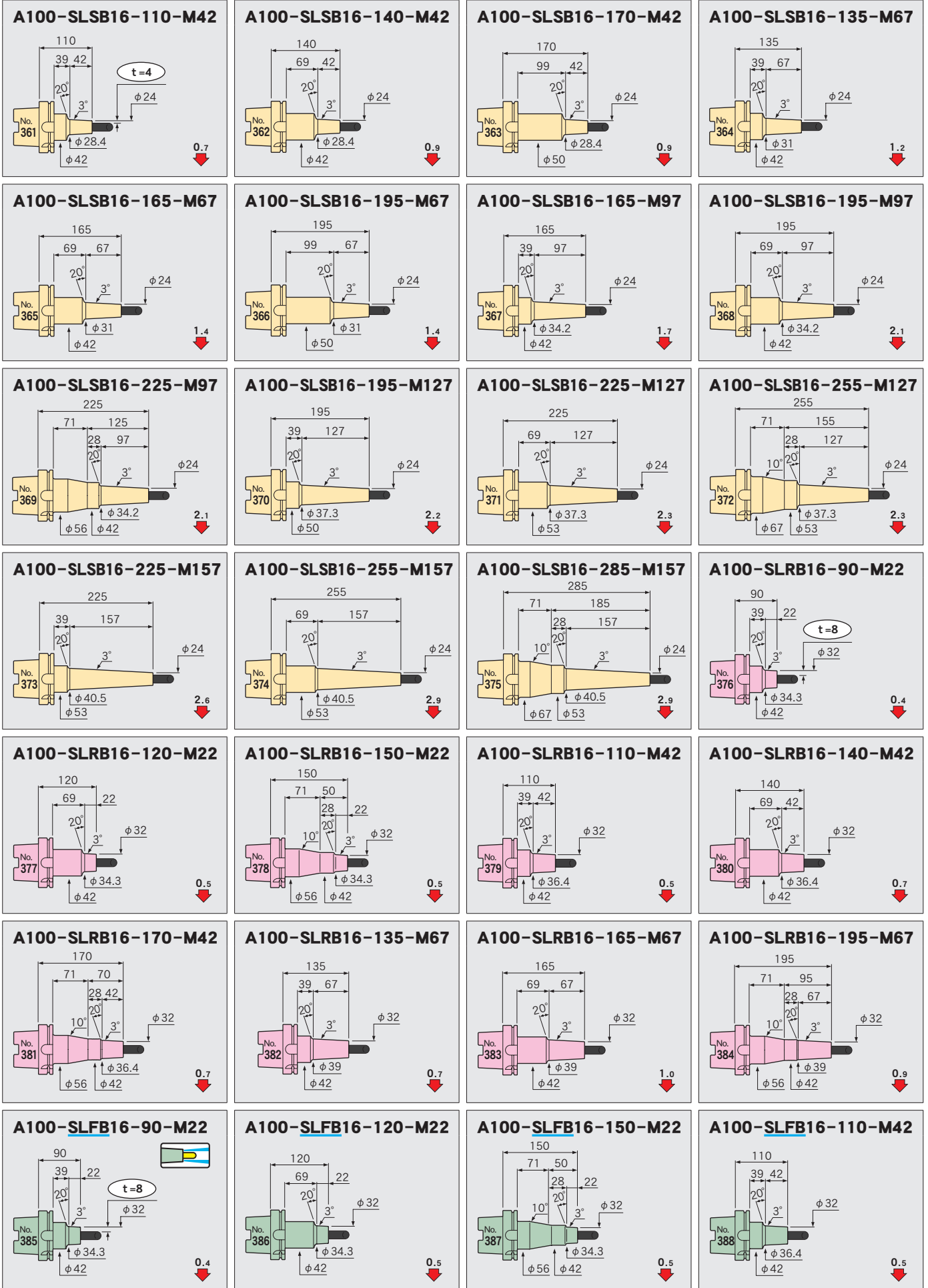

Feature
Shrink-fit Heater

MONO 3°
MONO CURVE

MONO Series

2PIECE type

UNO

HYPER
version

STRAIGHT
arbor

OTHERS

PERIPHERALS

Technical
Information

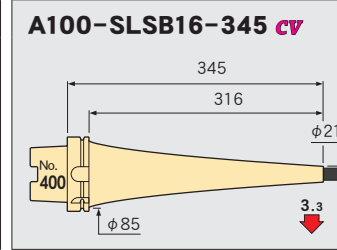
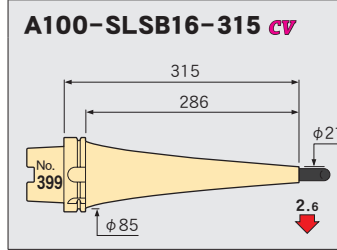
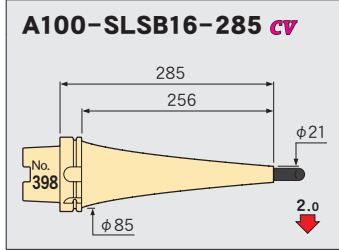
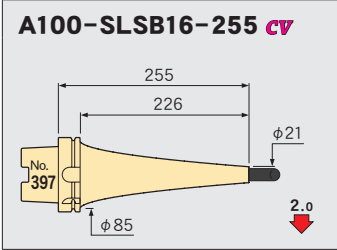
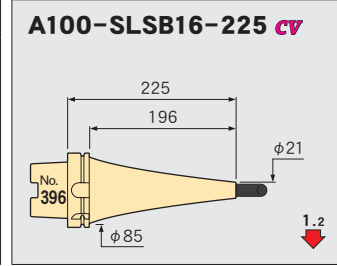
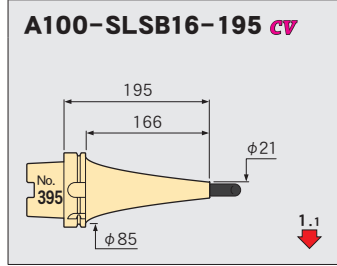
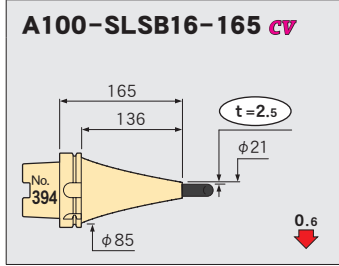
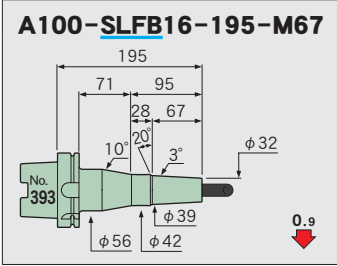
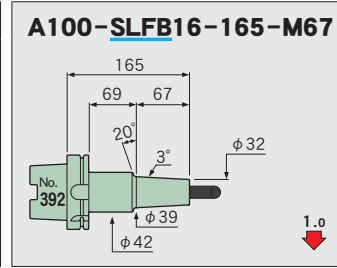
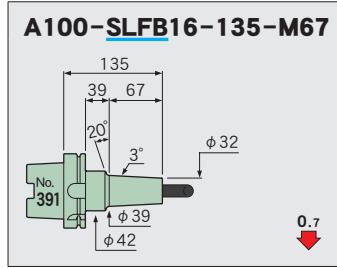
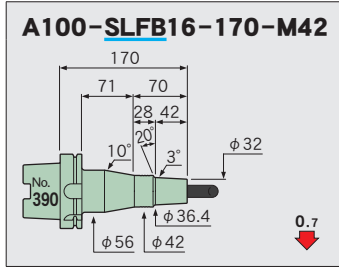
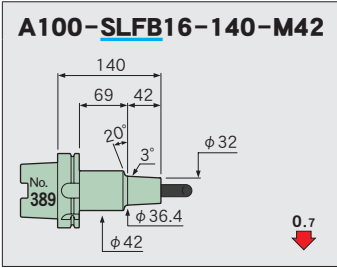

φ 5/8

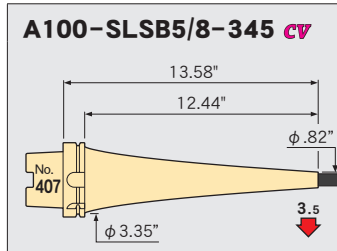
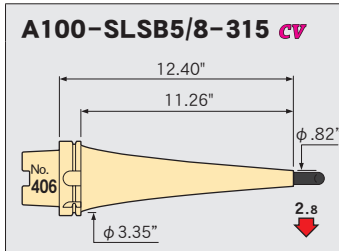
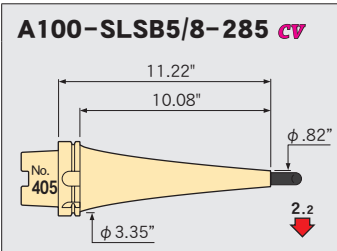
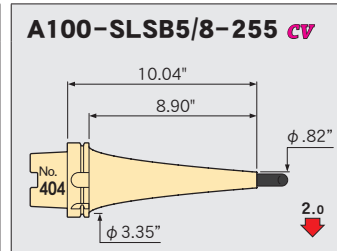
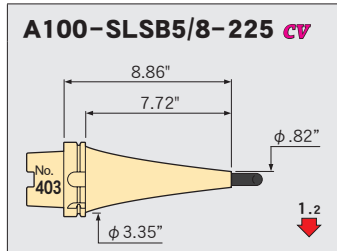
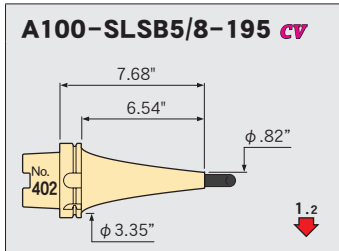
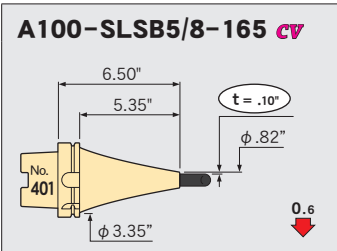

φ20

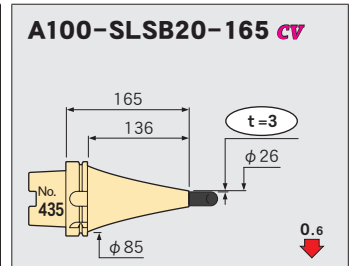
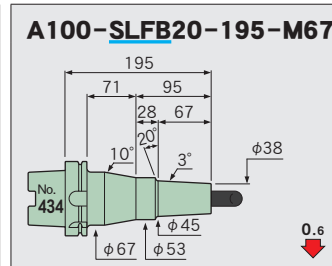
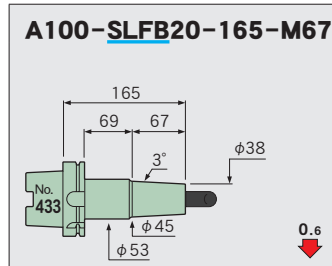
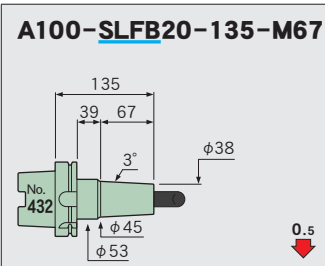
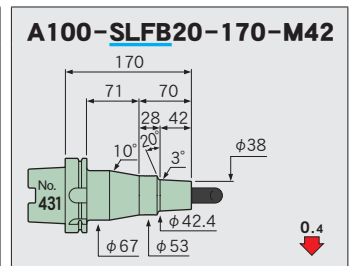
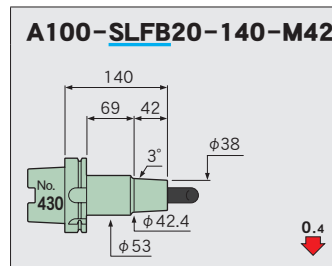
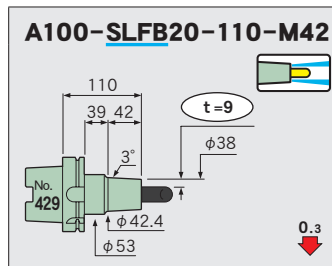
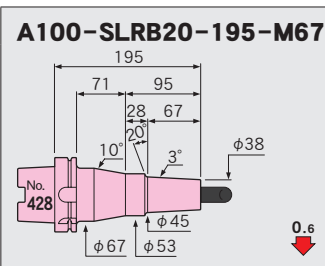
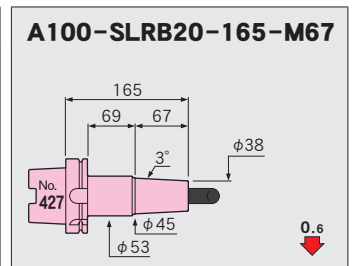
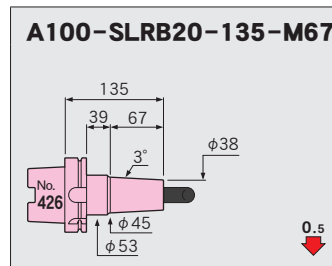
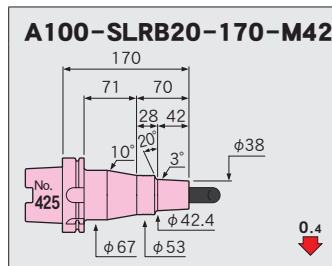
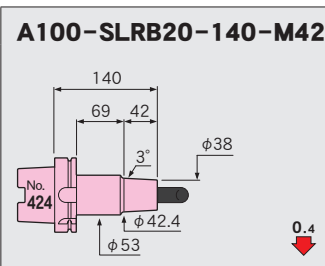
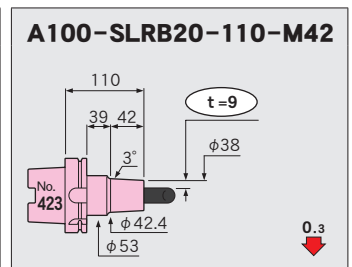
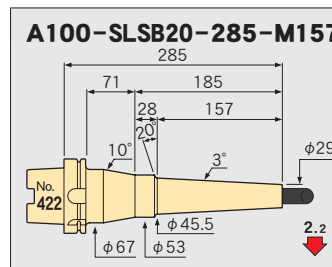
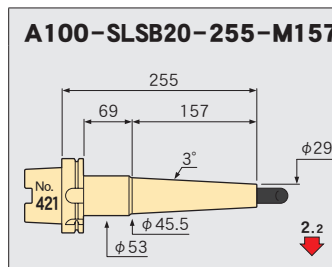
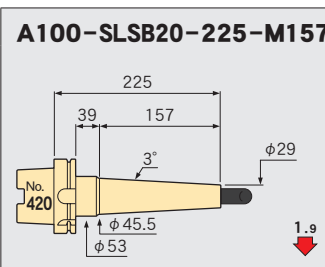
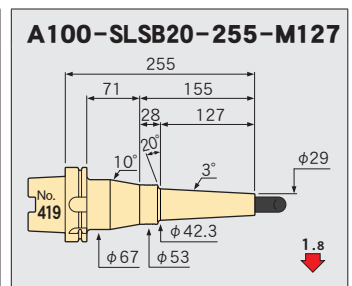
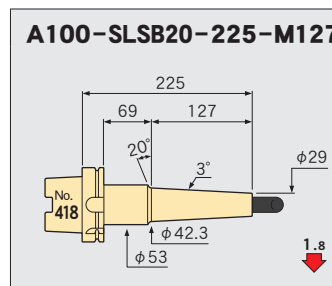
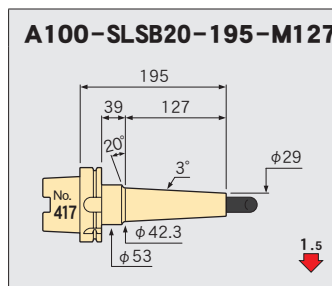
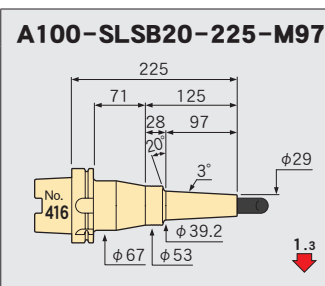
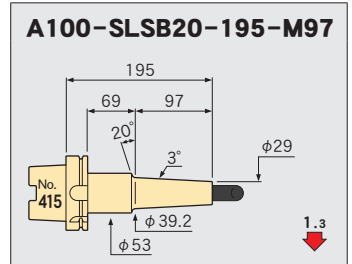
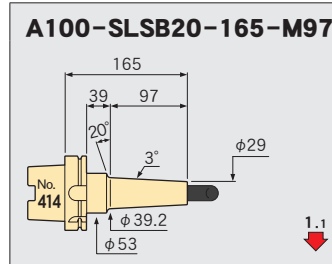
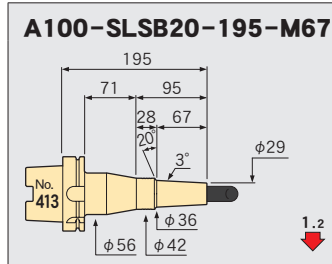
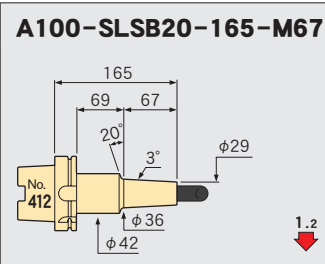
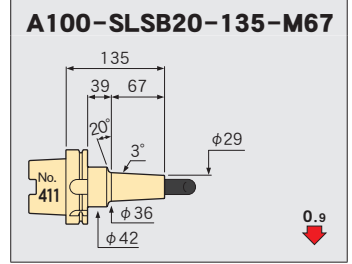
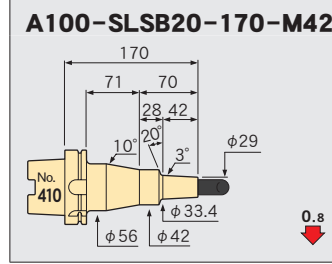
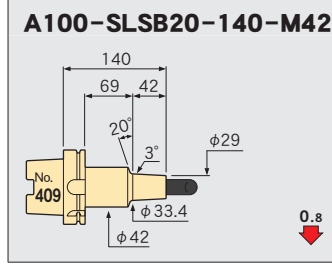
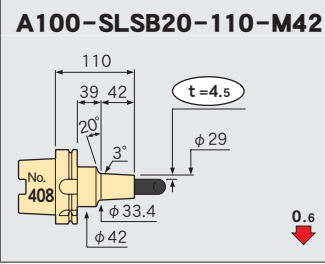

Feature

Shrink-fit Heater

MONO 3°
MONO CURVE

MONO Series

2PIECE type

UNO

HYPER
version

STRAIGHT
arbor

OTHERS

PERIPHERALS

Technical
Information

A100 S=1:10

Feature
Shrink-fit Heater

MONO 3°
MONO CURVE
MONO Series

2PIECE type

UNO

HYPER version

STRAIGHT arbor

OTHERS

PERIPHERALS

Technical Information

A100-SLSB20-195 CV

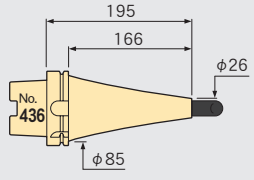

A100-SLSB20-225 CV

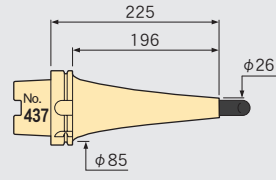

A100-SLSB20-255 CV

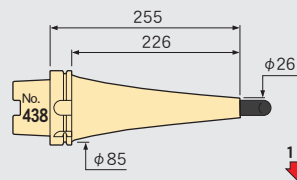

A100-SLSB20-285 CV

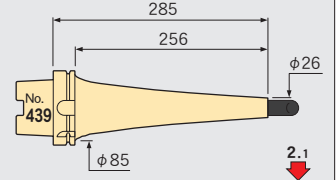

A100-SLSB20-315 CV

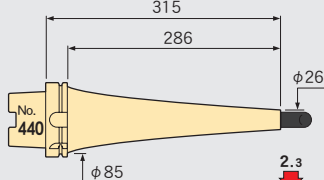

A100-SLSB20-345 CV

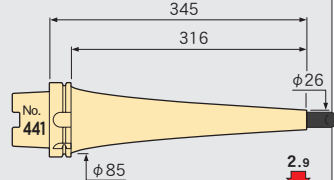

φ 3/4

A100-SLSB3/4-165 CV

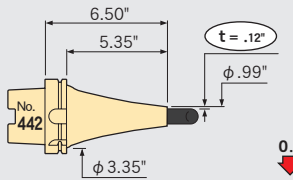

A100-SLSB3/4-195 CV

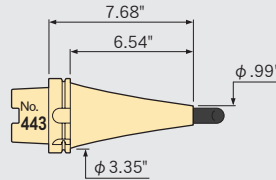

A100-SLSB3/4-225 CV

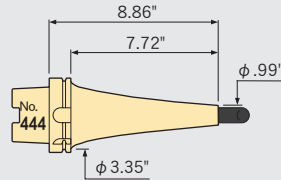

A100-SLSB3/4-255 CV

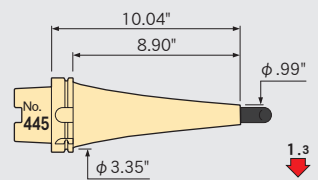

A100-SLSB3/4-285 CV

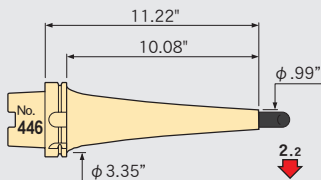

A100-SLSB3/4-315 CV

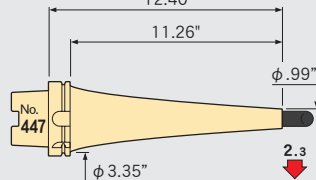

A100-SLSB3/4-345 CV

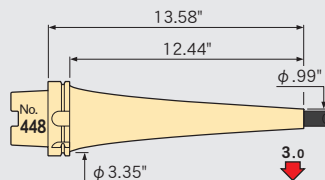

φ 25

A100-SLRB25-110-M42

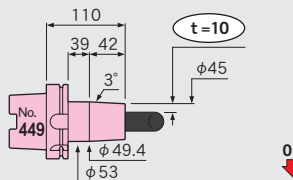

A100-SLRB25-140-M42

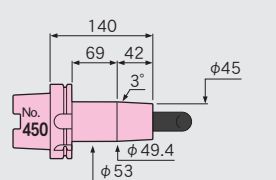

A100-SLRB25-170-M42

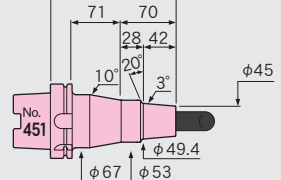

A100-SLFB25-110-M42

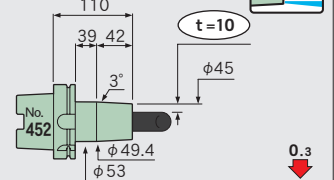

A100-SLFB25-140-M42

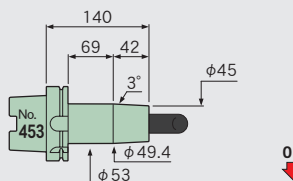

A100-SLFB25-170-M42

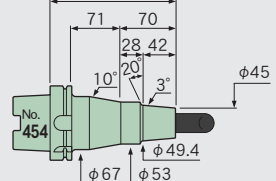

φ32

A100-SLRB32-110-M42

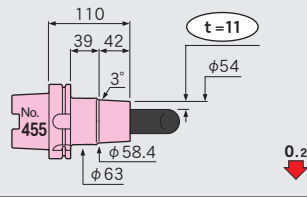

A100-SLRB32-140-M42

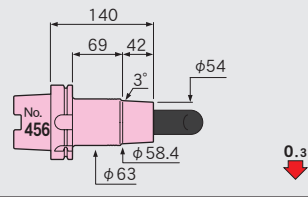

A100-SLRB32-170-M42

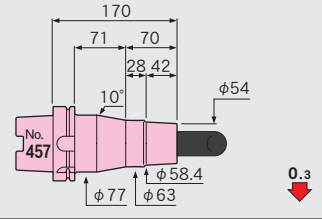

■ φ70 Nozzle (HRB-03S)

Required for shrinking the SLRB32.

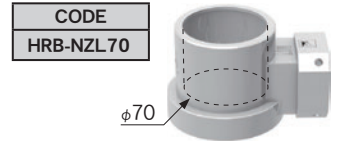

HEAT ROBO Baby 3000S

Feature

Shrink-fit Heater

MONO 3°
MONO CURVE

MONO Series

2PIECE type

UNO

HYPER
version

STRAIGHT
arbor

OTHERS

PERIPHERALS

Technical
Information

E25

MONO 3°

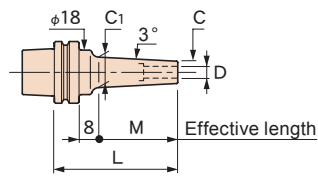
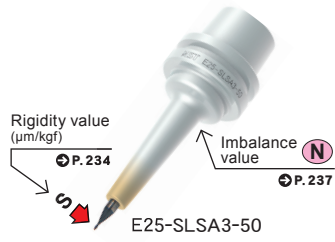

Caution

- The coolant duct is not installed in a holder. Consult us if you need it.
- Setting cutters - Be sure to insert the tool beyond the safety mark.

CODE	φD	φC	t	L	M	L ₁	φC ₁	H	h	Kg	N	S	Scale model
E25-SLSA3-35	3	6	1.5	35	17	8	7.8	9	29	0.06	0.37	3.6	1
-50				50	32		9.4		44		0.39	7	2
-SLRA3-35				7.5	2.25		35		17		9.3	29	0.37
E25-SLSA3.175-35	3.175	6.175	1.5	35	17	8	8	9	29	0.06	0.37	3.5	4
-50				50	32		9.6		44		0.39	6.6	5
E25-SLSA4-35	4	7	1.5	35	17	8	8.8	12	29	0.06	0.38	2.8	6
-50				50	32		10.4		44		0.4	5.3	7
-SLRA4-35				10	3		35		17		11.8	29	0.38
E25-SLSA5-35	5	8	1.5	35	17	8	9.8	15	26	0.06	0.38	2.2	9
E25-SLSA6-35	6	9	1.5	35	17	8	10.8	18	26	0.05	0.38	1.8	10
-50				50	32		12.4		39		0.07	0.43	3.6
-SLRA6-35				12	3		35		17	13.8	26	0.39	1.1

A short carbide end-mill for the shrink-fit holder

The shrink-fit holder doesn't need standard length cutting tools, because it has shorter insertion length.

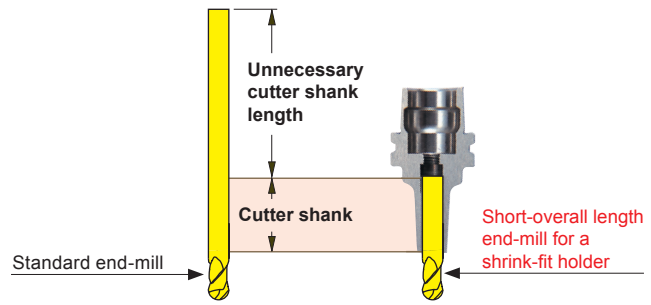
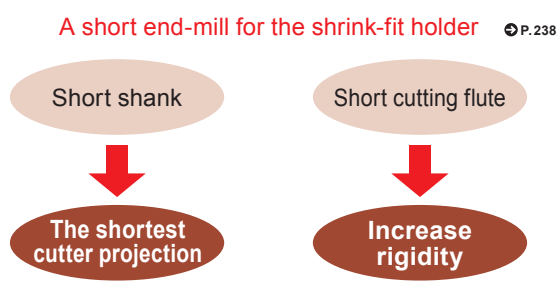

Centering bar
To identify workpiece datum position

CODE
ST6-CEB102

Measuring instrument tool holder
Use when centering a workpiece. The spring collet (C10-6-P) and the centering bar (ST6-CEB102) are required and sold separately. Fasten nuts by hand.

CODE
E25-CEH10-37

Caution
• Not usable for machining.

Cleaning tool for a spindle taper hole, STAR DUST

CODE
CLT-E25-G1

P.226

Holder Stand
P.16

Be aware of max. insertion length (h)!

If you insert cutter beyond the max. insertion length (h), the machine spindle might not be able to clamp the holder properly and thus damage the spindle. Please use our exclusive adapter to recognize the max. insertion length when you shrink-fit.

Sodick UH430L / UH650L
TT1-400A / OPM series

MITSUI SEIKI VL30 / VL50

ROKU-ROKU P12-C genesis / Amdroid II
MEGA series / HC-435

YASDA YMC series

φ3

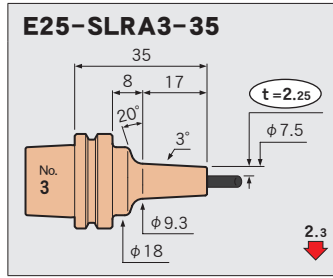
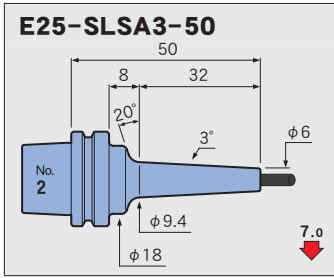
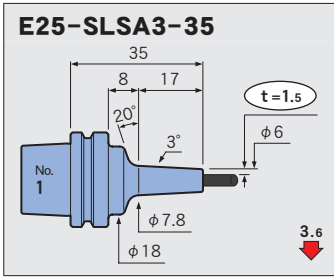

φ3.175

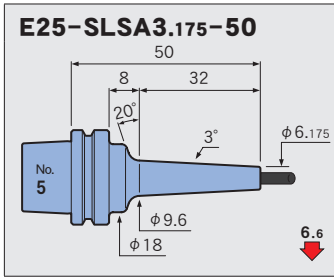
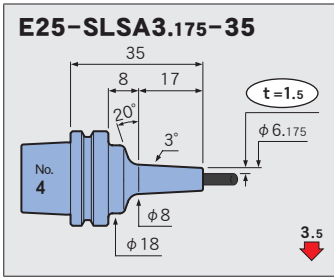

φ4

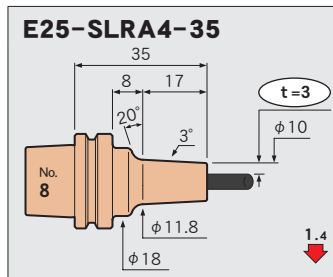
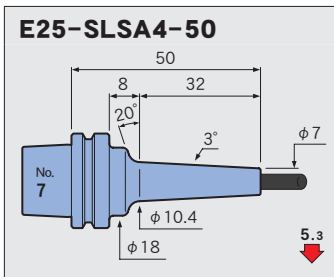
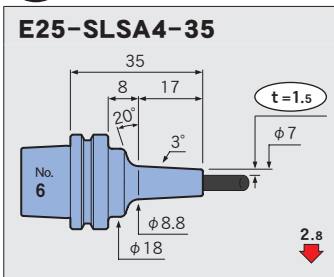

φ5

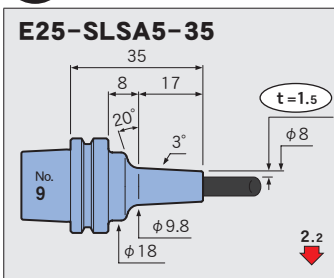

φ6

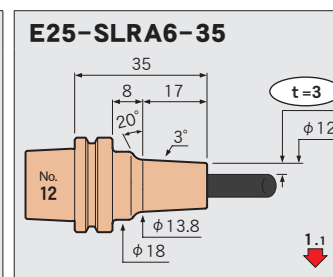
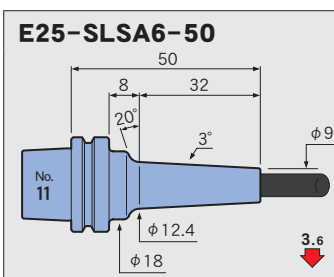
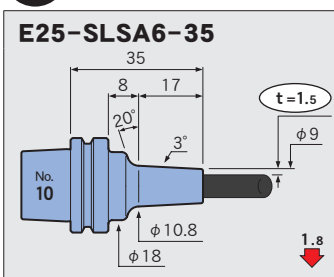

Feature

Shrink-fit Heater

MONO 3°
MONO CURVE

MONO Series

2PIECE type

UNO

HYPER
version

STRAIGHT
arbor

OTHERS

PERIPHERALS

Technical
information



MONO 3°

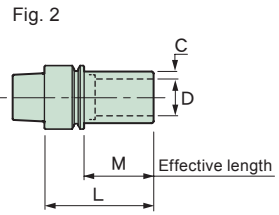
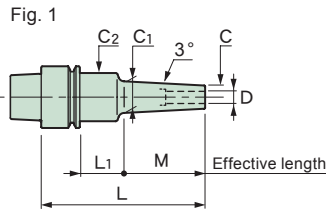
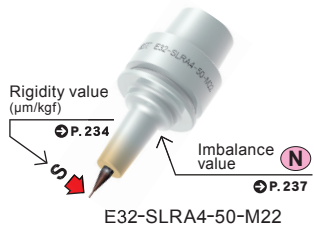

MONO CURVE CV

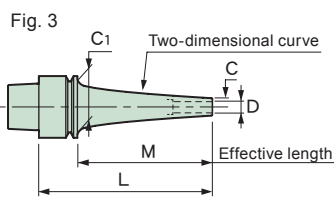

Caution

- The coolant duct is not installed in a holder. Consult us if you need it.
- Setting cutters... Be sure to insert the tool beyond the safety mark.

Safety mark, Thickness t, Clamping length H, Max. insertion length h

CV : Curve Thickness

CODE	Fig.	φD	φC	t	L	M	L ₁	φC ₁	φC ₂	H	h	Kg lbs	(N)	S	Scale model
E32-SLSA3-50-M22	1	3	6	1.5	50	22	8	8.3	20	9	42	0.1	0.4	4.7	1
70					42	10.4		62			0.2				9.5
-85-M42					85	23	25	77	0.8		9.4	3			
-SLRA3-50-M22	1	3	7.5	2.25	50	22	8	9.8	20	9	42	0.1	0.4	2.8	4
70					42	11.9		62			0.2				5.3
-85-M42					85	23	25	77	0.8		5.5	6			
E32-SLSA3.175-50-M22	1	3.175	6.175	1.5	50	22	8	8.5	20	9	42	0.1	0.4	4.4	7
E32-SLSA4-50-M22	1	4	7	1.5	50	22	8	9.3	20	12	42	0.1	0.4	3.6	8
70					42	11.4		62			0.2				7.3
-85-M42					85	23	25	77	0.8		7.4	10			
-SLRA4-50-M22	1	4	10	3	50	22	8	12.3	20	12	42	0.2	0.4	1.7	11
70					42	14.4		62			0.5				3.1
-85-M42					85	23	25	77	0.9		3.2	13			
-SLSA4-60 CV	3	4	7	1.5	60	40	—	26	—	12	43	0.2	0.6	2.4	14
-90 CV					90	70					73				0.8
E32-SLSA3/16-60 CV	3	3/16	.31	.06	2.37	1.58	—	1.02	—	.59	1.69	0.4	0.6	2.4	16
-90 CV					3.55	2.76					2.87				0.5
E32-SLSA6-70-M42	1	6	9	1.5	70	42	8	13.4	20	18	62	0.2	0.5	4.8	18
-SLRA6-50-M22	1	6	12	3	50	22	8	14.3	26	18	39	0.2	0.5	1.2	19
70					42	16.4		62			2.4				20
-85-M42					85	23	25	77	0.9		2.5	21			
-SLSA6-60 CV	3	6	9	1.5	60	40	—	26	—	18	43	0.2	0.7	1.9	22
-90 CV					90	70					73				0.9
E32-SLSA1/4-60 CV	3	1/4	.37	.06	2.37	1.58	—	1.02	—	.71	1.69	0.4	0.7	1.9	24
-90 CV					3.55	2.76					2.87				0.5
E32-SLRA8-50-M22	1	8	14	3	50	22	8	16.3	26	24	39	0.2	0.5	1	26
-85-M42					85	42		23			18.4				25
-SLSA8-60 CV	3	8	11	1.5	60	40	—	26	—	24	38	0.2	0.7	1.6	28
-90 CV					90	70					73				1
E32-SLSA5/16-60 CV	3	5/16	.43	.06	2.37	1.58	—	1.02	—	.94	1.89	0.4	0.7	1.6	30
-90 CV					3.55	2.76					2.36				0.5
E32-SLRA10-55-M22	1	10	16	3	55	22	13	18.3	26	25	44	0.2	0.6	0.9	32
-SLSA10-60 CV	3	10	13	1.5	60	40	—	26	—	30	48	0.2	0.8	1.4	33
-90 CV					90	70					60				1.1

CODE	Fig.	φD	φC	t	L	M	L ₁	φC ₁	φC ₂	H	h	Kg lbs	N	S	Scale model
E32-SLSA3/8-60 CV	3	3/8	.49	.06	2.37	1.58	—	1.02	—	1.18	1.89	0.4	0.8	1.4	35
-90 CV					3.55	2.76					2.36	0.5	1.1	3.5	36
E32-SLRA12-55-M22	1	12	20	4	55	22	13	22.3	26	30	44	0.2	0.7	0.7	37
E32-SLRA16-55-M35	2	16	26	5	55	35	—	—	—	32	44	0.2	0.6	0.7	38

■ Cleaning tool for a spindle taper hole, STAR DUST

CODE
CLT-E32-G4

➔ P.226



■ Holder stand

➔ P.16



⚠ Be aware of max. insertion length (h)!

If you insert cutter beyond the max. insertion length (h), the machine spindle might not be able to clamp the holder properly and thus damage the spindle. Please use our exclusive adapter to recognize the max. insertion length when you shrink-fit.

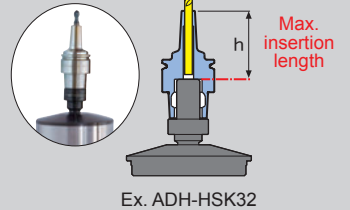

- | | |
|---------------------|---------------------------|
| DMG MORI | HSC 20 linear |
| HORKOS | NJ35-5AX |
| MAKINO | V22 / V33 / IQ300 / IQ500 |
| MITSUI SEIKI | VL30 / VL50 |
| Nidec | μV1 |
| Sodick | UH430L / UH650L |
| SUGINO | Xion α-5AX |
| YASDA | YMC650 / YMC430 ver III |



S=1:3

φ3

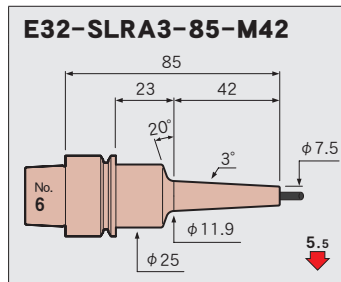
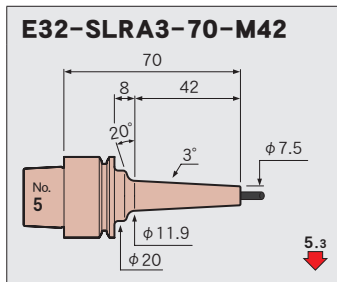
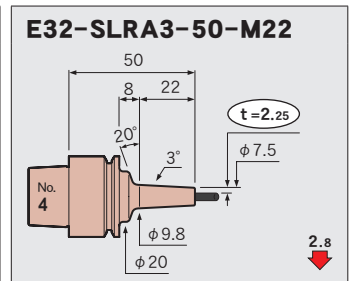
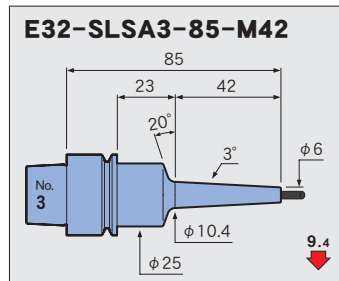
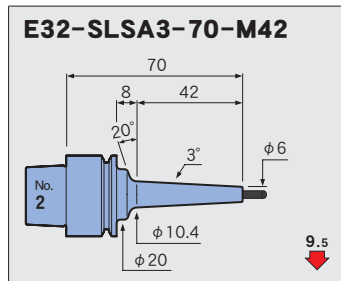
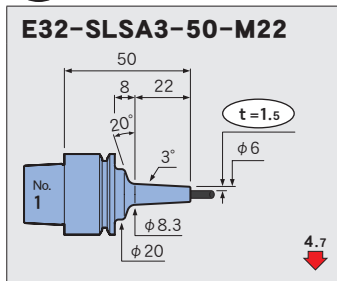

φ3.175

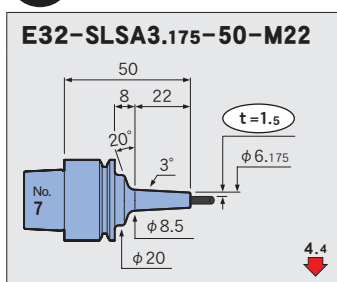

φ 4

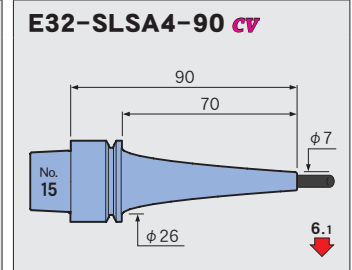
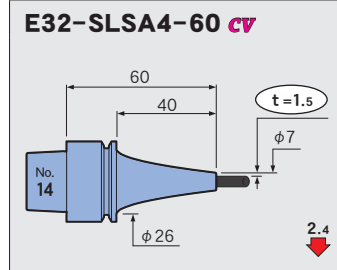
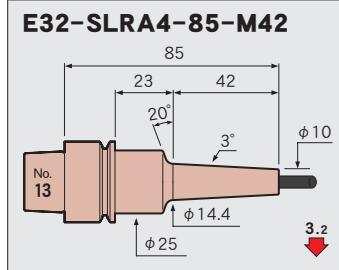
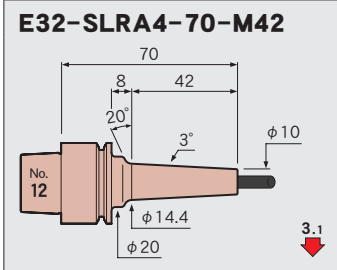
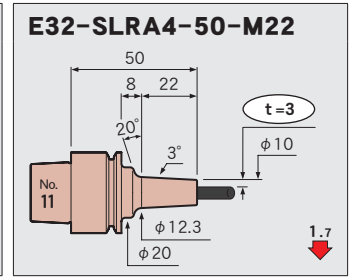
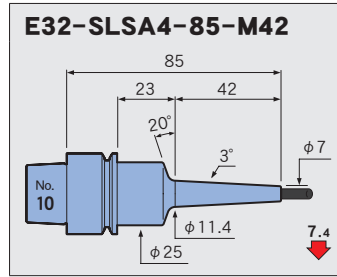
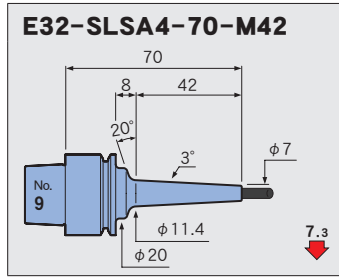
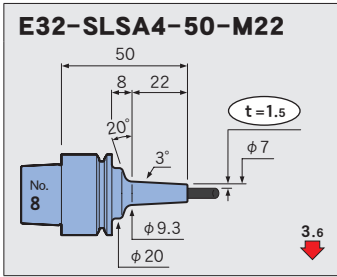

φ 3/16

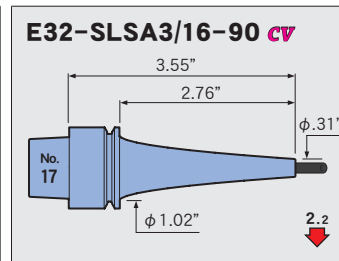
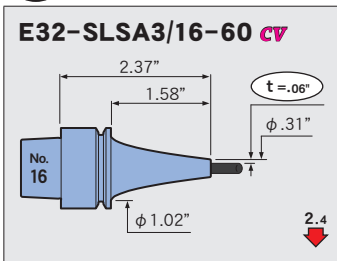

φ 6

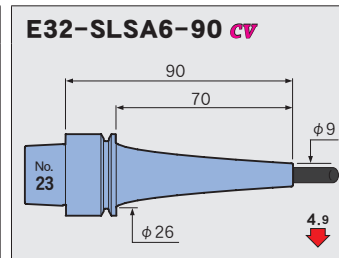
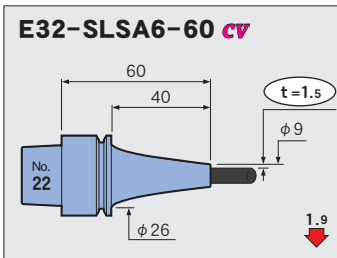
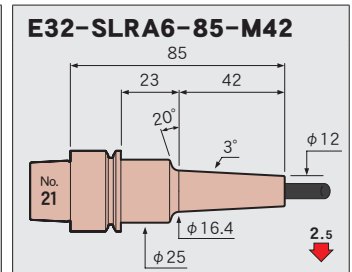
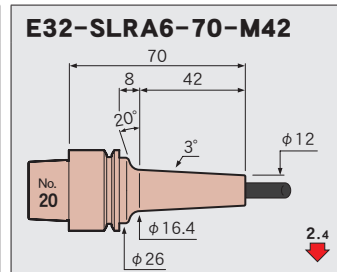
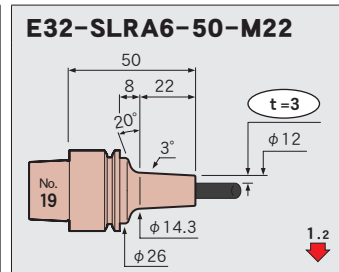
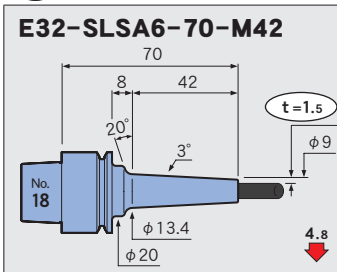

φ 1/4

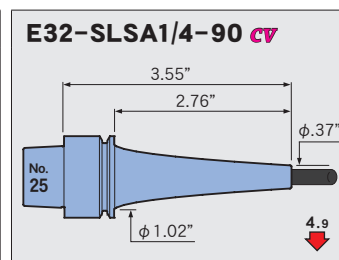
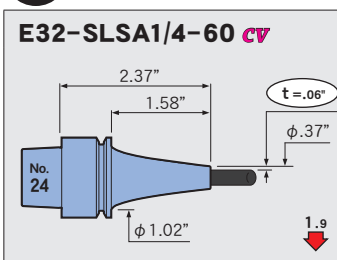

Feature
Shrink-fit Heater
MONO 3° MONO CURVE
MONO Series
2PIECE type
UNO
HYPER version
STRAIGHT anbor
OTHERS
PERIPHERALS
Technical Information

φ 8

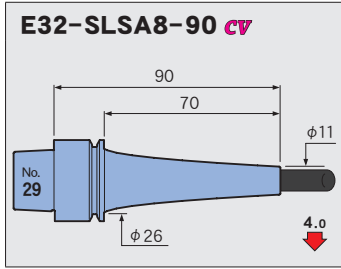
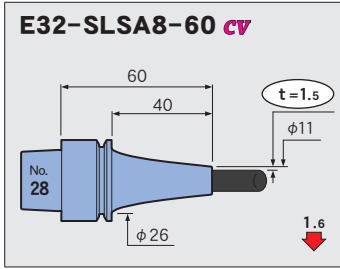
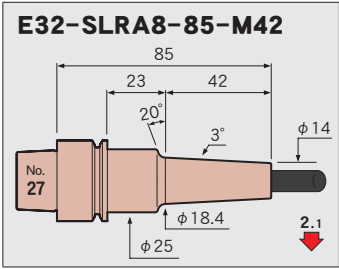
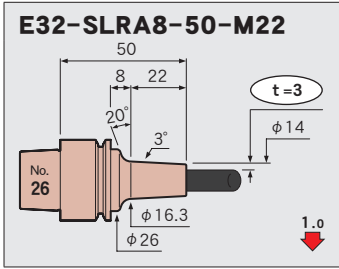

φ 5/16

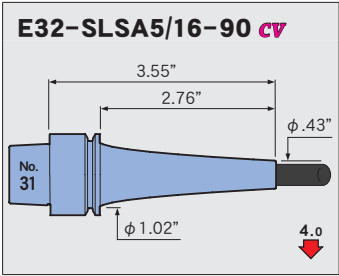
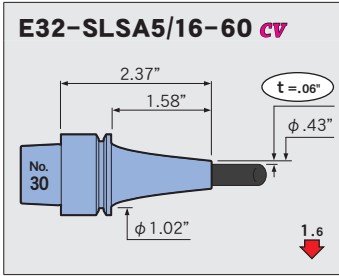

φ 10

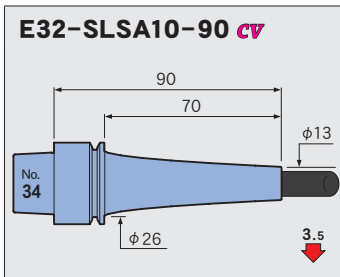
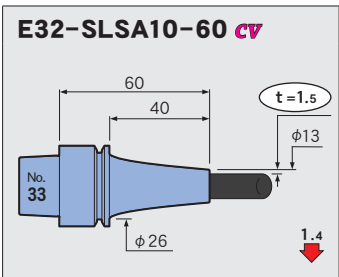
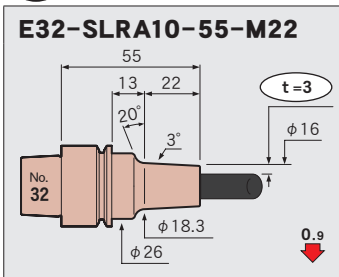

φ 3/8

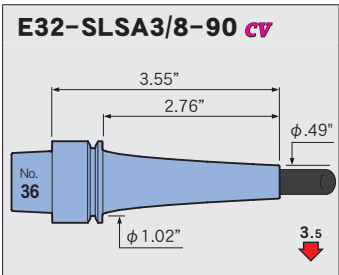
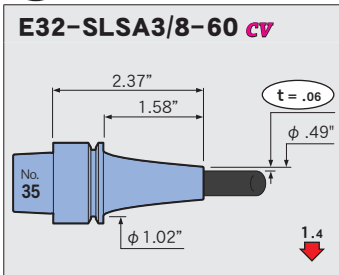

φ 12

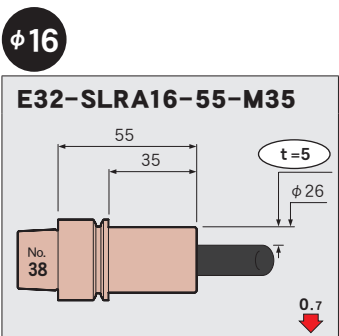
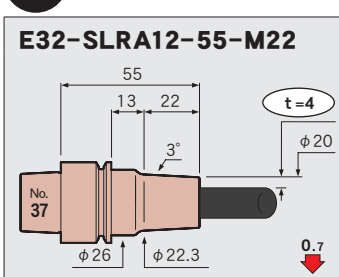

Feature
Shrink-fit Heater
MONO 3° MONO CURVE
MONO Series
2PIECE type
UNO
HYPER version
STRAIGHT arbor
OTHERS
PERIPHERALS
Technical Information

E40

MONO 3°

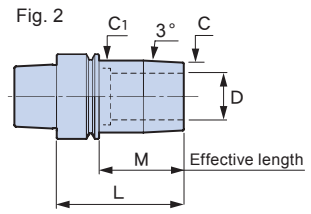
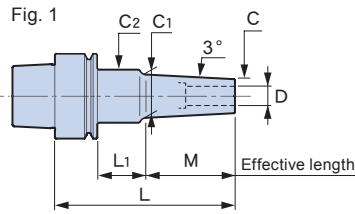

MONO CURVE

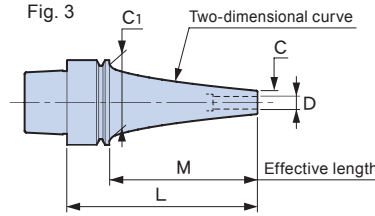

Caution

- The coolant duct is not installed in a holder. Consult us if you need it.
- Setting cutters... Be sure to insert the tool beyond the safety mark.

cv : Curve

Thickness

CODE	Fig.	φD	φC	t	L	M	L1	φC1	φC2	H	h	Kg lbs	N	S	Scale model		
E40-SLSA3- 50-M22	1	3	6	1.5	50	22	8	8.3	20	9	42	0.2	0.7	4.6	1		
- 70-M42					70	42		10.4			62			9.4	2		
- 85-M42					85	23	25	69	0.3		1.1	9.3	3				
-110-M67					110			67	13		94	2.2	15	4			
-SLRA3- 50-M22	1	3	7.5	2.25	50	22	8	9.8	20	9	42	0.2	0.7	2.8	5		
- 70-M42					70	42		11.9			62			5.3	6		
- 85-M42					85	23	25	69	0.3		1.1	5.4	7				
-110-M67					110			67	14.5		94	9	8				
E40-SLSA3.175-50-M22	1	3.175	6.175	1.5	50	22	8	8.5	20	9	42	0.2	0.7	4.4	9		
E40-SLSA4- 50-M22	1	4	7	1.5	50	22	8	9.3	20	12	42	0.2	0.7	3.6	10		
- 70-M42					70	42		11.4			62			7.2	11		
- 85-M42					85	23	25	74	0.3		1.1	7.3	12				
-110-M67					110			67	14		99	1.2	11.9	13			
-SLRA4- 50-M22	1	4	10	3	50	22	8	12.3	20	12	42	0.2	0.7	1.6	14		
- 70-M42					70	42		14.4			62			0.3	3	15	
- 85-M42					85	23	25	69	1.1		3.1	16					
-110-M67					110			67				17	94	1.2	5.2	17	
-SLSA4- 90 cv	3	4	7	1.5	90	70	—	34	—	12	74	0.3	1.5	2.9	18		
-120 cv					120	100					104			0.4	1.8	6.5	19
-150 cv					150	130					134			0.5	2.4	8.6	20
-SLRA4- 90 cv	3	4	10	3	90	70	—	34	—	12	74	0.4	1.6	2	21		
-120 cv					120	100					104			1.9	4.2	22	
E40-SLSA3/16- 90 cv	3	3/16	.31	.06	3.55	2.76	—	1.34	—	0.59	2.91	0.8	1.7	2.9	23		
-120 cv					4.73	3.94					4.09			1.9	6.5	24	
-150 cv					5.91	5.12					5.28			1.1	2.6	8.6	25
-SLRA3/16- 90 cv	3	3/16	.42	.12	3.55	2.76	—	1.34	—	0.59	2.91	0.8	1.7	2	26		
-120 cv					4.73	3.94					4.09			0.9	2	4.2	27
E40-SLSA6- 50-M22	1	6	9	1.5	50	22	8	11.3	20	18	39	0.2	0.7	2.2	28		
- 70-M42					70	42		13.4			54			4.7	29		
- 85-M42					85	23	25	69	0.3		1.1	4.9	30				
-110-M67					110			67	16		94	1.2	8	31			
-SLRA6- 50-M22	1	6	12	3	50	22	8	14.3	26	18	39	0.2	0.7	1.2	32		
- 70-M42					70	42		16.4			54			0.3	0.8	2.3	33
- 85-M42					85	23	25	69	1.2		2.5	34					
-110-M67					110			67				19	94	0.4	4.1	35	

CODE	Fig.	φD	φC	t	L	M	L ₁	φC ₁	φC ₂	H	h				Scale model			
E40-SLSA6- 90 CV	3	6	9	1.5	90	70	—	34	—	18	74	0.3	1.6	2.5	36			
-120 CV					120	100					104	0.4	1.9	5.6	37			
-150 CV					150	130					134	0.5	2.5	7.7	38			
-SLRA6- 90 CV	3	6	13	3.5	90	70	—	34	—	18	74	0.4	1.7	1.7	39			
-120 CV					120	100					104	0.5	2.4	2.6	40			
E40-SLSA1/4- 90 CV	3	1/4	.37	.06	3.55	2.76	—	1.34	—	0.71	2.91	0.8	1.7	2.5	41			
-120 CV					4.73	3.94					4.09	0.9	2	5.6	42			
-150 CV					5.91	5.12					5.28	1.1	2.6	7.7	43			
-SLRA1/4- 90 CV	3	1/4	.53	.14	3.55	2.76	—	1.34	—	0.71	2.91	0.8	1.8	1.7	44			
-120 CV					4.73	3.94					4.09	1.0	2.5	2.6	45			
E40-SLSA 8- 60-M22	1	8	11	1.5	60	22	18	13.3	26	24	49	0.3	1	1.5	46			
- 80-M42					80	42		15.4			64			3.3	47			
-100-M42					100	38		25			84			1.5	3.8	48		
-SLRA 8- 50-M22	1	8	14	3	50	22	8	16.3	26	20	39	0.2	0.7	0.9	49			
- 85-M42					85	42	23	18.4			25		24	69	0.3	1.2	2.1	50
-100-M42					100	38	84	0.4			1.5		2.4	51				
-SLSA 8- 90 CV	3	8	11	1.5	90	70	—	34	—	24	74	0.3	1.7	2.2	52			
-120 CV					120	100					104		0.4	2	3.4	53		
-150 CV					150	130					134		0.5	3	5.1	54		
-SLRA 8- 90 CV	3	8	16	4	90	70	—	34	—	24	74	0.4	1.8	1.6	55			
-120 CV					120	100					104		0.5	2.5	2.4	56		
E40-SLSA5/16- 90 CV	3	5/16	.43	.06	3.55	2.76	—	1.34	—	0.94	2.91	0.8	1.7	2.2	57			
-120 CV					4.73	3.94					4.09		0.9	2.1	3.4	58		
-150 CV					5.91	5.12					5.28		1.1	2.8	5.1	59		
-SLRA5/16- 90 CV	3	5/16	.63	.16	3.55	2.76	—	1.34	—	0.94	2.91	0.9	2.2	1.6	60			
-120 CV					4.73	3.94					4.09		1.1	2.6	2.4	61		
E40-SLSA10- 60-M22	1	10	13	1.5	60	22	18	15.3	26	30	49	0.3	1	1.2	62			
- 80-M42					80	42		17.4			64		1.1	2.4	63			
-100-M42					100	38		25			89		1.5	3.1	64			
-SLRA10- 55-M22	1	10	16	3	55	22	13	18.3	26	25	44	0.3	0.9	0.8	65			
- 85-M42					85	42	23	20.4			25		30	64	1.2	1.7	66	
-100-M42					100	38	0.4	1.6			2.2		67					
-SLSA10- 90 CV	3	10	13	1.5	90	70	—	34	—	30	74	0.3	1.7	2	68			
-120 CV					120	100					104		0.4	2.4	3.2	69		
-150 CV					150	130					134		0.5	3.1	5	70		
-SLRA10- 90 CV	3	10	19	4.5	90	70	—	34	—	30	74	0.4	2.1	1.1	71			
-120 CV					120	100					104		0.5	2.9	2	72		
E40-SLSA3/8- 90 CV	3	3/8	.49	.06	3.55	2.76	—	1.34	—	1.18	2.91	0.8	1.8	2	73			
-120 CV					4.73	3.94					4.09		1.0	2.5	3.2	74		
-150 CV					5.91	5.12					5.28		1.2	3.2	5	75		
-SLRA3/8- 90 CV	3	3/8	.73	.185	3.55	2.76	—	1.34	—	1.18	2.91	0.9	2.3	1.1	76			
-120 CV					4.73	3.94					4.09		1.2	3	2	77		
E40-SLRA12- 55-M22	1	12	20	4	55	22	13	22.3	26	25	44	0.3	1	0.6	78			
- 85-M42					85	42	23	24.4			32		30	74	0.4	1.6	1.1	79
E40-SLRA16- 55-M22	1	16	26	5	55	22	13	28.3	34	32	44	0.3	1.2	0.4	80			
E40-SLRA20- 60-M40	2	20	32	6	60	40	—	34	—	38	49	0.4	1.6	0.4	81			

■ Cleaning tool for a spindle taper hole, STAR DUST

CODE
CLT-E40-G2

Ⓢ P. 226



DMG MORI	HSC 30 linear
MITSUI SEIKI	VL30 / VL50
MATSUURA	LS-160 / LX-160 / LF-160 / LV-500
ROKU-ROKU	VISION/CEGA HC series
YASDA	YMC650
YAMAZAKI MAZAK	UD-400 5X



φ3

E40-SLSA3-50-M22

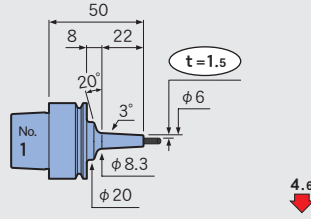

E40-SLSA3-70-M42

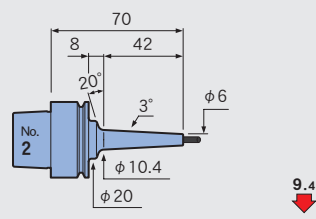

E40-SLSA3-85-M42

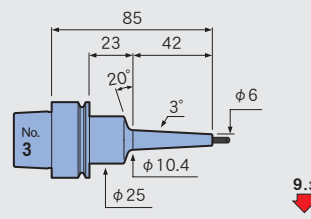

E40-SLSA3-110-M67

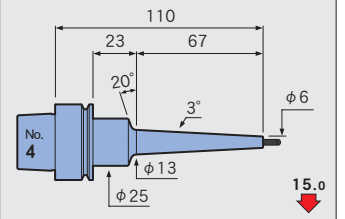

E40-SLRA3-50-M22

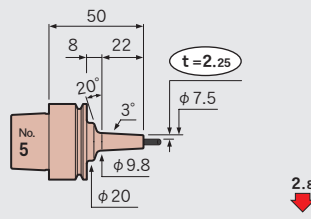

E40-SLRA3-70-M42

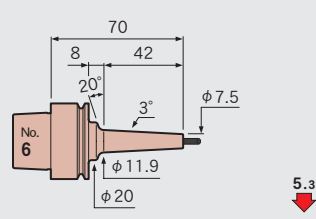

E40-SLRA3-85-M42

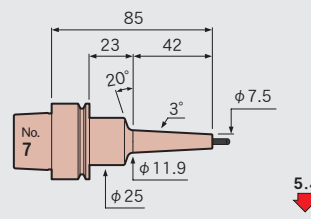

E40-SLRA3-110-M67

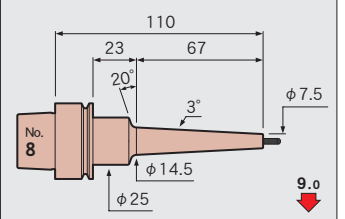

φ3.175

E40-SLSA3.175-50-M22

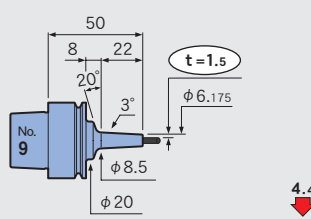

φ4

E40-SLSA4-50-M22

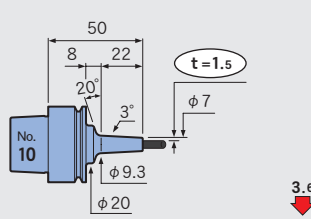

E40-SLSA4-70-M42

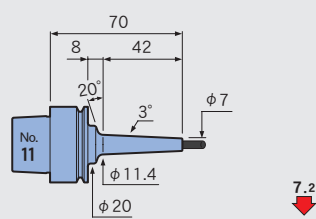

E40-SLSA4-85-M42

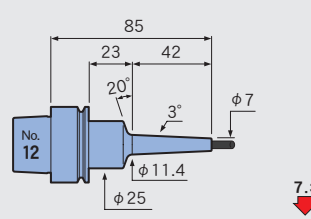

E40-SLSA4-110-M67

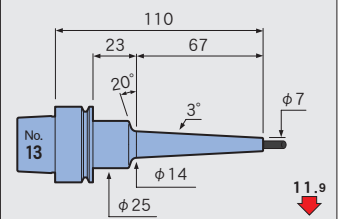

E40-SLRA4-50-M22

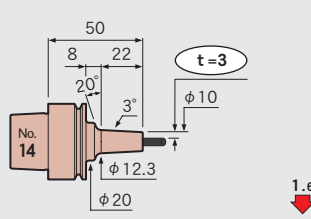

E40-SLRA4-70-M42

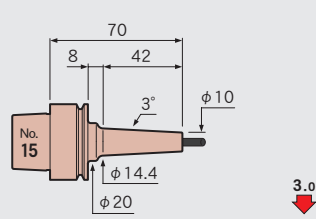

E40-SLRA4-85-M42

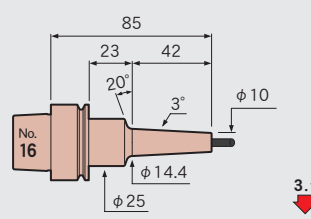

E40-SLRA4-110-M67

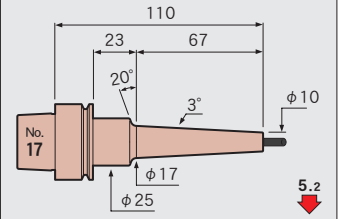

E40-SLSA4-90 CV

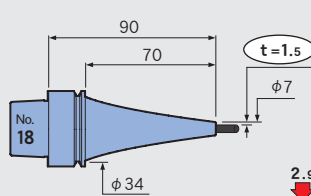

E40-SLSA4-120 CV

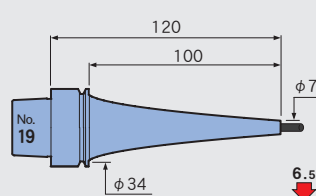

E40-SLSA4-150 CV

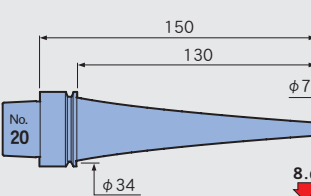

E40-SLRA4-90 CV

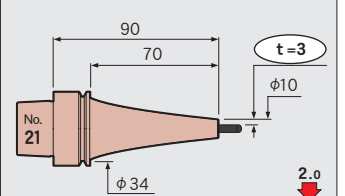

Feature
Shrink-fit Heater

MONO 3°
MONO CURVE
MONO Series

2PIECE type

UNO

HYPER version

STRAIGHT anbor

OTHERS

PERIPHERALS

Technical Information

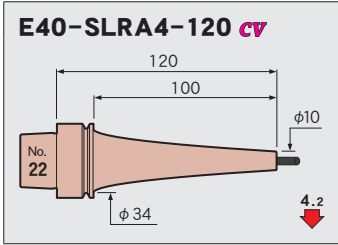

φ 3/16

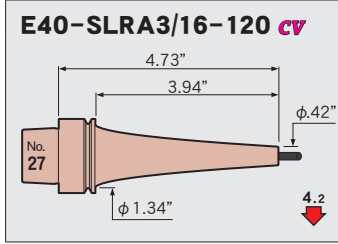
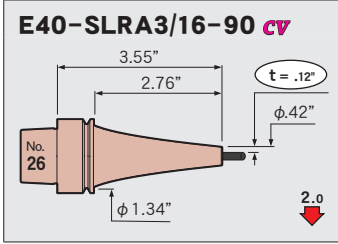
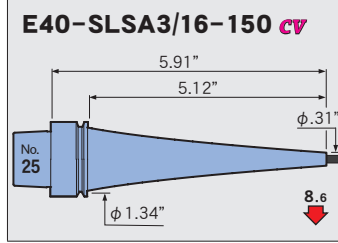
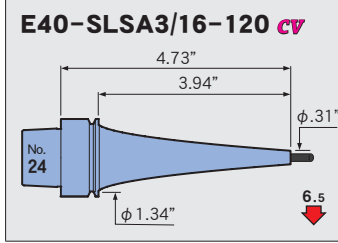
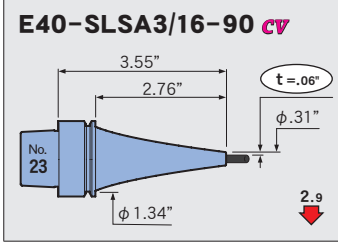

φ 6

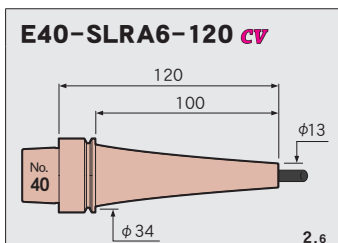
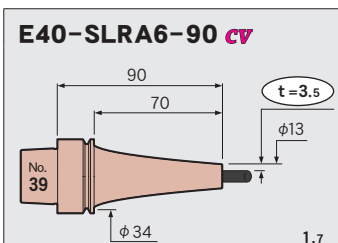
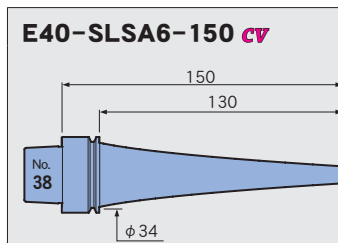
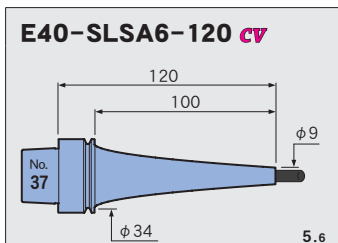
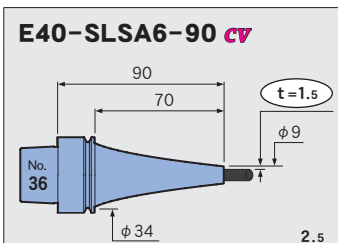
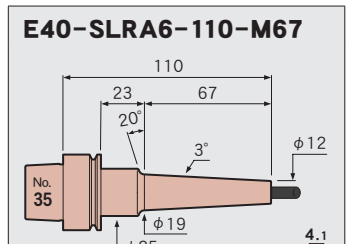
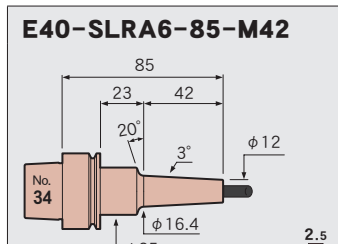
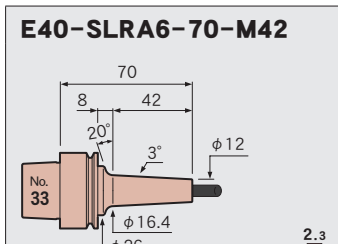
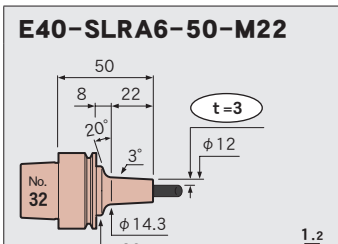
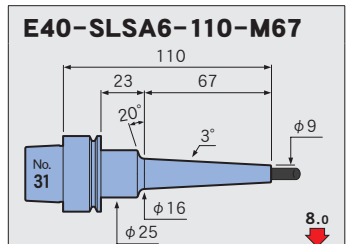
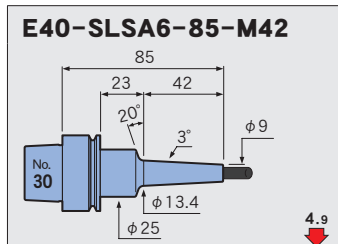
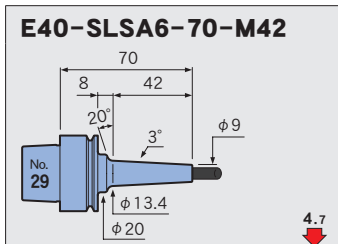
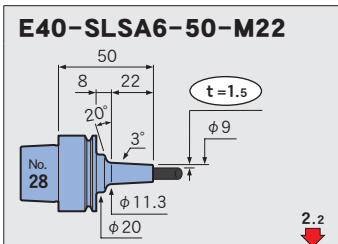

$\phi 1/4$

Feature

Shrink-fit Heater

MONO 3°
MONO CURVE

MONO Series

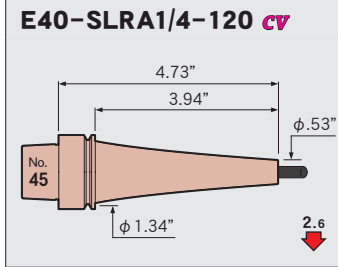
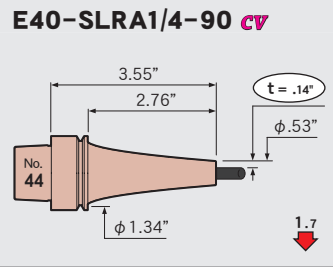
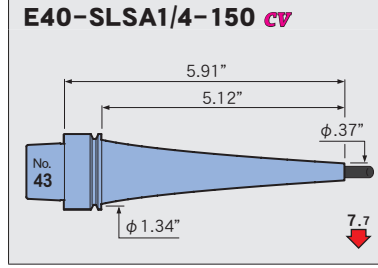
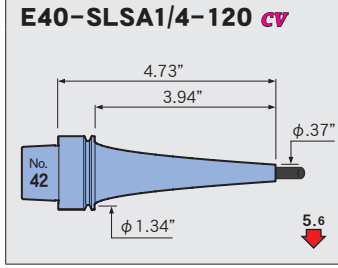
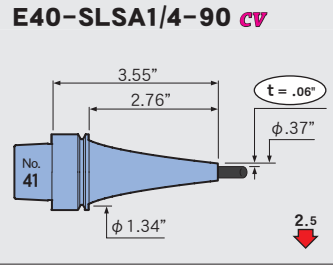

$\phi 8$

2PIECE type

UNO

HYPER version

STRAIGHT anbor

OTHERS

PERIPHERALS

Technical Information

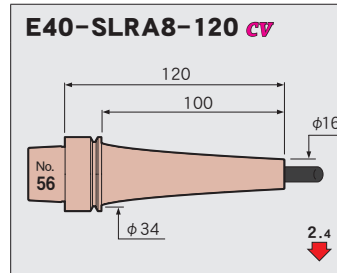
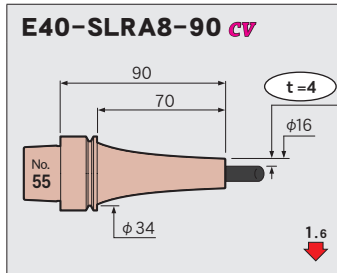
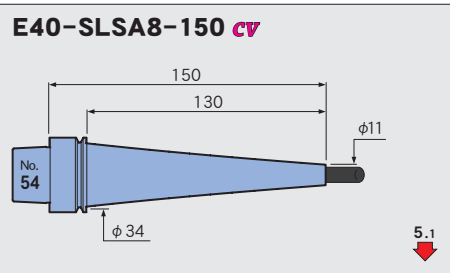
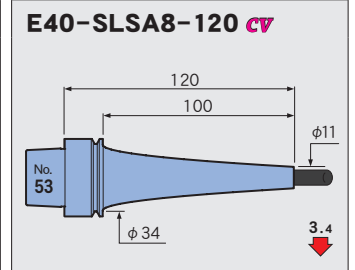
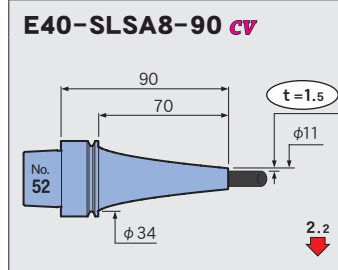
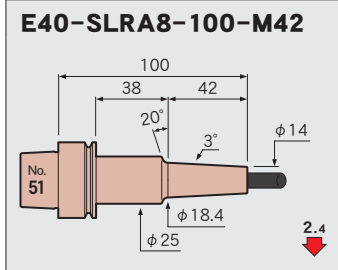
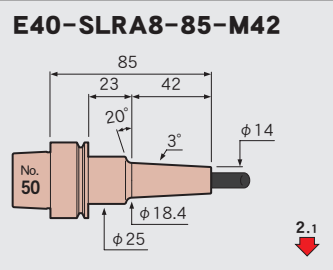
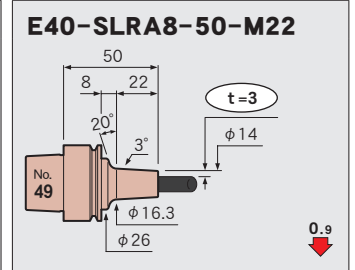
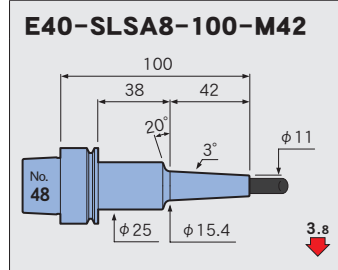
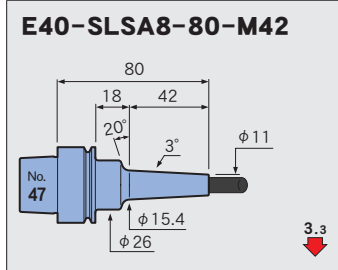
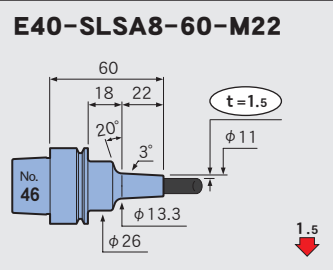

$\phi 5/16$

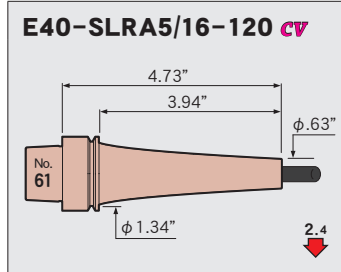
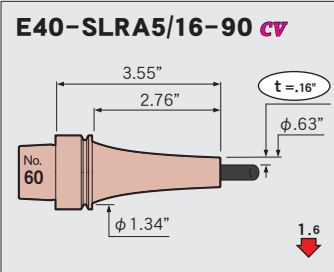
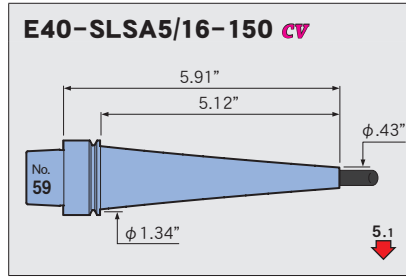
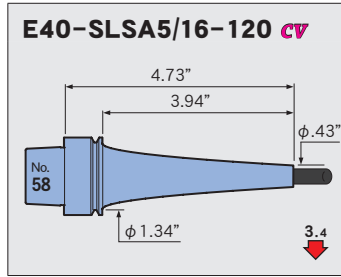
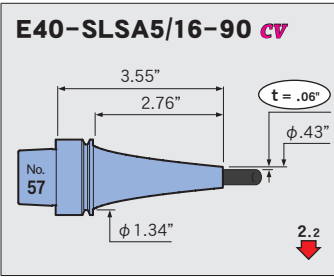

$\phi 10$

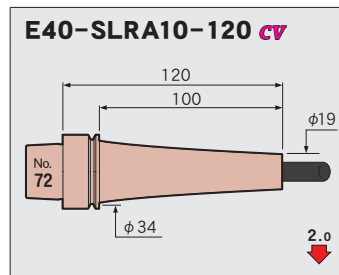
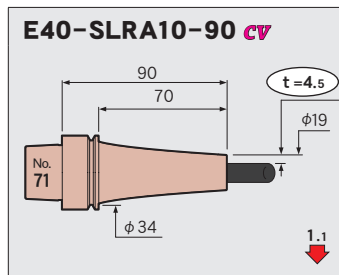
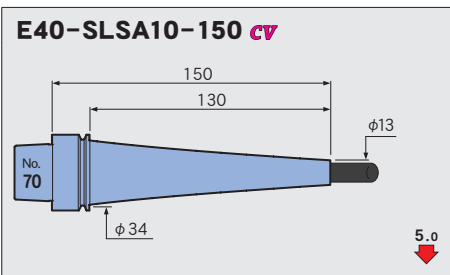
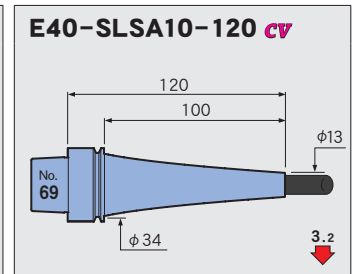
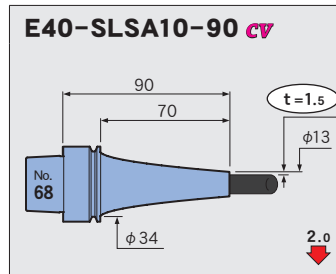
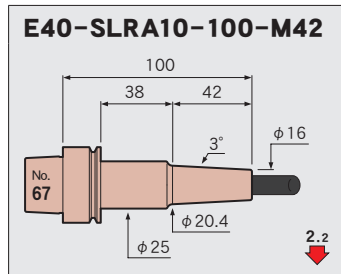
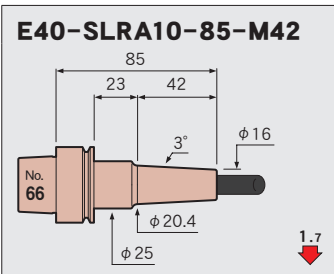
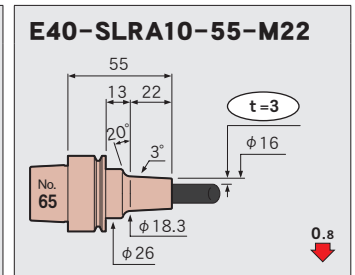
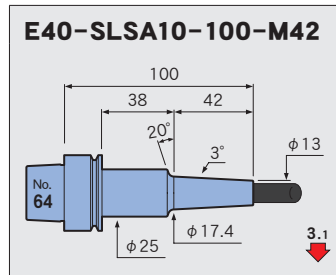
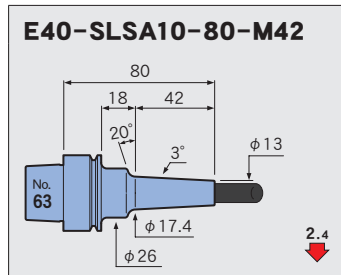
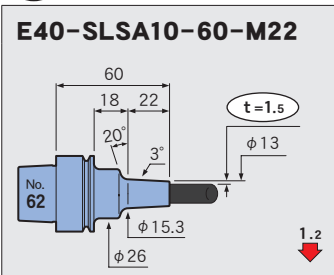

Shrink-fit Heater

MONO Series
MONO 3°
MONO CURVE

2PIECE type

UNO

HYPER
version

STRAIGHT
arbor

OTHERS

PERIPHERALS

Technical
Information

$\phi 3/8$

E40-SLSA3/8-90 CV

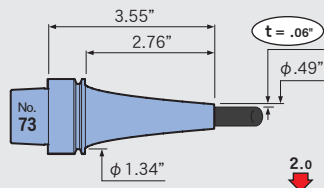

E40-SLSA3/8-120 CV

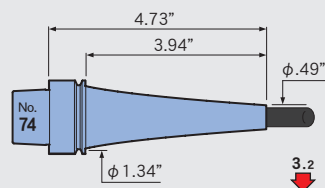

E40-SLSA3/8-150 CV

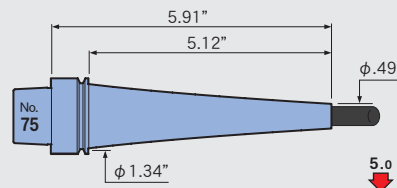

E40-SLRA3/8-90 CV

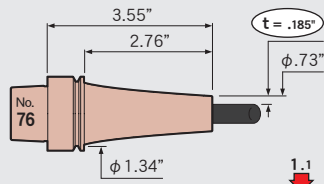

E40-SLRA3/8-120 CV

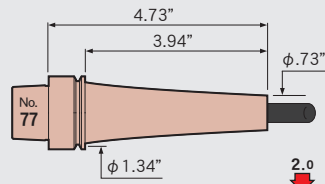

$\phi 12$

E40-SLRA12-55-M22

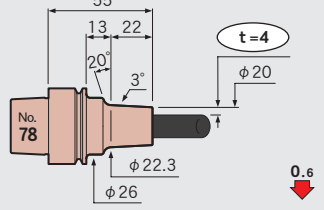

E40-SLRA12-85-M42

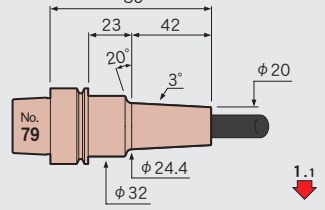

$\phi 16$

E40-SLRA16-55-M22

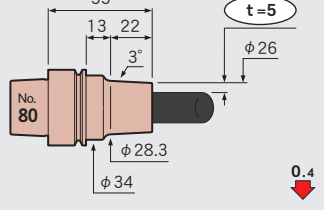

$\phi 20$

E40-SLRA20-60-M40

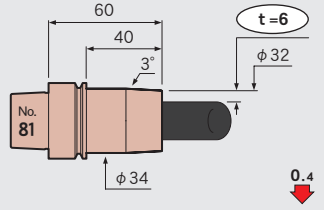

Feature

Shrink-fit Heater

MONO 3°
MONO CURVE

MONO Series

2PIECE type

UNO

HYPER version

STRAIGHT arbor

OTHERS

PERIPHERALS

Technical Information

E50

MONO 3°

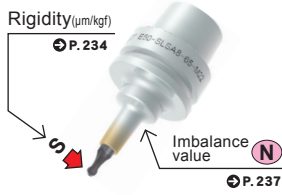

E50-SLSA8-65-M22

Fig. 1

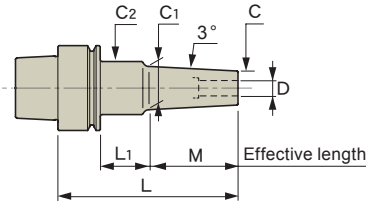

MONO CURVE CV



E50-SLSA6-150 cv

Fig. 2

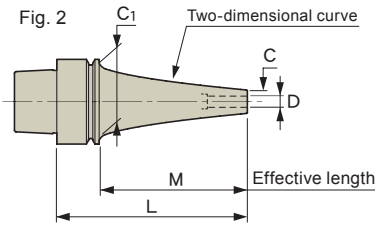

Caution

- The coolant duct is not installed in a holder. Consult us if you need it.
- Setting cutters... Be sure to insert the tool beyond the safety mark.

Compatibility table for HRD-01S

[O] Available [X] Not available

CODE	Fig.	φD	φC	t	L	M	L1	φC1	φC2	H	h	Kg	N	S	Scale model	
E50-SLSA3- 60-M22	1	3	6	1.5	60	22	12	8.3	20	9	50	0.4	1.3	4.7	○	1
- 75-M22					27		25				61					0.5
- 80-M42					12	10.4	20	70	1.7		9.3	3				
- 95-M42					27	25	81	9.1			4					
-SLRA3- 75-M22	1	3	7.5	2.25	75	22	27	9.8	25	9	61	0.5	1.7	2.8	○	5
- 95-M42					42						11.9					81
-120-M67					67	14.5	106	1.8	8.9		7					
-150-M97					97	17.7	136	0.6	12.9		8					
-SLFB3- 75-M22	1	3	9.5	3.25	75	22	27	11.8	25	9	61	0.5	1.8	1.9	○	9
E50-SLSA4- 75-M22	1	4	7	1.5	75	22	27	9.3	25	12	61	0.5	1.3	3.6	○	10
- 95-M42					42						11.4					81
-SLRA4- 75-M22	1	4	10	3	75	22	27	12.3	25	12	61	0.5	1.7	1.7	○	13
- 95-M42					42						14.4					81
-120-M67					67	17	106	0.6	5.2		15					
-150-M97					97	20.2	135	0.7	7.8		16					
-SLFB4- 75-M22	1	4	12	4	75	22	27	14.3	25	12	61	0.5	1.9	1.4	○	12
-SLSA4- 90 CV	2	4	7	1.5	90	64	—	42	—	12	74	0.6	2.2	1.8	○	17
-120 CV					94											104
-150 CV					124	134					0.7	3.3	6	19		
-180 CV					154	164					0.8	3.5	12	20		
-SLRA4-120 CV	2	4	10	3	120	94	—	42	—	12	104	0.7	2.8	2.7	○	21
-150 CV					124											134



CODE	Fig.	φD	φC	t	L	M	L1	φC1	φC2	H	h	Kg lbs	N	S	Scale model
E50-SLSA3/16- 90 CV	2	3/16	.31	.06	3.55	2.52	—	1.65	—	0.59	2.83	1.4	2.6	1.7	23
-120 CV					4.73	3.71					4.02	1.4	2.8	4.2	24
-150 CV					5.91	4.89					5.20	1.7	3.5	6	25
-180 CV					7.09	6.07					6.38	1.7	3.7	12	26
-SLRA3/16-120 CV	2	3/16	.42	.12	4.73	3.71	—	1.65	—	0.59	4.02	1.6	3.4	2.7	27
-150 CV					5.91	4.89					5.20	1.7	3.6	4.1	28
E50-SLSA6- 75-M22	1	6	9	1.5	75	22	27	11.3	25	18	61	0.5	1.3	2.3	29
- 95-M42					95	42		13.4			81		1.6	4.8	30
-120-M67					120	67		16			106		1.8	8.1	31
-150-M97					150	97		19.2	32		135	0.6	2.3	11	32
-SLSB6- 95-M42	1	6	10	2	95	42	27	14.4	25	18	81	0.5	1.8	3.7	33
-120-M67					120	67		17			106	0.6		6.2	34
-150-M97					150	97		20.2	32		135	0.7	2.3	8.5	35
-SLRA6- 75-M22	1	6	12	3	75	22	27	14.3	25	18	61	0.5	1.5	1.3	36
- 95-M42					95	42		16.4			81		1.8	2.5	37
E50 -120-M67					120	67		19			106	0.6	1.9	4.1	38
-SLRB6- 95-M42	1	6	14	4	95	42	27	18.4	32	18	80	0.6	2.2	1.6	39
-SLFB6- 75-M22	1	6	14	4	75	22	27	16.3	32	18	60	0.6	2.1	1	40
-SLSA6- 90 CV	2	6	9	1.5	90	64	—	42	—	18	74	0.6	2.3	1.6	41
-120 CV					120	94					104		2.7	3.5	42
-150 CV					150	124					134	0.7	3.4	5.4	43
-180 CV					180	154					164	0.9	4.2	7.6	44
-SLRA6-120 CV	2	6	13	3.5	120	94	—	42	—	18	104	0.8	3.3	1.8	45
-150 CV					150	124					132	0.9	4	2.7	46
E50-SLSA1/4- 90 CV	2	1/4	.37	.06	3.55	2.52	—	1.65	—	0.71	2.83	1.4	2.6	1.6	47
-120 CV					4.73	3.71					4.02	1.4	2.9	3.5	48
-150 CV					5.91	4.89					5.20	1.7	3.6	5.4	49
-180 CV					7.09	6.07					6.38	1.9	4.3	7.6	50
-SLRA1/4-120 CV	2	1/4	.53	.14	4.73	3.71	—	1.65	—	0.71	4.02	1.6	3.4	1.8	51
-150 CV					5.91	4.89					5.20	2	4.2	2.7	52
E50-SLSA8- 65-M22	1	8	11	1.5	65	22	17	13.3	26	24	49	0.5	1.5	1.5	53
- 75-M22					75		27	15.4	25		61		1.6	1.6	54
- 85-M42					85	42	17		26		67			3.2	55
- 95-M42					95		27		25		81		2.2	3.5	56
-120-M67					120	67		18	32		105	0.6	2.3	5.4	57
-150-M97					150	97		21.2			132	0.7	2.4	8.1	58
-SLSB8- 95-M42	1	8	13	2.5	95	42	27	17.4	32	24	80	0.6	2.2	2.1	59
-120-M67					120	67		20			105		2.3	3.5	60
-150-M97					150	97		23.2			135	0.7	2.4	5.3	61



Feature
Shrink-fit Heater
MONO 3° MONO CURVE
MONO Series
2PIECE type
UNO
HYPER version
STRAIGHT arbor
OTHERS
PERIPHERALS
Technical Information

CODE	Fig.	φD	φC	t	L	M	L ₁	φC ₁	φC ₂	H	h		N	S		Scale model	
E50-SLRA8- 75-M22	1	8	14	3	75	22	27	16.3	25	24	61	0.5	1.5	1.1		63	
- 95-M42					95	42		18.4			81		1.8	2		64	
-SLRB8- 95-M42	1	8	18	5	95	42	27	22.4	32	24	80	0.6	2.2	1.1		65	
-120-M67					120	67		25			105		0.7	2.3		1.7	66
-SLFB8- 75-M22	1	8	18	5	75	22	27	20.3	32	24	60	0.6	2.2	0.7		67	
-SLSA8- 90 CV	2	8	11	1.5	90	64	—	42	—	24	74	0.6	2.5	1.4		68	
-120 CV					120	94					104		0.7	3.2		2.2	69
E50 -150 CV					150	124					134			3.5		4.9	70
-180 CV					180	154					164		0.8	4.2		7.1	71
-SLRA8-120 CV	2	8	16	4	120	94	—	42	—	24	102	0.8	3.8	1.3		72	
-150 CV					150	124					132		0.9	4		2.7	73
E50-SLSA5/16- 90 CV	2	5/16	.43	.06	3.55	2.52	—	1.65	—	0.94	2.83	1.4	2.6	1.4		74	
-120 CV					4.73	3.71					4.02		1.6	3.4		2.2	75
-150 CV					5.91	4.89					5.20		1.7	3.6		4.9	76
-180 CV					7.09	6.07					6.38		1.9	4.4		7.1	77
-SLRA5/16-120 CV	2	5/16	.63	.16	4.73	3.71	—	1.65	—	0.94	4.02	1.8	4	1.3		78	
-150 CV					5.91	4.89					5.20		1.9	4.2		2.7	79
E50-SLSA10- 65-M22	1	10	13	1.5	65	22	17	15.3	26	30	49	0.5	1.5	1.1		80	
- 75-M22					75		27		25		61		1.6	1.3		81	
- 85-M42					85	42	17	17.4	26		64			2.4		82	
- 95-M42					95		27		25		81		2.2	2.6		83	
-120-M67					120	67		20	32		105		0.6	2.3		4.1	84
-150-M97					150	97		23.2			64		0.7	2.5		6.2	85
-SLSB10- 95-M42	1	10	16	3	95	42	27	20.4	32	30	80	0.6	2.2	1.5		86	
-120-M67					120	67		23			105		0.7	2.4		2.4	87
-150-M97					150	97		26.2			135			2.5		3.7	88
-SLRA10- 75-M22	1	10	16	3	75	22	27	18.3	25	30	60	0.6	1.5	1		89	
-SLRB10- 95-M42	1	10	22	6	95	42	27	26.4	32	30	80	0.7	2.3	0.9		90	
-120-M67					120	67		29			42		107	0.8		3.2	1.1
-SLFB10- 75-M22	1	10	22	6	75	22	27	24.3	32	30	60	0.6	2.2	0.6		92	
-SLSA10- 90 CV	2	10	13	1.5	90	64	—	42	—	30	74	0.6	2.5	1.3		93	
-120 CV					120	94					104		0.7	3.3		2.1	94
-150 CV					150	124					134		0.8	4.1		3.4	95
-180 CV					180	154					162			4.3		6.9	96
-SLRA10-150 CV	2	10	19	4.5	150	124	—	42	—	30	132	0.9	4.4	2.2		97	
E50-SLSA3/8- 90 CV	2	3/8	.49	.06	3.55	2.52	—	1.65	—	1.18	2.83	1.4	2.6	1.3		98	
-120 CV					4.73	3.71					4.02		1.6	3.4		2.1	99
-150 CV					5.91	4.89					5.20		1.9	4.2		3.4	100
-180 CV					7.09	6.07					6.38		1.9	4.5		6.9	101
-SLRA3/8-150 CV	2	3/8	.73	.185	5.91	4.89	—	1.65	—	1.18	5.20	2.0	4.7	2.2		102	



Feature
Shrink-fit Heater
MONO 3° MONO CURVE
MONO Series
2PIECE type
UNO
HYPER version
STRAIGHT arbor
OTHERS
PERIPHERALS
Technical information

CODE	Fig.	ϕD	ϕC	t	L	M	L ₁	ϕC_1	ϕC_2	H	h	Kg	N	S	Scale model
E50-SLSA12- 65-M22	1	12	15	1.5	65	22	17	17.3	26	25	49	0.5	1.6	0.9	103
- 75-M22					75		27		25	30	60		1.7	1.1	104
E50 - 95-M42					95	42		19.4	32		80		2.2	1.9	105
-120-M67					120	67		22			105	0.6	2.4	3.3	106
-SLSB12- 95-M42	1	12	19	3.5	95	42	27	23.4	32	30	80	0.6	2.3	1.2	107
-120-M67					120	67		26			105	0.7	2.5	1.9	108
-150-M97					150	97		29.2			135	0.9	3.5	2.5	109
-SLRA12- 75-M22	1	12	20	4	75	22	27	22.3	25	30	62	0.6	1.6	0.9	110
-SLRB12- 95-M42	1	12	26	7	95	42	27	30.4	42	30	82	0.8	3.1	0.6	111
-120-M67					120	67		33			107	0.9	3.3	0.9	112
-SLFB12- 75-M22	1	12	26	7	75	22	27	28.3	42	30	62	0.7	3	0.4	113
E50-SLSB16- 95-M42	1	16	24	4	95	42	27	28.4	42	32	82	0.7	3.2	0.7	114
-120-M67					120	67		31			107	0.8	3.5	1.2	115
-SLRA16- 60-M22	1	16	26	5	60	22	12	28.3	34	32	44	0.6	1.7	0.4	116
-SLRB16- 75-M22	1	16	32	8	75	22	27	34.3	42	32	62	0.7	3	0.4	117
-SLFB16- 75-M22	1	16	32	8	75	22	27	34.3	42	32	62	0.7	3	0.4	118
E50-SLSB20- 95-M42	1	20	29	4.5	95	42	27	33.4	42	40	82	0.7	3.3	0.6	119
-SLRA20- 65-M22	1	20	32	6	65	22	17	34.3	40	38	49	0.6	2.2	0.3	120

SLFB 

■ Cleaning tool for a spindle taper hole, STAR DUST

CODE
CLT-E50-G2

● P.226



DMG MORI
MAKINO
NIDEC
ROKU-ROKU

HSC 70 linear
V33i / D200Z
 $\mu V5$
ZEUS-86



Feature

Shrink-fit Heater

MONO 3°
MONO CURVE

MONO Series

2PIECE type

UNO

HYPER
versionSTRAIGHT
arbor

OTHERS

PERIPHERALS

Technical
Information

φ 3

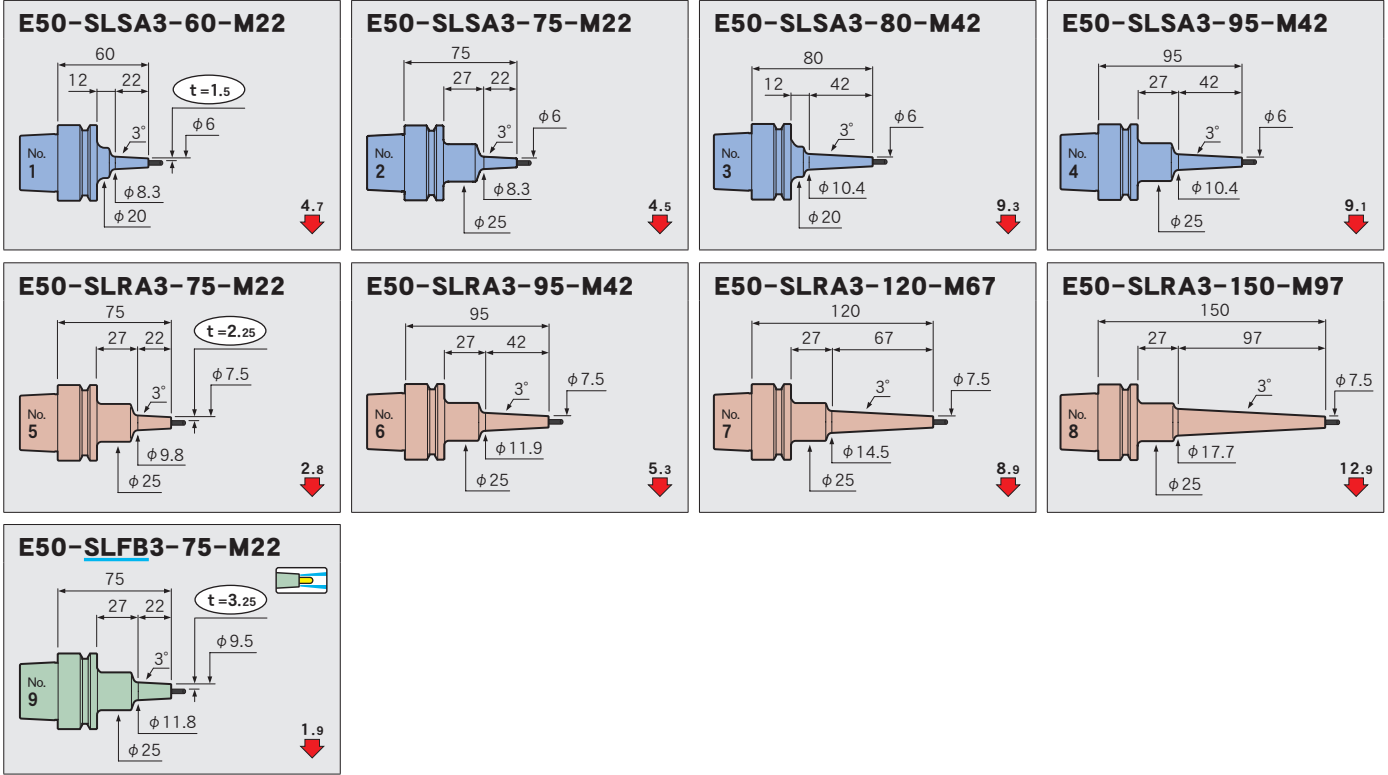

φ 4

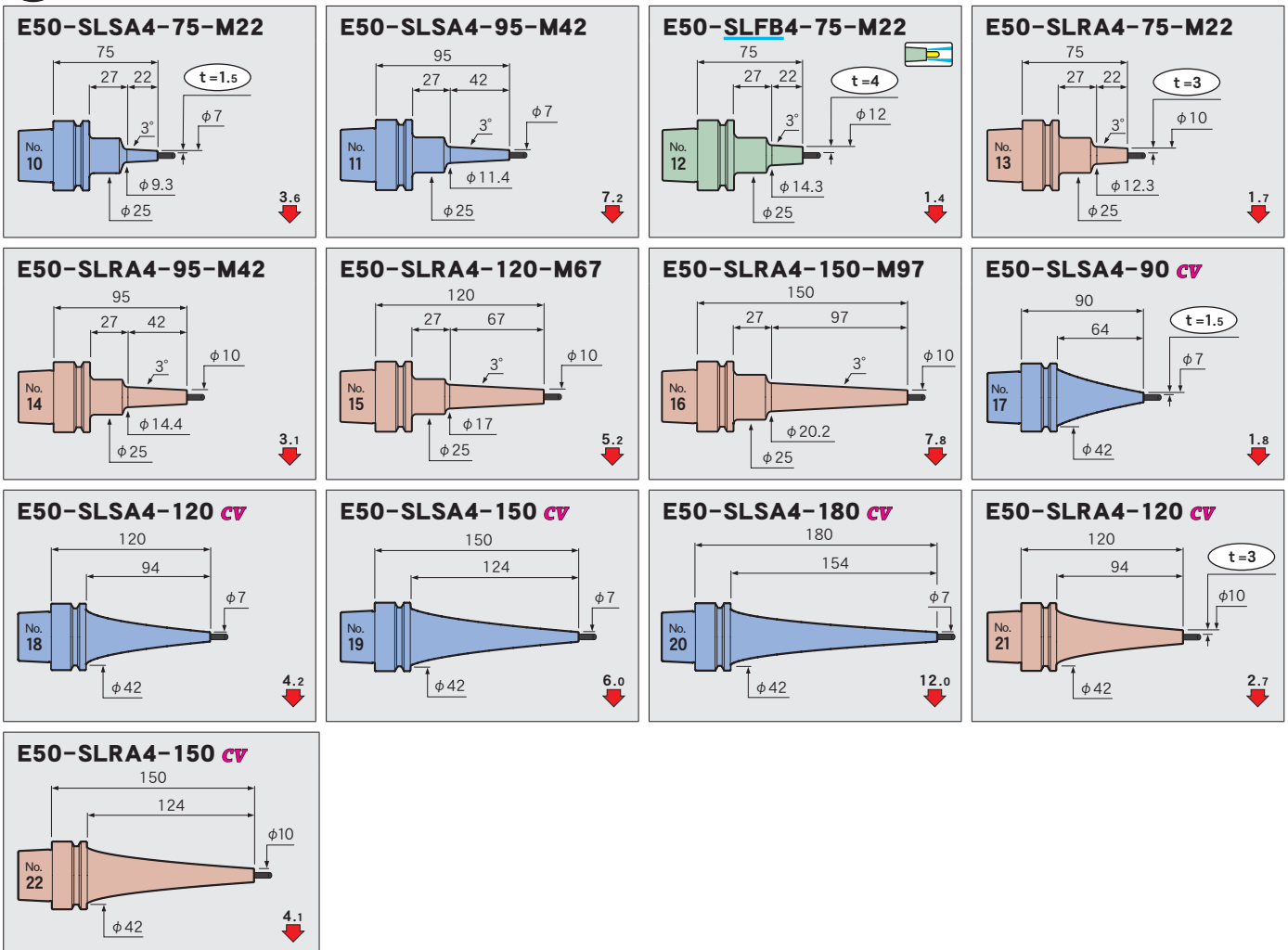

Feature
Shrink-fit Heater

MONO 3°
MONO CURVE
MONO Series

2PIECE type

UNO

HYPER
version

STRAIGHT
arbor

OTHERS

PERIPHERALS

Technical
Information

$\phi 3/16$

Feature
Shrink-fit Heater

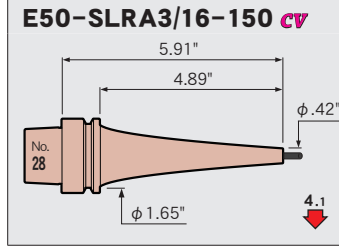
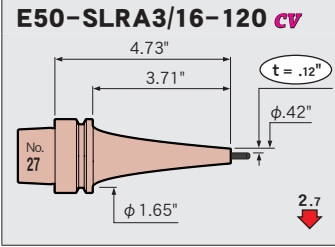
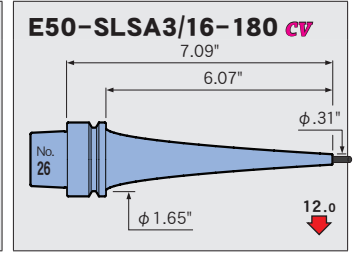
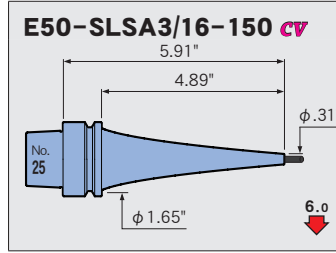
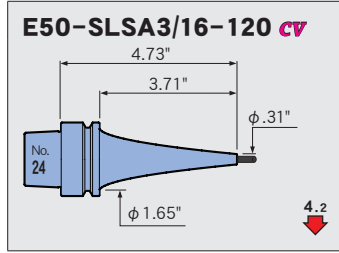
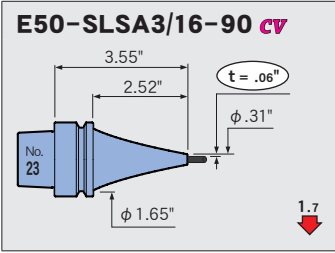

MONO 3°
MONO CURVE
MONO Series

2PIECE type

$\phi 6$

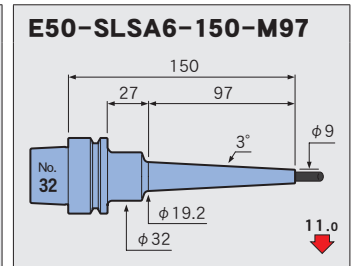
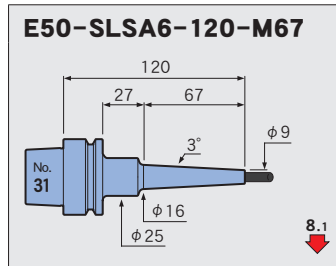
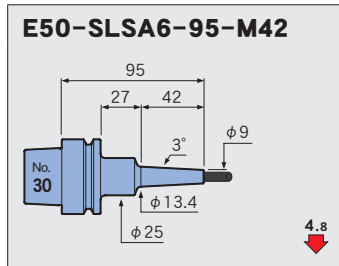
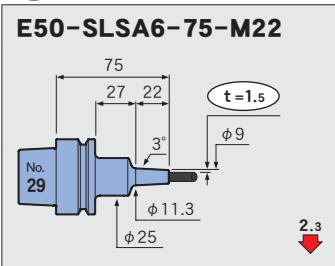

UNO

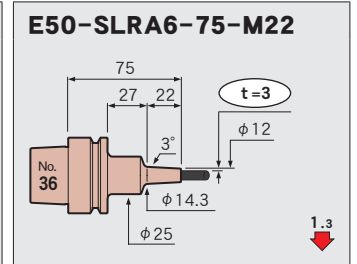
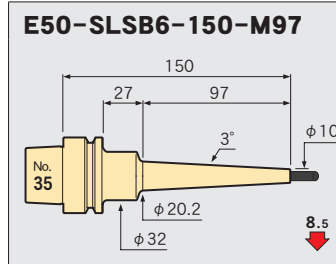
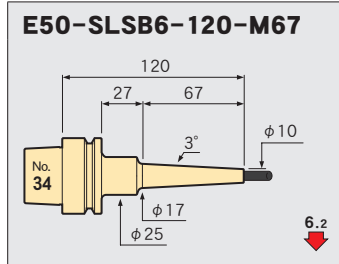
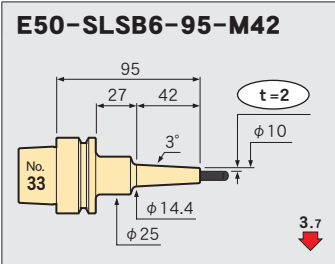

HYPER version

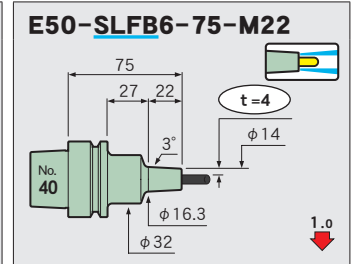
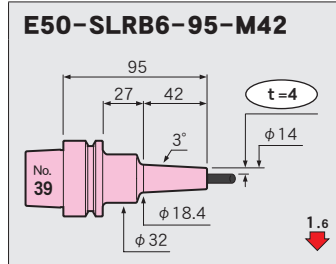
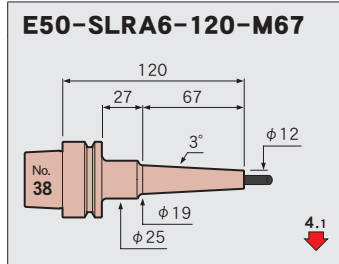
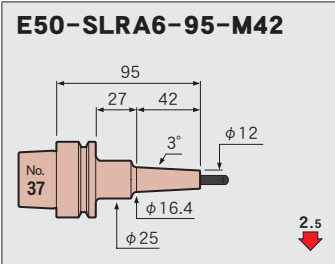

STRAIGHT anbor

OTHERS

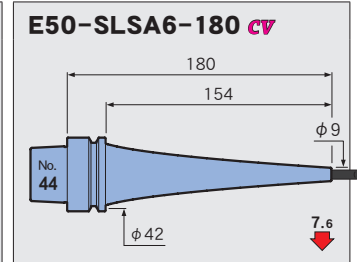
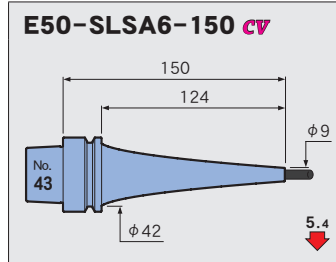
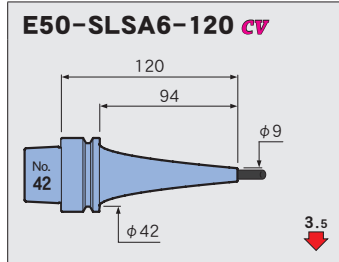
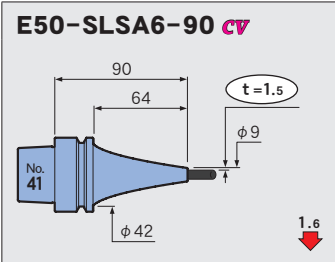

PERIPHERALS

Technical Information

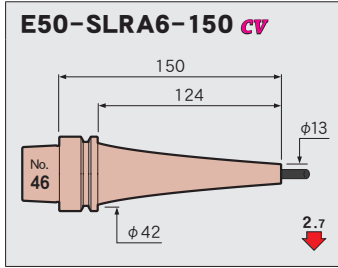
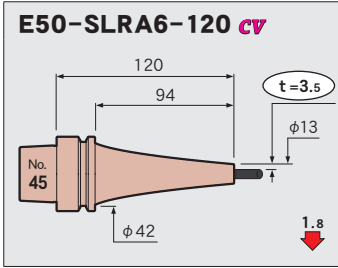

φ 1/4

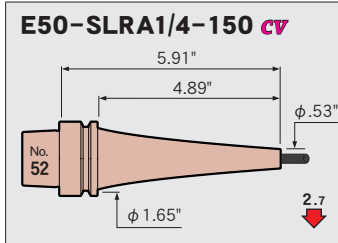
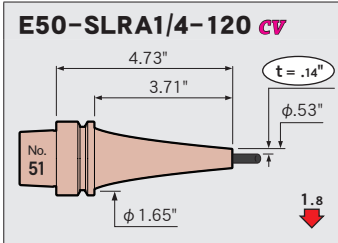
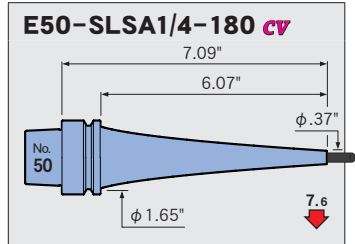
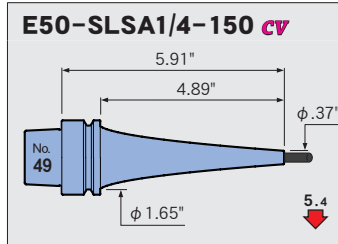
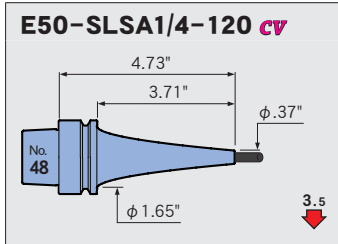
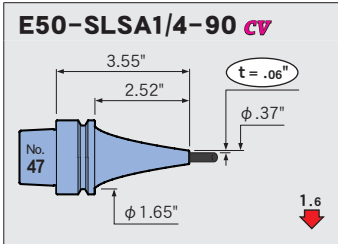

φ 8

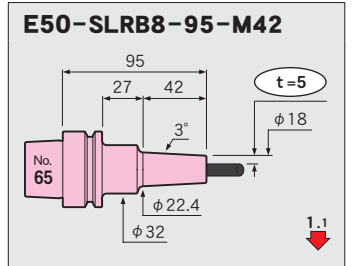
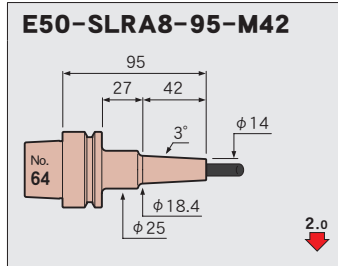
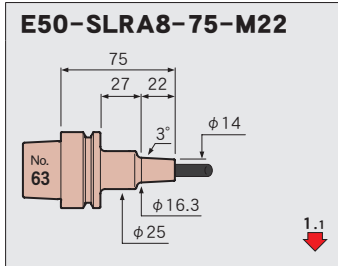
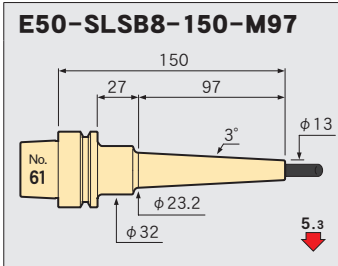
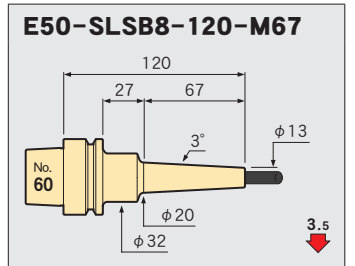
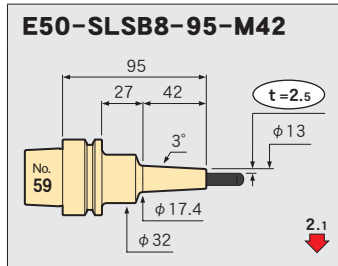
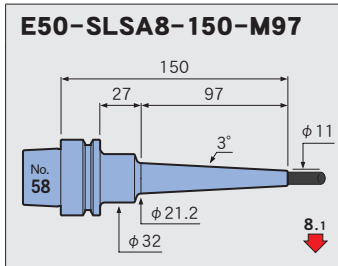
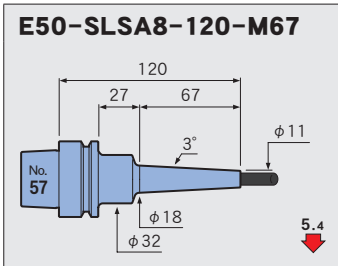
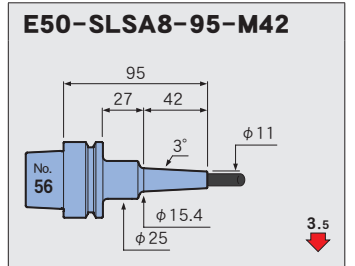
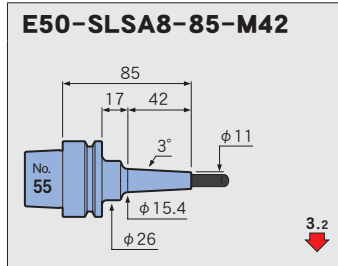
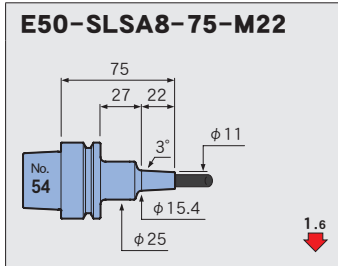
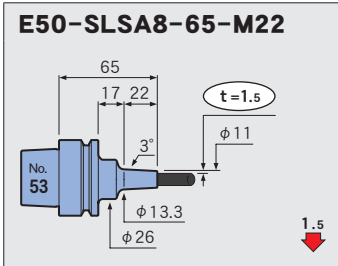

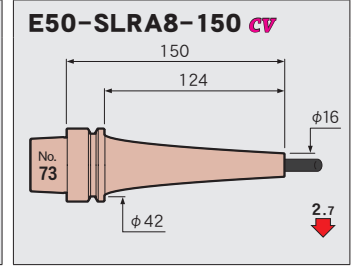
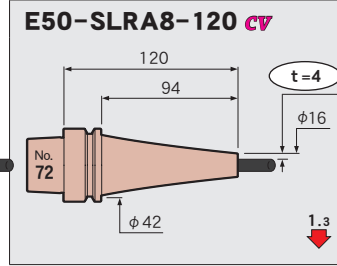
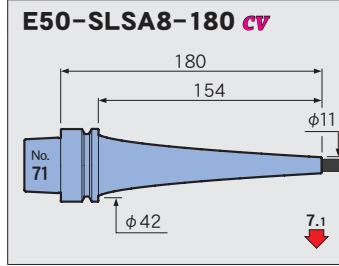
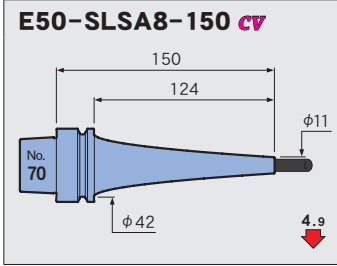
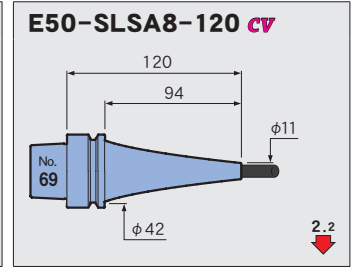
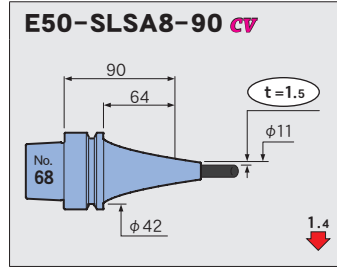
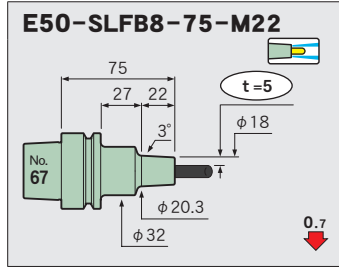
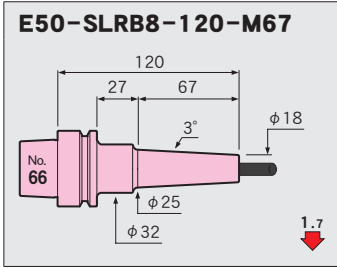

φ 5/16

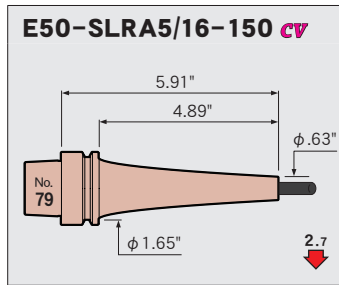
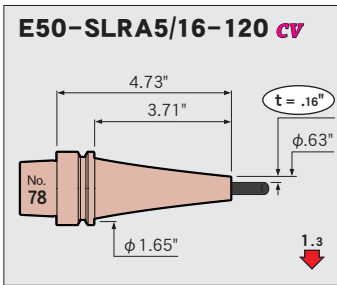
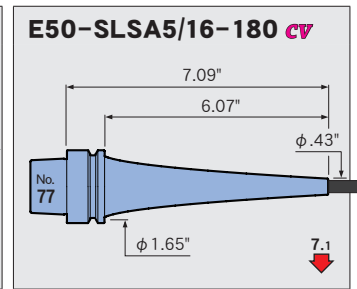
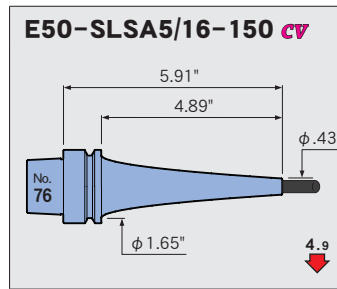
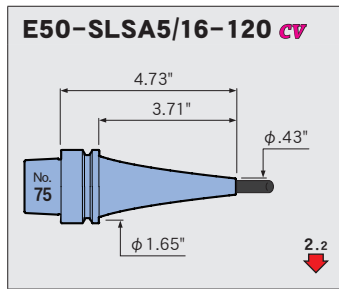
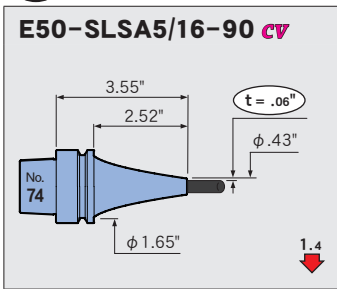

φ 10

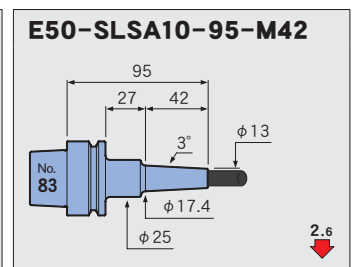
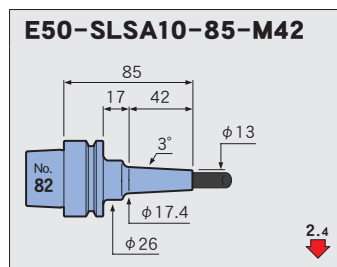
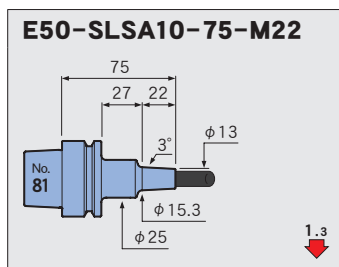
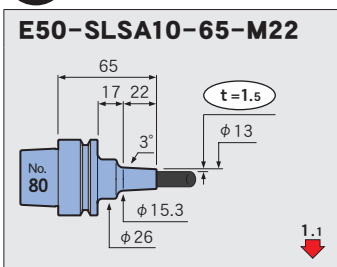

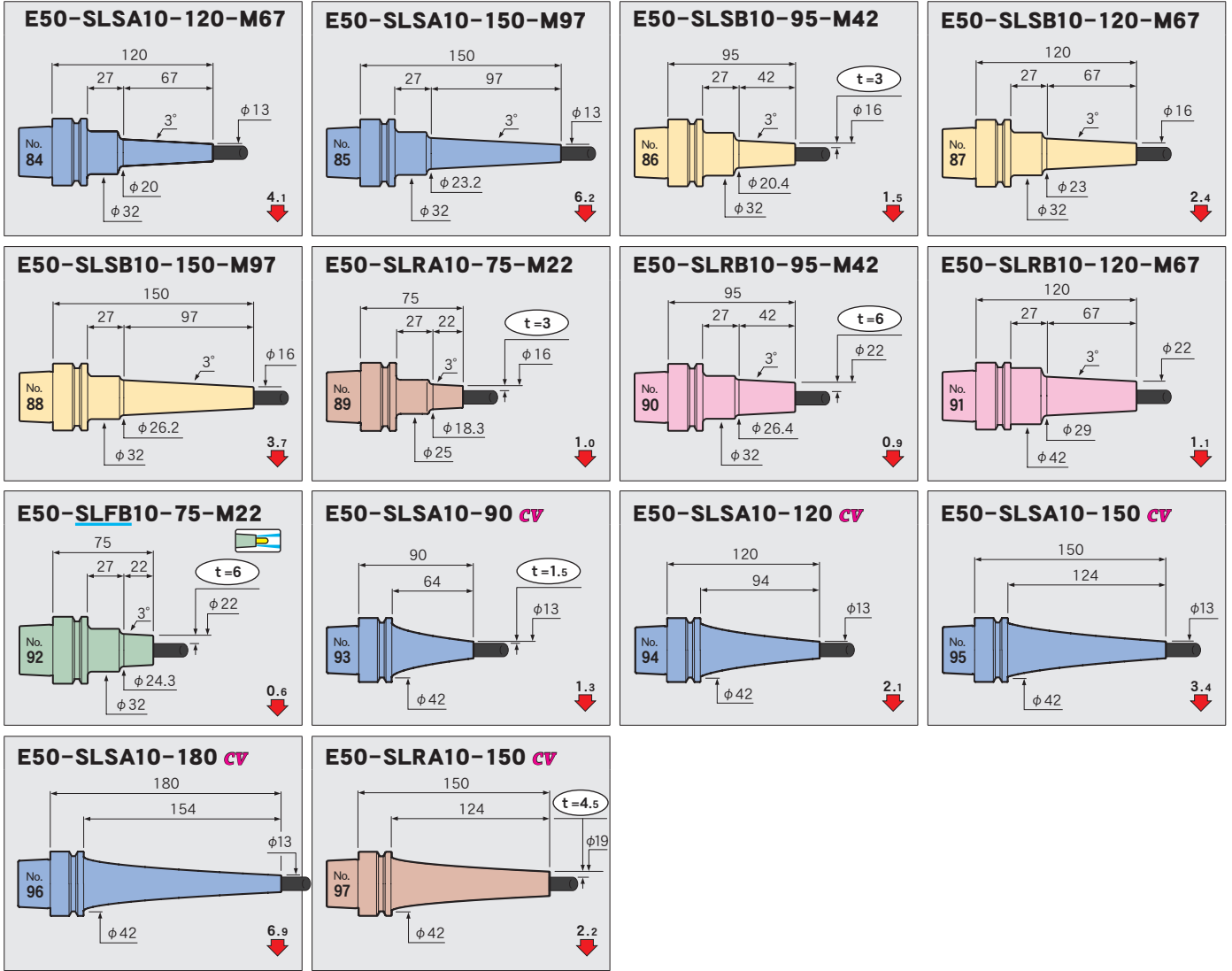

3/8

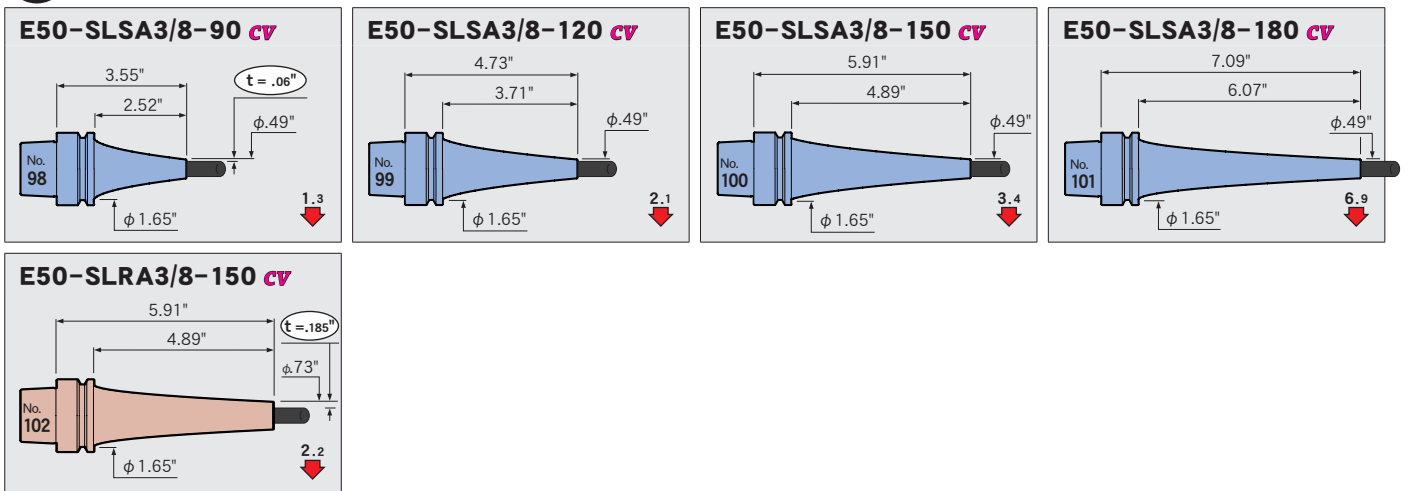

Feature

Shrink-fit Heater

MONO 3°
MONO CURVE

MONO Series

2PIECE type

UNO

HYPER
version

STRAIGHT
arbor

OTHERS

PERIPHERALS

Technical
Information

φ12

Feature
Shrink-fit Heater

MONO 3°
MONO CURVE

MONO Series

2PIECE type

UNO

HYPER version

STRAIGHT arbor

OTHERS

PERIPHERALS

Technical Information

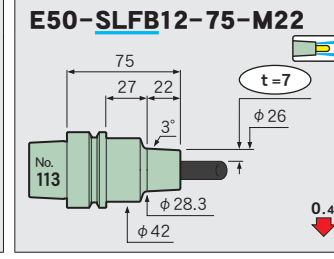
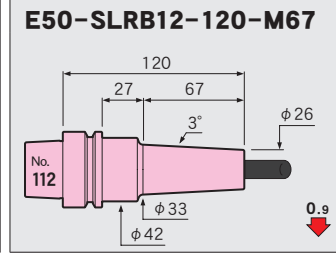
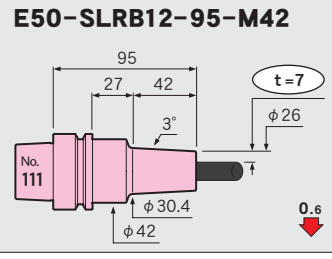
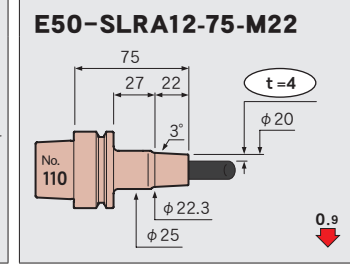
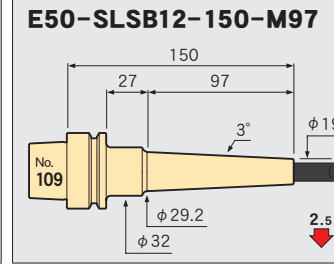
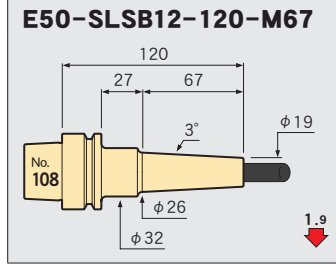
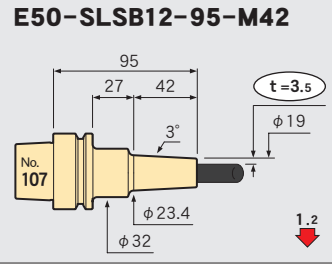
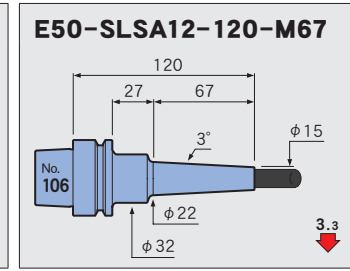
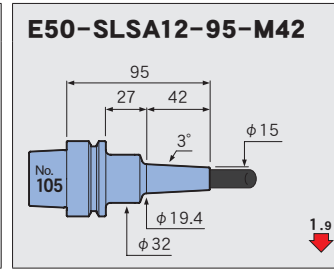
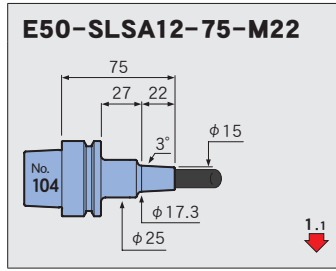
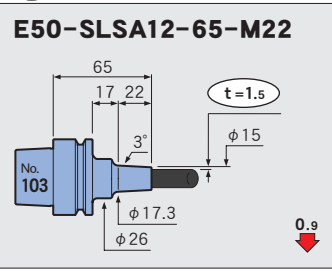

φ16

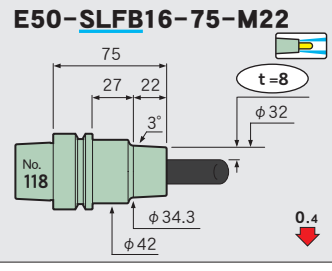
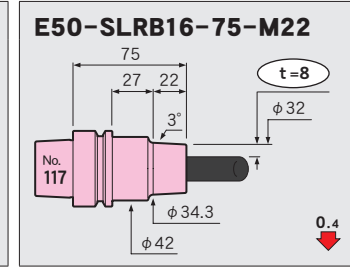
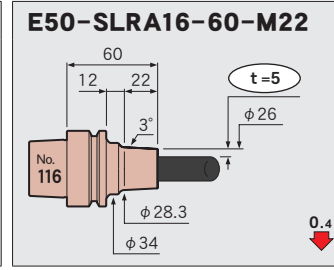
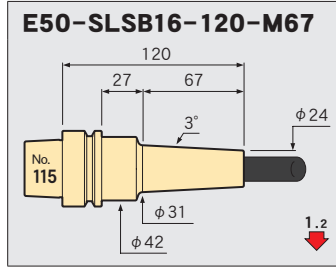
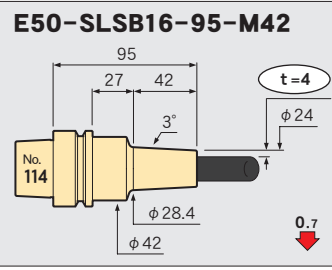

φ20

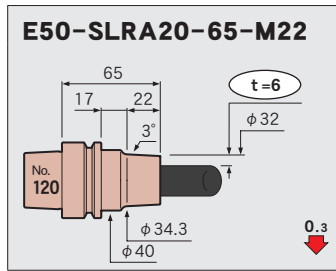
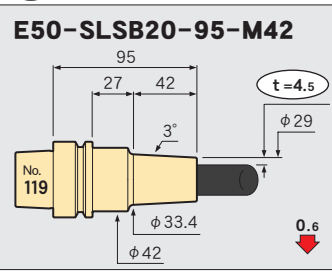

F63

MONO 3°

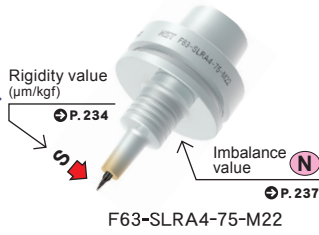
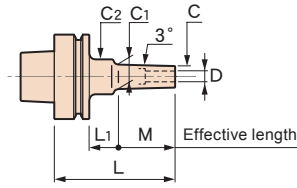
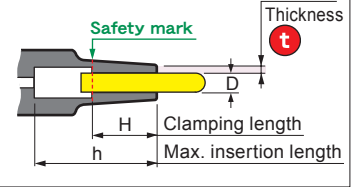

Fig. 1



Caution

- The coolant duct is not installed in a holder. Consult us if you need it.
- Setting cutters: Be sure to insert the tool beyond the safety mark.



MONO CURVE CV



Fig. 2

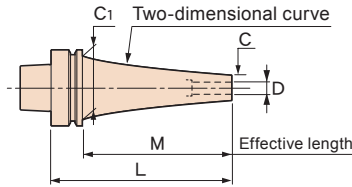

Compatibility table for HRD-01S

- [O] Available [x] Not available
- [▲] Usable by raising the heating unit. →P.233
- [★] Use heating coil No. 2.

CV : Curve

Thickness

CODE	Fig.	φD	φC	t	L	M	L ₁	φC ₁	φC ₂	H	h	Kg lbs	(N)	S	Scale model	
F63-SLSA3- 95-M42	1	3	6	1.5	95	42	27	10.4	25	9	78	0.7	1.8	9.1	○	2
-SLRA3- 75-M22	1	3	7.5	2.25	75	22	27		25	9	54	0.7	1.8	2.8	○	4
- 95-M42					95	42		11.9			78		1.9	5.3		5
-SLFB3- 75-M22	1	3	9.5	3.25	75	22	27	11.8	25	9	58	0.7	1.9	1.9	○	6
- 95-M42					95	42		13.9			78	0.8	2	3.2		7
-120-M67					120	67		16.5			103			5.4		8
F63-SLSA4- 95-M42	1	4	7	1.5	95	42	27	11.4	25	12	78	0.7	1.9	7.2	○	9
-SLRA4- 75-M22	1	4	10	3	75	22	27	12.3	25	12	58	0.7	1.8	1.7	○	10
- 95-M42					95	42		14.4			78	0.8	1.9	3.1		11
-SLFB4- 75-M22	1	4	12	4	75	22	27	14.3	25	12	58	0.7	2	1.3	○	12
- 95-M42					95	42		16.4			78	0.8		2.2		13
-120-M67					120	67		19			103		2.1	3.6		14
-SLSA4- 90 CV	2	4	7	1.5	90	64	—	53	—	12	65	0.9	2.7	1.8	○	15
-120 CV					120	94					95	1	3.6	2.7		16
-150 CV					150	124					125	1.2	4.4	4		17
-180 CV					180	154					154	1.3	5	6.6		18
-210 CV					210	184					185		5.3	11.6		19
-240 CV					240	214					214	1.6	6.5	14		20
-270 CV					270	244					245	1.9	8.8	11.9		21
-300 CV					300	274					275	2	9.7	15.9		22
-SLRA4-120 CV	2	4	10	3	120	94	—	53	—	12	95	1	3.6	1.9	○	23
-150 CV					150	124					125	1.1	4.4	2.9		24
-180 CV					180	154					155	1.4	6	3.3		25
-210 CV					210	184					185	1.5	6.2	5.6		26
F63-SLSA3/16- 90 CV	2	3/16	.31	.06	3.54	2.52	—	2.09	—	.59	2.56	2	2.8	2.0	○	27
-120 CV					4.72	3.70					3.74	2.3	3.6	2.6		28
-150 CV					5.91	4.88					4.92	2.6	4.5	4.0		29
-180 CV					7.09	6.06					6.06	2.7	5.2	6.5		30
-210 CV					8.27	7.24					7.24	3.2	6.4	8.4		31
-240 CV					9.45	8.43					8.43	3.6	7.6	10.6		32
-270 CV					10.63	9.61					9.61	4	8.9	13.2		33
-300 CV					11.81	10.79					10.83	4.5	10	16.1		34



CODE	Fig.	φD	φC	t	L	M	L ₁	φC ₁	φC ₂	H	h	Kg lbs	N	S	Scale model
F63-SLRA3/16-120 CV	2	3/16	.42	.12	4.72	3.70	—	2.09	—	.59	3.70	2.3	3.8	1.8	35
-150 CV					5.91	4.88					4.88	2.7	5	2.4	36
-180 CV					7.09	6.06					6.10	2.8	5.3	4.3	37
-210 CV					8.27	7.24					7.24	2.8	5.8	5.7	38
F63-SLSA6- 95-M42	1	6	9	1.5	95	42	27	13.4	25	18	78	0.7	1.9	4.8	40
-SLSB6- 95-M42	1	6	10	2	95	42	27	14.4	25	18	78	0.7	1.9	3.7	41
-SLRA6- 75-M22	1	6	12	3	75	22	27	14.3	25	18	58	0.7	1.8	1.3	42
- 95-M42					95	42		16.4			78	0.8	1.9	2.4	43
-SLFB6- 75-M22	1	6	14	4	75	22	27	16.3	32	18	58	0.8	2.2	1	44
-SLSA6 - 90 CV	2	6	9	1.5	90	64	—	53	—	18	65	0.9	2.8	1.6	45
-120 CV					120	94					95	1	3.6	2.3	46
-150 CV					150	124					125	1.2	4.4	3.6	47
-180 CV					180	154					154	1.3	5.2	5.7	48
-210 CV					210	184					184	1.5	6.4	7.3	49
-240 CV					240	214					214	1.6	6.7	12	50
-270 CV					270	244					245	2	9.7	8.5	51
-300 CV					300	274					275	2.2	10.6	11.7	52
-SLRA 6- 90 CV	2	6	13	3.5	90	64	—	53	—	18	65	1	3.4	0.8	53
-120 CV					120	94					95	1.2	4.3	1.2	54
-150 CV					150	124					125	1.3	5.2	1.9	55
-180 CV					180	154					155	1.4	6.1	2.8	56
-210 CV					210	184					185	1.5	6.6	4.8	57
-SLFA 6- 90 CV	2	6	13	3.5	90	64	—	53	—	18	65	1	3.4	0.8	58
-120 CV					120	94					95	1.2	4.3	1.2	59
-150 CV					150	124					125	1.3	5.2	1.9	60
-180 CV					180	154					155	1.4	6.1	2.8	61
-210 CV					210	184					185	1.5	6.6	4.8	62
F63-SLSA1/4- 90 CV	2	1/4	.37	.06	3.54	2.52	—	2.09	—	.71	2.56	2	2.9	1.6	63
-120 CV					4.72	3.70					3.74	2.2	3.6	2.4	64
-150 CV					5.91	4.88					4.92	2.5	4.5	3.7	65
-180 CV					7.09	6.06					6.10	2.8	5.4	5.5	66
-210 CV					8.27	7.24					7.24	3.4	7.2	7.5	67
-240 CV					9.45	8.43					8.43	3.6	7.8	9.6	68
-270 CV					10.63	9.61					9.65	4.2	9.1	11.3	69
-300 CV					11.81	10.79					10.79	4.7	11.2	11.8	70
-SLRA1/4- 90 CV	2	1/4	.53	.14	3.54	2.52	—	2.09	—	.71	2.52	2.2	3.5	0.8	71
-120 CV					4.72	3.70					3.74	2.6	4.4	1.2	72
-150 CV					5.91	4.88					4.92	2.8	5.3	1.9	73
-180 CV					7.09	6.06					6.06	3.1	6.4	2.9	74
-210 CV					8.27	7.24					7.24	3.2	6.8	4.9	75
-SLFA1/4- 90 CV	2	1/4	.53	.14	3.54	2.52	—	2.09	—	.71	2.52	2.2	3.5	0.8	76
-120 CV					4.72	3.70					3.74	2.6	4.4	1.2	77
-150 CV					5.91	4.88					4.92	2.8	5.3	1.9	78
-180 CV					7.09	6.06					6.06	3.1	6.4	2.9	79
-210 CV					8.27	7.24					7.24	3.2	6.8	4.9	80
F63-SLSA 8- 95-M42	1	8	11	1.5	95	42	27	15.4	25	24	78	0.7	1.9	3.4	81
-SLSB 8- 95-M42	1	8	13	2.5	95	42	27	17.4	32	24	78	0.8	2.3	2.1	82
-SLRA 8- 75-M22	1	8	14	3	75	22	27	16.3	25	24	58	0.7	1.9	1.1	83
- 95-M42					95	42		18.4			78	0.8		2	84
-SLFB 8- 75-M22	1	8	18	5	75	22	27	20.3	32	24	58	0.8	2.2	0.7	85



CODE	Fig.	φD	φC	t	L	M	L ₁	φC ₁	φC ₂	H	h		N	S		Scale model	
F63-SLSA 8- 90 CV	2	8	11	1.5	90	64	—	53	—	24	65	0.9	2.9	1.4	○	86	
-120 CV					120	94					94	1.1	3.8	2		87	
F63 -150 CV					150	124					124	1.3	5	2.7		88	
-180 CV					180	154					155	5.2	5	89			
-210 CV					210	184					184	1.5	6.6	6.6		▲	90
-240 CV					240	214					214	1.8	7.8	8.3		91	
-270 CV					270	244					244	2.1	10.7	6.9		92	
-300 CV					300	274					274	2.3	11.9	8.9		93	
-SLRA 8- 90 CV					2	8					16	4	90	64		—	53
-120 CV	120	94	95	1.2			4.6	1	95								
-150 CV	150	124	125	1.4			5.9	1.4	96								
-180 CV	180	154	155	1.6			7	2	97								
-210 CV	210	184	185	7.6			3.5	98									
-SLFA 8- 90 CV	2	8	16	4	90	64	—	53	—	24	65	1	3.4	0.7	○	99	
-120 CV					120	94					95	1.2	4.6	1		100	
-150 CV					150	124					125	1.4	5.9	1.4		101	
-180 CV					180	154					155	1.6	7	2		102	
-210 CV					210	184					185	7.6	3.5	103			
F63-SLSA5/16- 90 CV	2	5/16	.43	.06	3.54	2.52	—	2.09	—	.94	2.56	2	2.9	1.5	○	104	
-120 CV					4.72	3.70					3.70	2.2	3.8	2.0		105	
-150 CV					5.91	4.88					4.88	2.7	5.1	2.8		106	
-180 CV					7.09	6.06					6.10	2.8	5.4	5.2		107	
-210 CV					8.27	7.24					7.17	3.2	7.4	6.0		▲	108
-240 CV					9.45	8.43					8.43	3.9	8.9	6.8		109	
-270 CV					10.63	9.61					9.65	4.5	10	8.5		110	
-300 CV					11.81	10.79					10.79	5	12.3	9.0		111	
-SLRA5/16- 90 CV					2	5/16					.63	.16	3.54	2.52		—	2.09
-120 CV	4.72	3.70	3.70	2.6			4.8	1.0	113								
-150 CV	5.91	4.88	4.88	3			6.1	1.5	114								
-180 CV	7.09	6.06	6.06	3.5			7.3	2.1	115								
-210 CV	8.27	7.24	7.24	3.5			7.8	3.6	116								
-SLFA5/16- 90 CV	2	5/16	.63	.16	3.54	2.52	—	2.09	—	.94	2.52	2.2	3.5	0.7	○	117	
-120 CV					4.72	3.70					3.70	2.6	4.8	1.0		118	
-150 CV					5.91	4.88					4.88	3	6.1	1.5		119	
-180 CV					7.09	6.06					6.06	3.5	7.3	2.1		120	
-210 CV					8.27	7.24					7.24	3.5	7.8	3.6		121	
F63-SLSA10- 95-M42	1	10	13	1.5	95	42	27	17.4	25	30	74	0.8	2	2.6	○	122	
-SLSB10- 95-M42	1	10	16	3	95	42	27	20.4	32	30	74	0.8	2.3	1.4	○	123	
-SLRA10- 75-M22	1	10	16	3	75	22	27	18.3	25	30	54	0.8	1.9	1	○	124	
-SLFB10- 75-M22	1	10	22	6	75	22	27	24.3	32	30	54	0.8	2.3	0.6	×	125	
-SLSA10- 90 CV	2	10	13	1.5	90	64	—	53	—	30	65	0.9	2.9	1.3	○	126	
-120 CV					120	94					95	1.2	4.4	127			
-150 CV					150	124					125	1.3	5.2	2.2		128	
-180 CV					180	154					154	1.5	6.3	3.4		129	
-210 CV					210	184					184	1.6	6.8	6		130	
-240 CV					240	214					212	2	9.4	5.8		▲	131
-270 CV					270	244					244	2.1	10.9	6.6		132	
-300 CV					300	274					274	2.3	12.2	8.5		133	



Feature
Shrink-fit Heater
MONO 3° MONO CURVE
MONO Series
2PIECE type
UNO
HYPER version
STRAIGHT arbor
OTHERS
PERIPHERALS
Technical data

CODE	Fig.	φD	φC	t	L	M	L ₁	φC ₁	φC ₂	H	h	Kg lbs	N	S	Scale model
F63-SLRA10- 90 CV	2	10	19	4.5	90	64	—	53	—	30	65	1	3.5	0.6	134
-120 CV					120	94					95	1.2	4.6	0.9	135
-150 CV					150	124					125	1.4	5.8	1.4	136
-180 CV					180	154					155	1.6	7.2	2	137
-210 CV					210	184					185		8	3.1	138
-SLFA10- 90 CV	2	10	19	4.5	90	64	—	53	—	30	65	1	3.5	0.6	139
-120 CV					120	94					95	1.2	4.6	0.9	140
-150 CV					150	124					125	1.4	5.8	1.4	141
-180 CV					180	154					155	1.6	7.2	2	142
-210 CV					210	184					185		8	3.1	143
F63-SLSA3/8- 90 CV	3	3/8	.49	.06	3.54	2.52	—	2.09	—	1.18	2.56	2	2.9	1.3	144
-120 CV					4.72	3.70					3.74	2.3	3.8	2.2	145
F63 -150 CV					5.91	4.88					4.88	2.6	5.2	2.6	146
-180 CV					7.09	6.06					6.06	3.1	6.4	3.6	147
-210 CV					8.27	7.24					7.24	3.5	7.8	4.9	148
-240 CV					9.45	8.43					8.46	4.1	9	6.0	149
-270 CV					10.63	9.61					9.61	4.6	11.2	6.8	150
-300 CV					11.81	10.79					10.79	5	12.5	8.8	151
-SLRA3/8- 90 CV	3	3/8	.73	.185	3.54	2.52	—	2.09	—	1.18	2.52	2.2	3.5	0.7	152
-120 CV					4.72	3.70					3.70	2.6	4.8	1.0	153
-150 CV					5.91	4.88					4.88	3	6.1	1.4	154
-180 CV					7.09	6.06					6.06	3.4	7.4	2.0	155
-210 CV					8.27	7.24					7.28	3.9	8.3	2.9	156
-SLFA3/8- 90 CV	3	3/8	.73	.185	3.54	2.52	—	2.09	—	1.18	2.52	2.2	3.5	0.7	157
-120 CV					4.72	3.70					3.70	2.6	4.8	1.0	158
-150 CV					5.91	4.88					4.88	3	6.1	1.4	159
-180 CV					7.09	6.06					6.06	3.4	7.4	2.0	160
-210 CV					8.27	7.24					7.28	3.9	8.3	2.9	161
F63-SLSA12- 95-M42	1	12	15	1.5	95	42	27	19.4	32	30	74	0.8	2.3	1.8	162
-SLSB12- 95-M42	1	12	19	3.5	95	42	27	23.4	32	30	74	0.8	2.4	1.1	163
-SLRA12- 75-M22	1	12	20	4	75	22	27	22.3	25	30	54	0.9	2.1	0.8	164
-SLFB12- 75-M22	1	12	26	7	75	22	27	28.3	42	30	54	0.9	3	0.4	165
-SLSA12- 90 CV	2	12	15	1.5	90	64	—	53	—	30	64	1	3.4	0.9	166
-120 CV					120	94					94	1.2	4.7	1.2	167
-150 CV					150	124					124	1.3	5.2	2.4	168
-180 CV					180	154					154	1.5	6.5	3.3	169
-210 CV					210	184					184	1.7	7.7	4.6	170
-240 CV					240	214					212	2	9.6	5.5	171
-270 CV					270	244					244	2.2	11.8	5.4	172
-SLRA12- 90 CV	2	12	22	5	90	64	—	53	—	30	64	1	3.6	0.6	173
-120 CV					120	94					94	1.3	5.5	0.7	174
-150 CV					150	124					124	1.5	6.7	1.1	175
-180 CV					180	154					154	1.6	7.5	1.8	176
-210 CV					210	184					184	1.7	8.5	2.8	177
-SLFA12- 90 CV	2	12	22	5	90	64	—	53	—	30	64	1	3.6	0.6	178
-120 CV					120	94					94	1.3	5.5	0.7	179
-150 CV					150	124					124	1.5	6.7	1.1	180
-180 CV					180	154					154	1.6	7.5	1.8	181
-210 CV					210	184					184	1.7	8.5	2.8	182



CODE	Fig.	φD	φC	t	L	M	L ₁	φC ₁	φC ₂	H	h	Kg lbs	N	S	Scale model
F63-SLSA1/2- 90 CV	3	1/2	.62	.06	3.54	2.52	—	2.09	—	1.18	2.52	2.1	3.6	0.8	183
-120 CV					4.72	3.70					3.70	2.5	4.9	1.2	184
F63 -150 CV					5.91	4.88					4.88	2.6	5.3	2.4	185
-180 CV					7.09	6.06					6.06	3	6.7	3.4	186
-210 CV					8.27	7.24					7.17	3.6	9.3	3.6	187
-240 CV					9.45	8.43					8.35	4.1	11.5	4.3	188
-270 CV					10.63	9.61					9.53	4.7	13.3	5.1	189
-SLRA1/2- 90 CV					3	1/2					.89	.20	3.54	2.52	—
-120 CV	4.72	3.70	3.70	2.9			5.7	0.7	191						
-150 CV	5.91	4.88	4.88	3.3			7	1.1	192						
-180 CV	7.09	6.06	5.98	3.3			8.3	1.9	193						
-210 CV	8.27	7.24	7.24	4.4			10.4	2.0	194						
-SLFA1/2- 90 CV	3	1/2	.89	.20	3.54	2.52	—	2.09	—	1.18	2.44	2.2	4	0.5	195
-120 CV					4.72	3.70					3.70	2.9	5.7	0.7	196
-150 CV					5.91	4.88					4.88	3.3	7	1.1	197
-180 CV					7.09	6.06					5.98	3.3	8.3	1.9	198
-210 CV					8.27	7.24					7.24	4.4	10.4	2.0	199
F63-SLFB16- 75-M22	1	16	32	8	75	22	27	34.3	42	32	54	1	3.1	0.3	200
-SLSB16- 90 CV	2	16	21	2.5	90	64	—	53	—	32	62	1.1	3.9	0.6	201
-120 CV					120	94					92	1.4	5.8	0.8	202
-150 CV					150	124					122	1.5	6.9	1.5	203
-180 CV					180	154					152	1.9	8.8	1.9	204
-210 CV					210	184					182	2	9.9	3	205
-240 CV					240	214					212	2.3	11.8	3.7	206
-270 CV					270	244					242	2.7	13.7	4.6	207
F63-SLSB5/8- 90 CV					3	5/8					.82	.10	3.54	2.52	—
-120 CV	4.72	3.70	3.62	2.7			5.9	0.8	209						
-150 CV	5.91	4.88	4.80	2.9			7	1.5	210						
-180 CV	7.09	6.06	5.98	3.5			9	1.9	211						
-210 CV	8.27	7.24	7.17	3.7			10.1	3.0	212						
-240 CV	9.45	8.43	8.35	4.3			12.1	3.7	213						
-270 CV	10.63	9.61	9.53	4.8			14.1	4.6	214						
F63-SLFB20- 75-M22*	1	20	38	9			75	22	27	40.3			50	40	
-SLSB20- 90 CV	2	20	26	3	90	64	—	51	—	40	62	1.1	4.2	0.5	216
-120 CV					120	94		53			92	1.4	6.2	0.8	217
-150 CV					150	124		122			1.6	7.6	1.3	218	
-180 CV					180	154		152			2	9.6	1.8	219	
-210 CV					210	184		182			2.3	11.6	2.3	220	
-240 CV					240	214		212			2.6	13.7	3	221	
-270 CV					270	244		242			3.1	16.3	3.4	222	
F63-SLSB3/4- 90 CV					3	3/4		.99			.12	3.54	2.52	—	2.09
-120 CV	4.72	3.70	3.62	2.7			6.3		0.8	224					
-150 CV	5.91	4.88	4.80	2.9			7.6		1.4	225					
-180 CV	7.09	6.06	5.98	3.5			9.7		1.8	226					
-210 CV	8.27	7.24	7.17	4			11.8		2.4	227					
-240 CV	9.45	8.43	8.35	4.5			14		3.1	228					
-270 CV	10.63	9.61	9.53	5.1			16.1		3.9	229					
F63-SLFB25- 75-M22	1	25	45	10			75		22	27		47.3	50		



※ When shrinking the SLFB20 with HEAT ROBO DENJI 5000(HRD-02S), the standard heating coil cannot be used. Please use the heating coil No.4.

■ Cleaning tool for a spindle taper hole, STAR DUST

CODE
CLT-F63-G2

● P.226



DMG MORI NVD4000 DCG
NV4000 DCG
MAKINO V33i / V56i



Feature

Shrink-fit Heater

MONO 3°
MONO CURVE

MONO Series

2PIECE type

UNO

HYPER
version

STRAIGHT
arbor

OTHERS

PERIPHERALS

Technical
data

φ 3

F63-SLSA3-75-M37

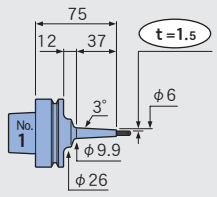

8.0

F63-SLSA3-95-M42

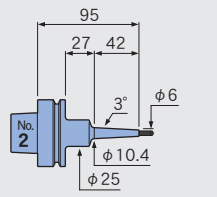

9.1

F63-SLRA3-70-M22

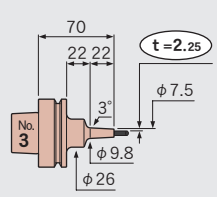

2.8

F63-SLRA3-75-M22

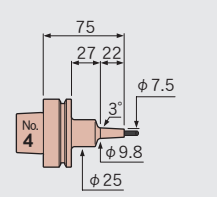

2.8

F63-SLRA3-95-M42

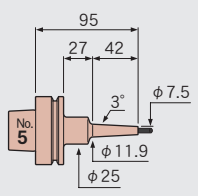

5.3

F63-SLFB3-75-M22

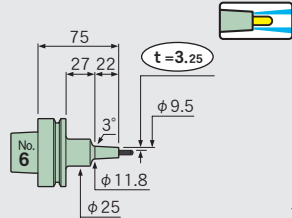

1.9

F63-SLFB3-95-M42

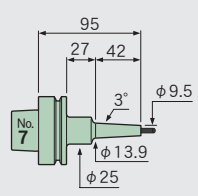

3.2

F63-SLFB3-120-M67

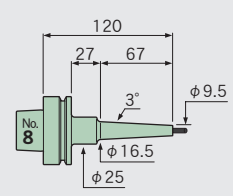

5.4

φ 4

F63-SLSA4-95-M42

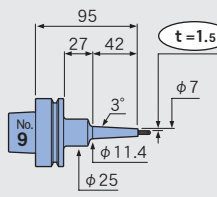

7.2

F63-SLRA4-75-M22

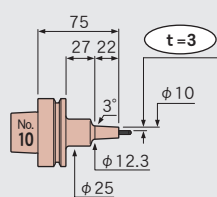

1.7

F63-SLRA4-95-M42

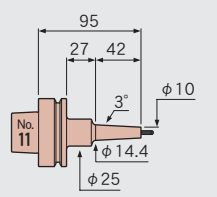

3.1

F63-SLFB4-75-M22

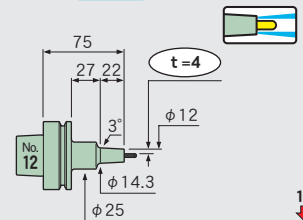

1.3

F63-SLFB4-95-M42

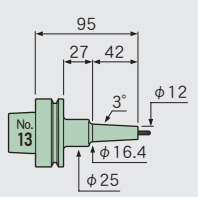

2.2

F63-SLFB4-120-M67

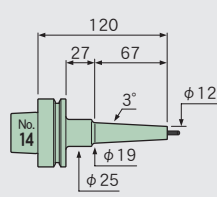

3.6

F63-SLSA4-90 CV

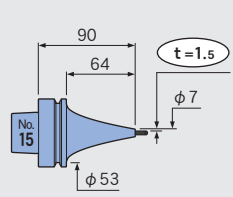

1.8

F63-SLSA4-120 CV

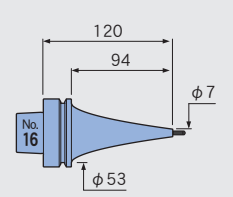

2.7

F63-SLSA4-150 CV

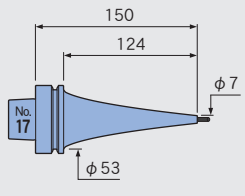

4.0

F63-SLSA4-180 CV

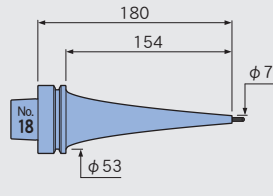

6.6

F63-SLSA4-210 CV

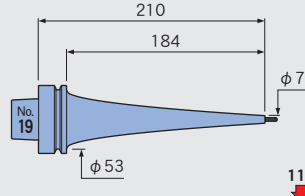

11.6

F63-SLSA4-240 CV

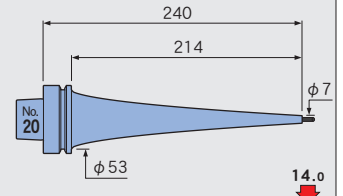

14.0

F63-SLSA4-270 CV

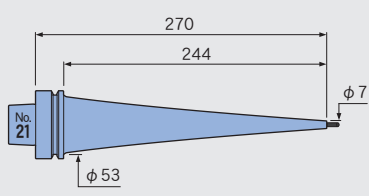

11.9

F63-SLSA4-300 CV

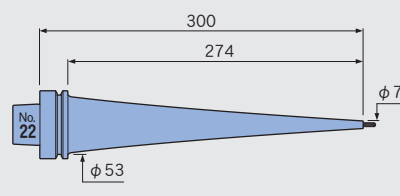

15.9

F63-SLRA4-120 CV

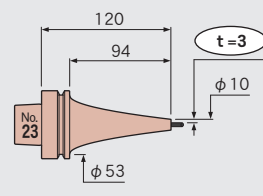

1.9

Feature
Shrink-fit Heater
MONO 3° MONO CURVE
MONO Series
2PIECE type
UNO
HYPER version
STRAIGHT anbor
OTHERS
PERIPHERALS
Technical data

F63-SLRA4-150 CV

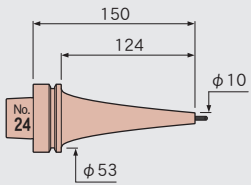

2.9

F63-SLRA4-180 CV

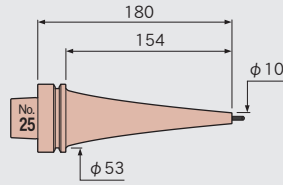

3.3

F63-SLRA4-210 CV

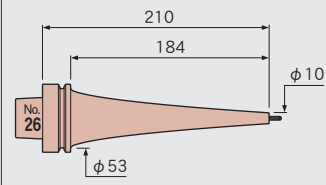

5.6

φ 3/16

F63-SLSA3/16-90 CV

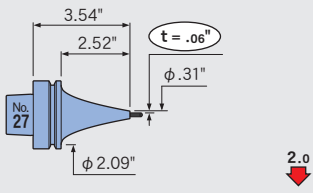

2.0

F63-SLSA3/16-120 CV

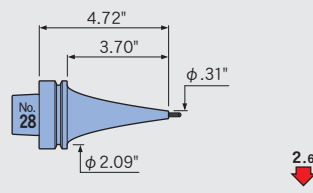

2.6

F63-SLSA3/16-150 CV

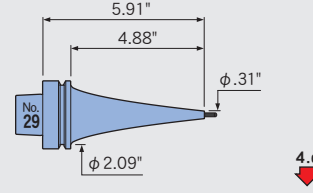

4.0

F63-SLSA3/16-180 CV

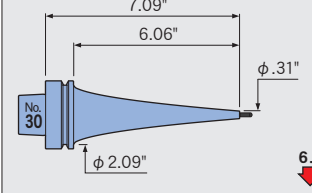

6.5

F63-SLSA3/16-210 CV

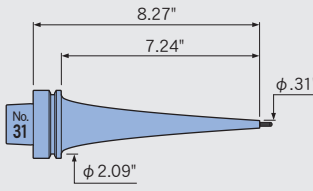

8.4

F63-SLSA3/16-240 CV

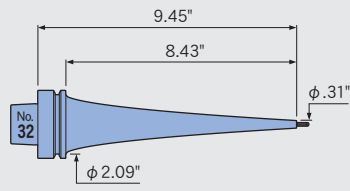

10.6

F63-SLSA3/16-270 CV

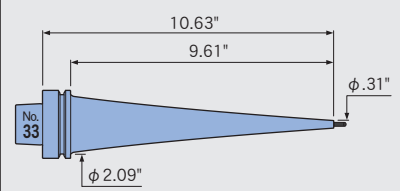

13.2

F63-SLSA3/16-300 CV

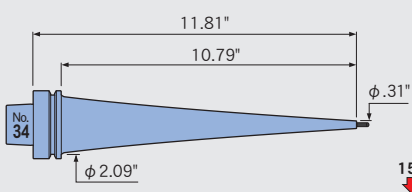

15.9

F63-SLRA3/16-120 CV

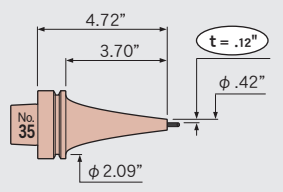

1.8

F63-SLRA3/16-150 CV

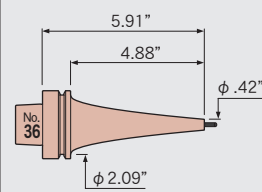

2.4

F63-SLRA3/16-180 CV

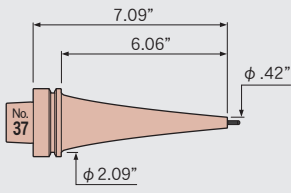

4.3

F63-SLRA3/16-210 CV

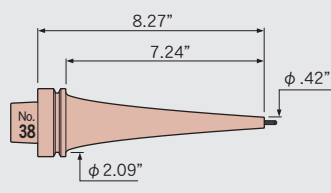

5.7

φ 6

F63-SLSA6-95-M42

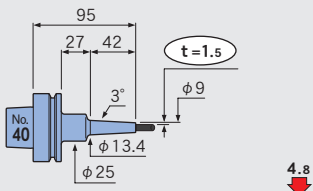

4.8

F63-SLSB6-95-M42

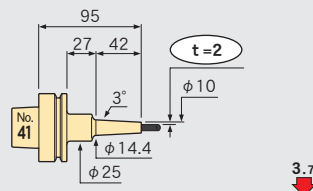

3.7

F63-SLRA6-75-M22

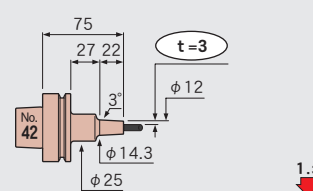

1.3

F63-SLRA6-95-M42

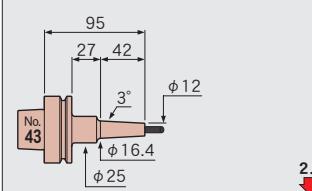

2.4

Feature
Shrink-fit Heater
MONO 3° MONO CURVE
MONO Series
2PIECE type
UNO
HYPER version
STRAIGHT arbor
OTHERS
PERIPHERALS
Technical data

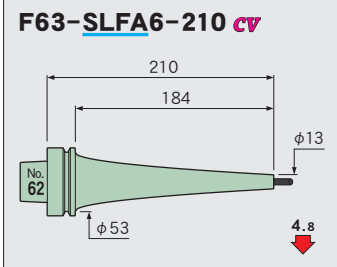
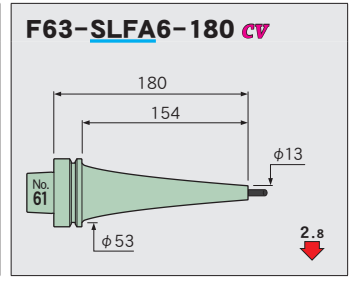
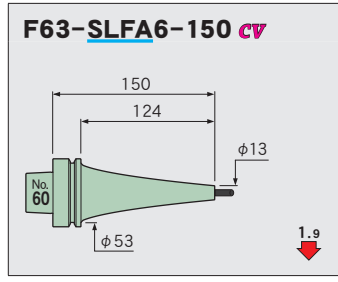
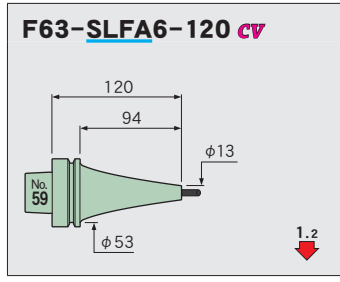
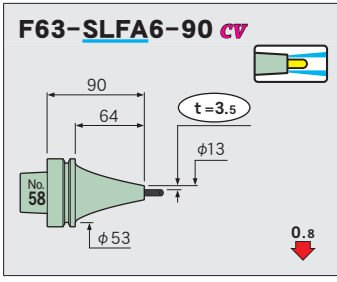
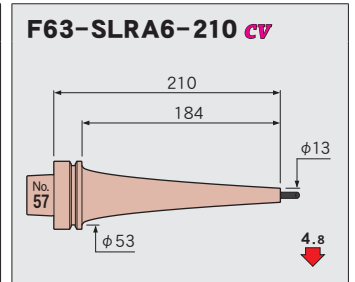
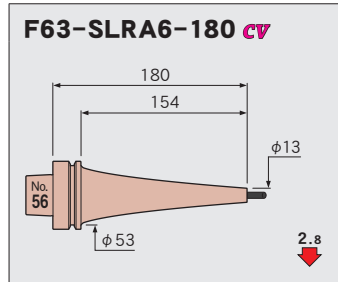
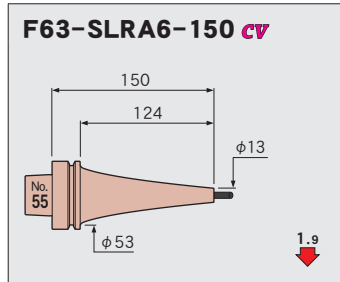
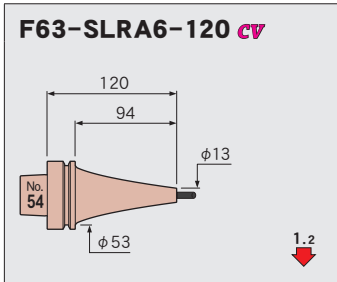
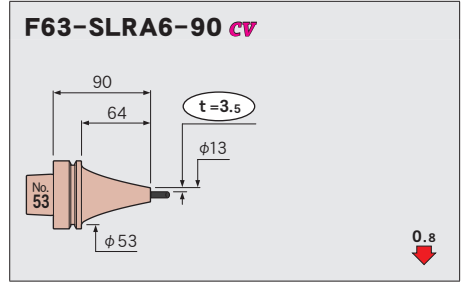
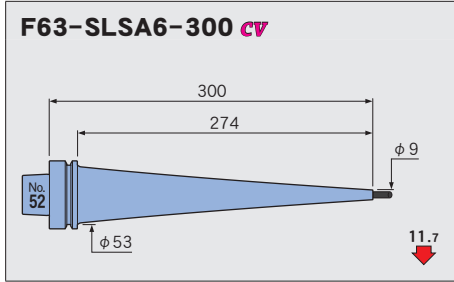
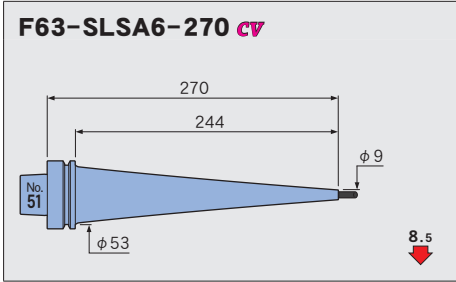
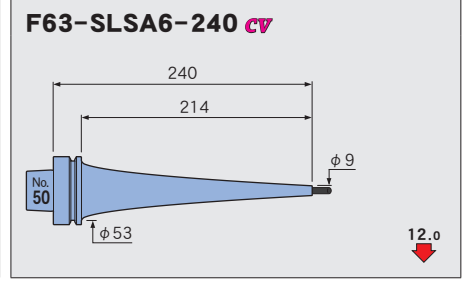
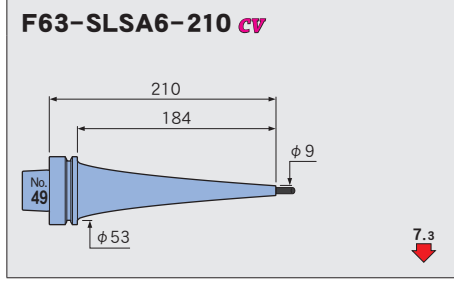
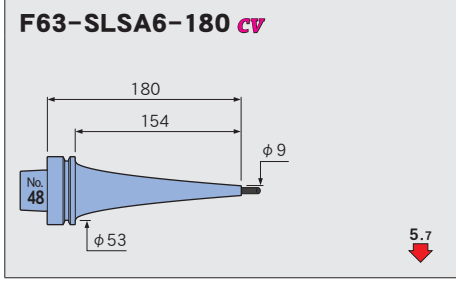
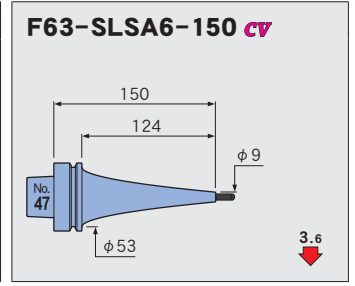
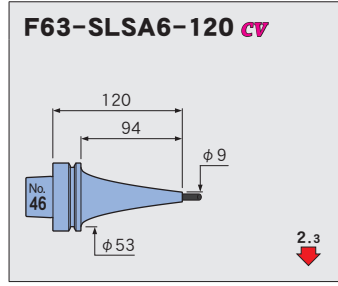
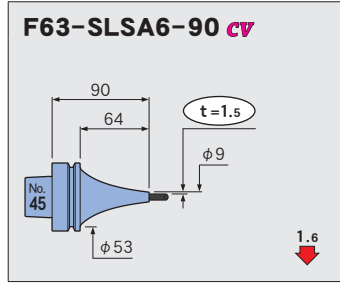
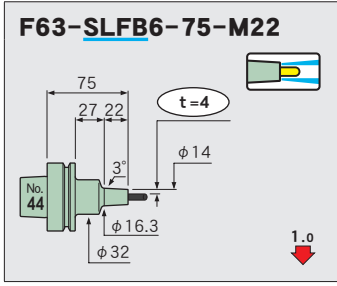

$\phi 1/4$

F63-SLSA1/4-90 CV

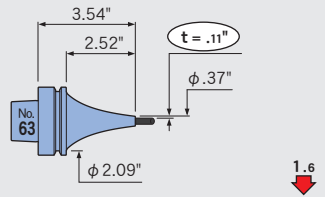

F63-SLSA1/4-120 CV

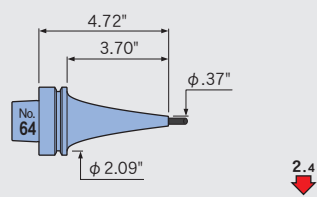

F63-SLSA1/4-150 CV

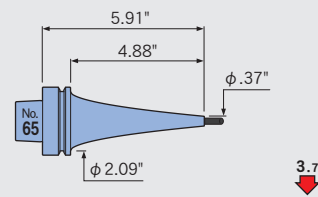

F63-SLSA1/4-180 CV

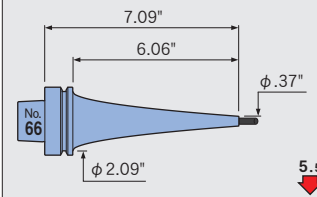

F63-SLSA1/4-210 CV

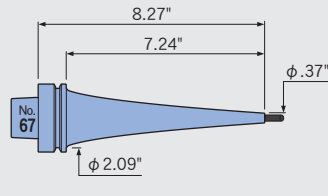

F63-SLSA1/4-240 CV

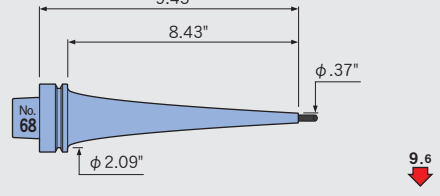

F63-SLSA1/4-270 CV

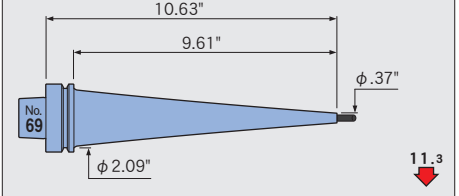

F63-SLSA1/4-300 CV

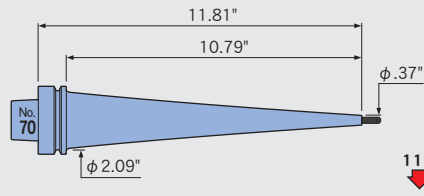

F63-SLRA1/4-90 CV

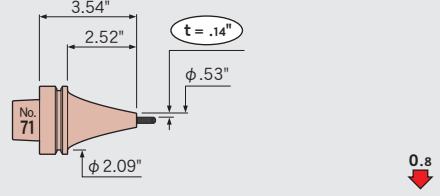

F63-SLRA1/4-120 CV

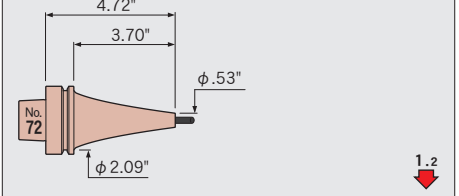

F63-SLRA1/4-150 CV

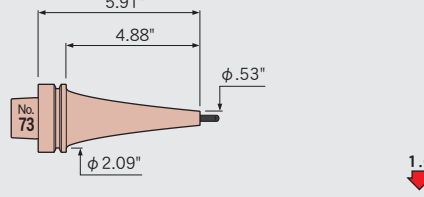

F63-SLRA1/4-180 CV

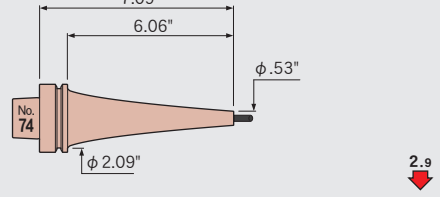

F63-SLRA1/4-210 CV

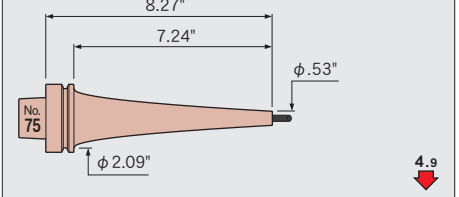

F63-SLFA1/4-90 CV

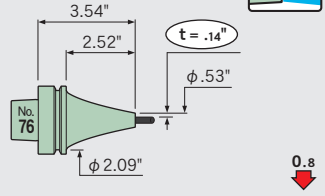

F63-SLFA1/4-120 CV

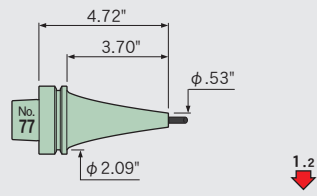

F63-SLFA1/4-150 CV

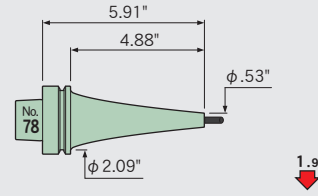

F63-SLFA1/4-180 CV

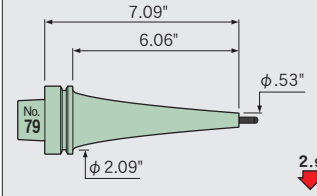

F63-SLFA1/4-210 CV

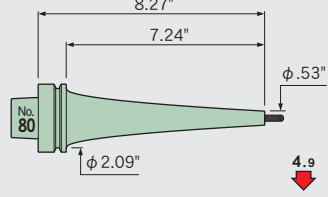

Feature
Shrink-fit Heater

MONO 3°
MONO CURVE

MONO Series

2PIECE type

UNO

HYPER
version

STRAIGHT
arbor

OTHERS

PERIPHERALS

Technical
data

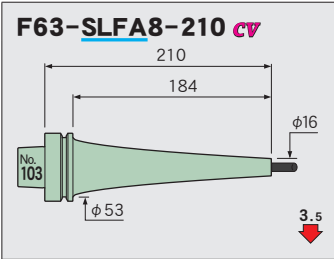
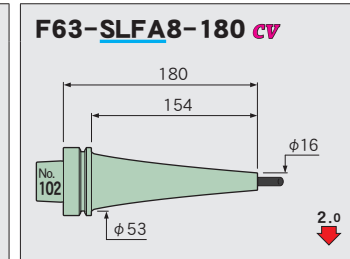
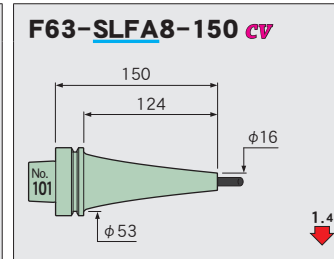
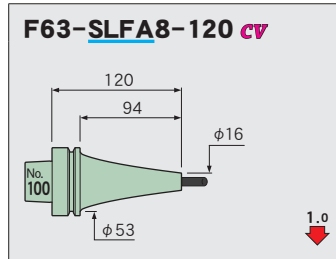
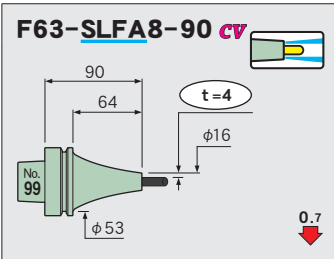
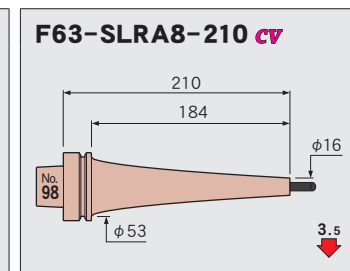
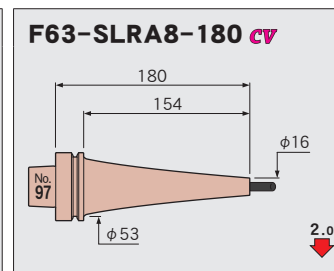
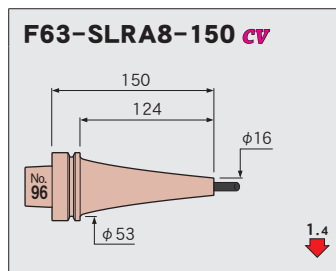
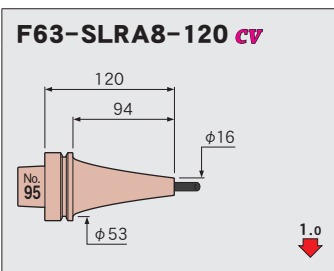
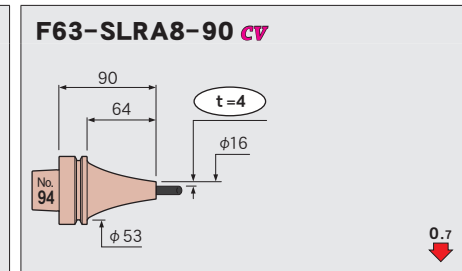
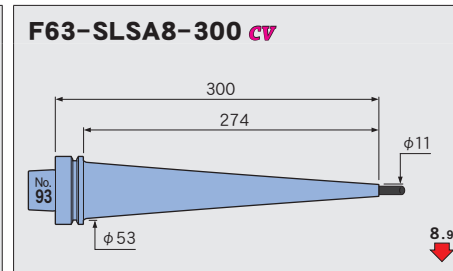
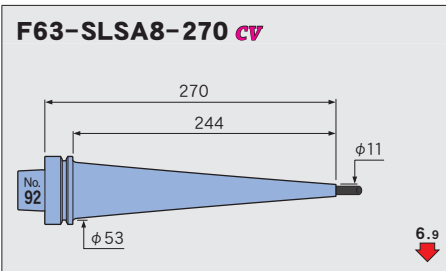
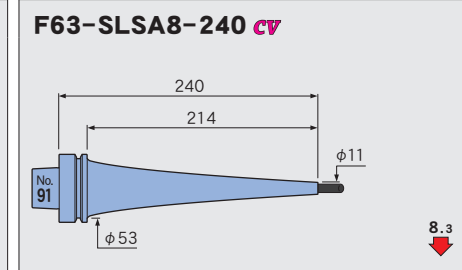
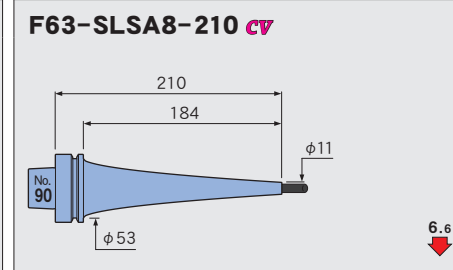
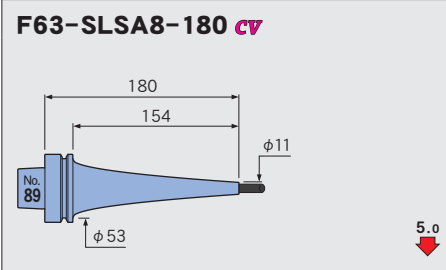
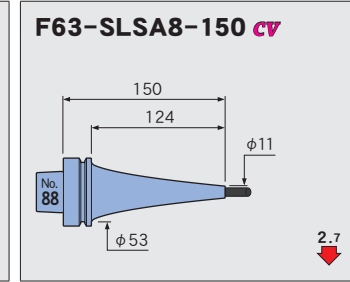
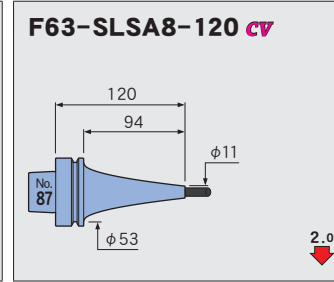
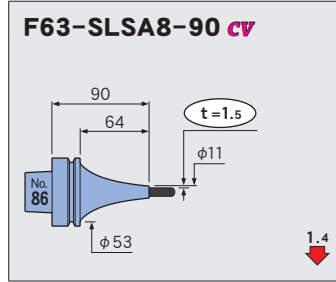
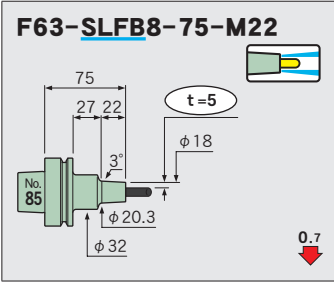
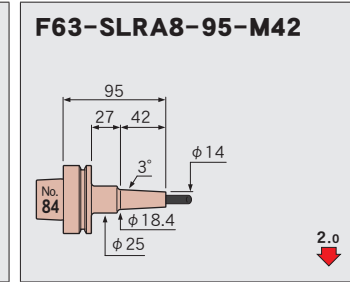
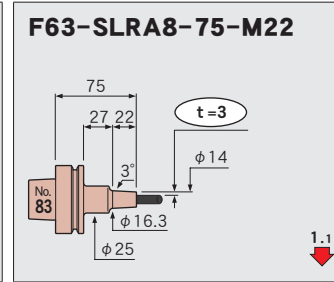
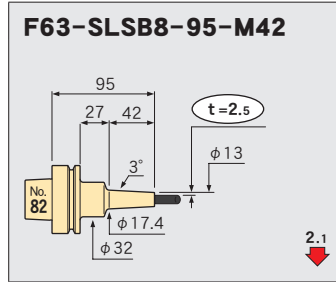
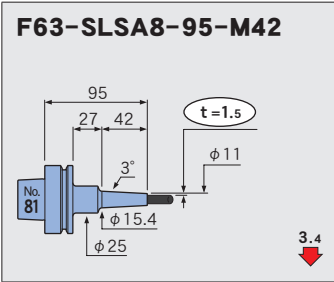

$\phi 5/16$

F63-SLSA5/16-90 CV

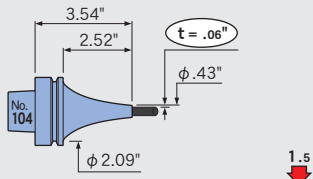

F63-SLSA5/16-120 CV

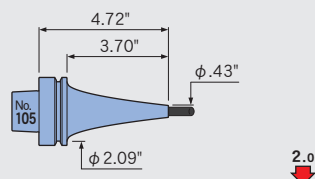

F63-SLSA5/16-150 CV

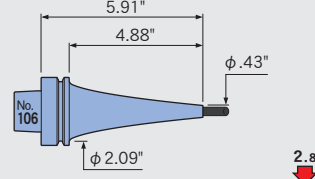

F63-SLSA5/16-180 CV

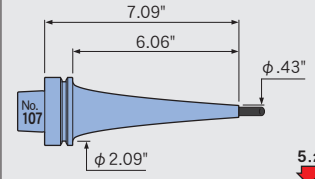

F63-SLSA5/16-210 CV

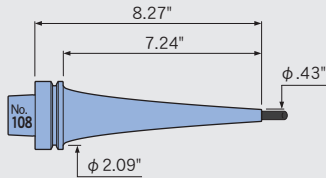

F63-SLSA5/16-240 CV

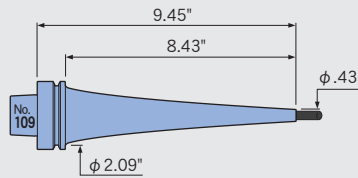

F63-SLSA5/16-270 CV

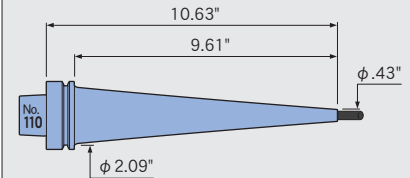

F63-SLSA5/16-300 CV

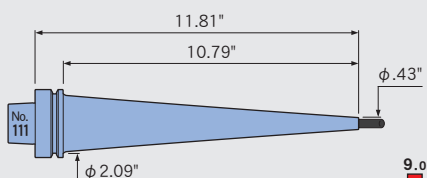

F63-SLRA5/16-90 CV

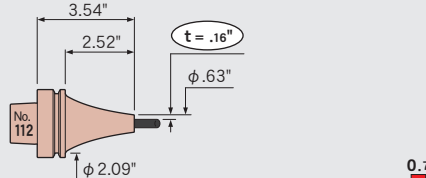

F63-SLRA5/16-120 CV

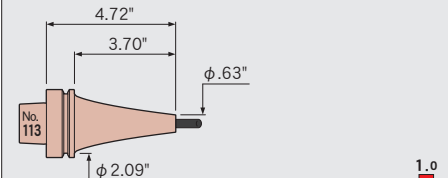

F63-SLRA5/16-150 CV

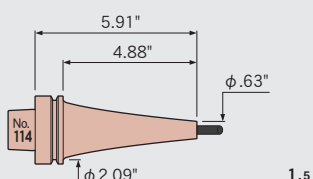

F63-SLRA5/16-180 CV

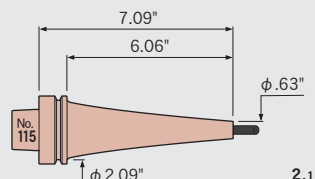

F63-SLRA5/16-210 CV

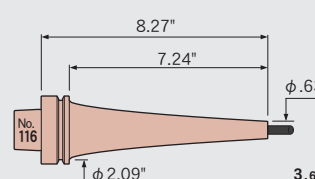

F63-SLFA5/16-90 CV

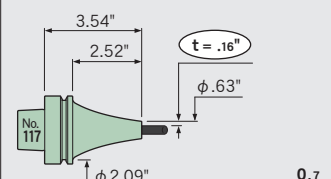

F63-SLFA5/16-120 CV

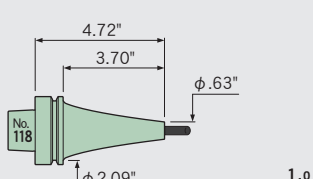

F63-SLFA5/16-150 CV

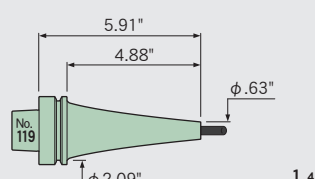

F63-SLFA5/16-180 CV

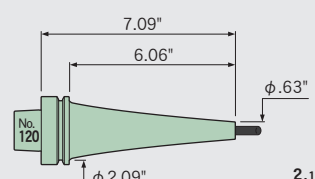

F63-SLFA5/16-210 CV

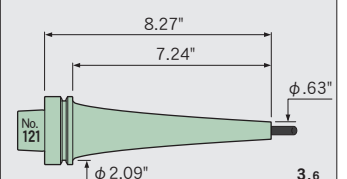

Feature

Shrink-fit Heater

MONO 3°
MONO CURVE

MONO Series

2PIECE type

UNO

HYPER
version

STRAIGHT
arbor

OTHERS

PERIPHERALS

Technical
data

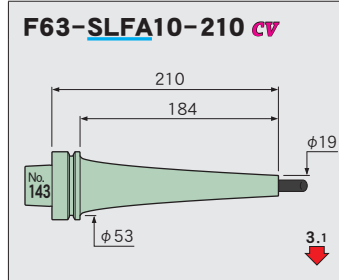
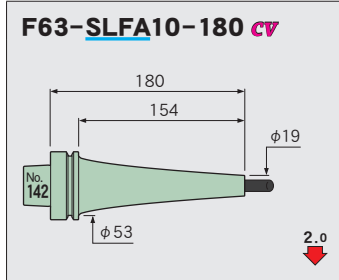
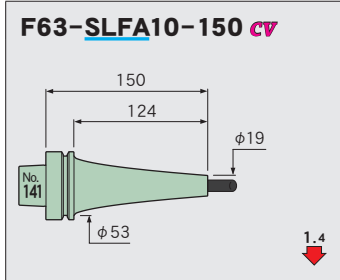
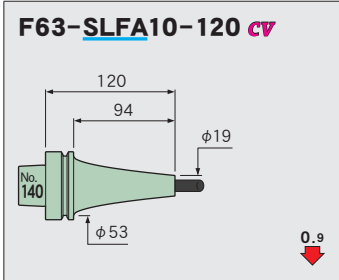
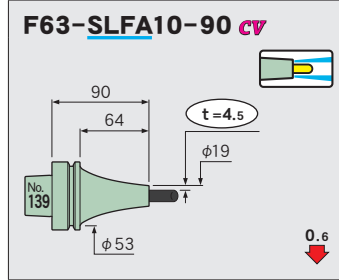
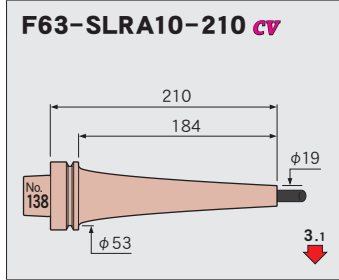
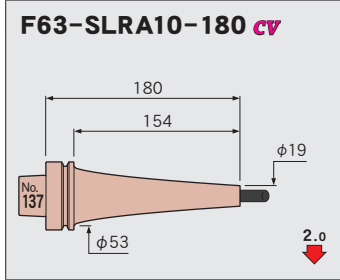
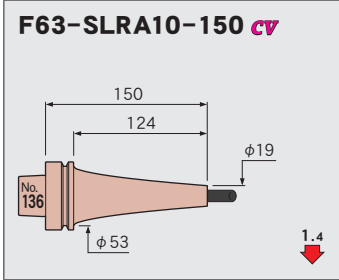
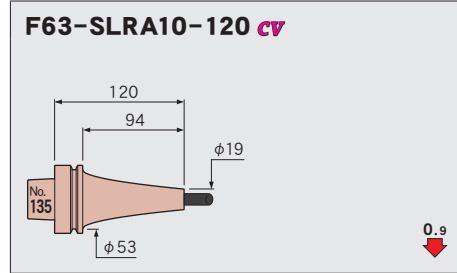
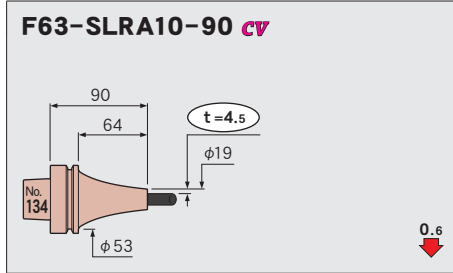
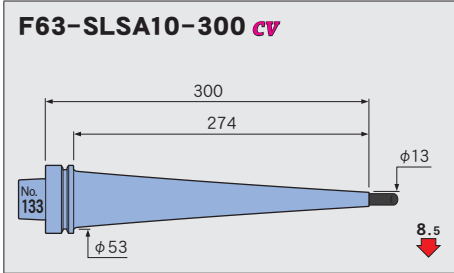
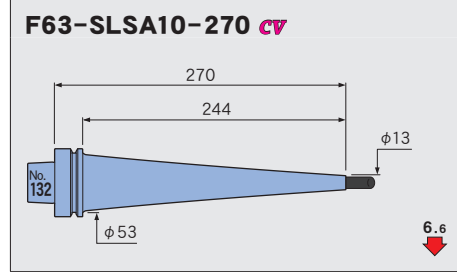
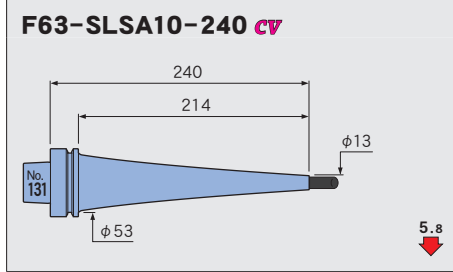
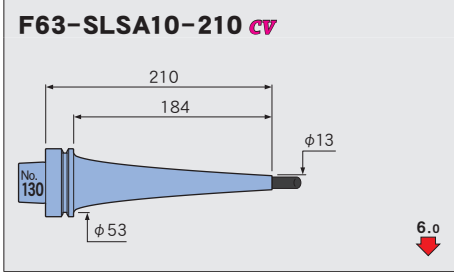
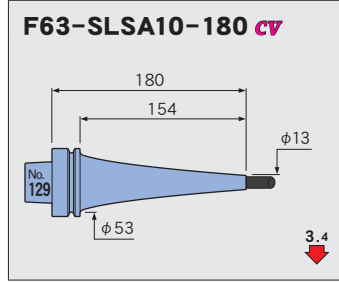
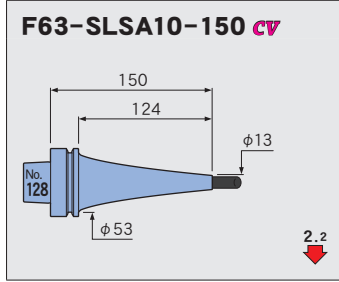
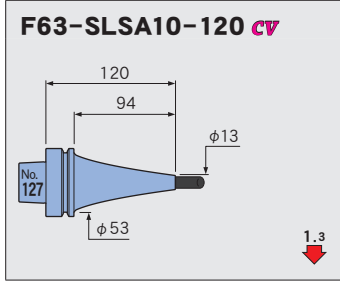
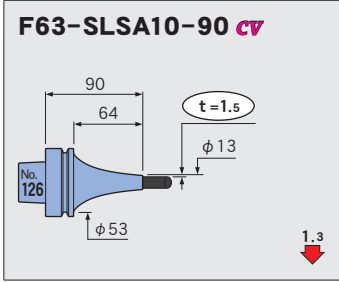
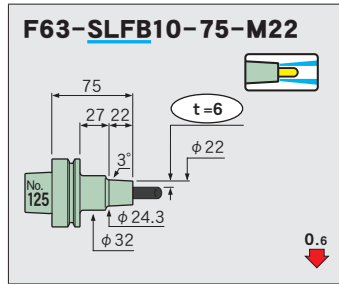
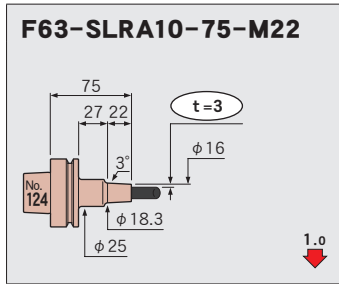
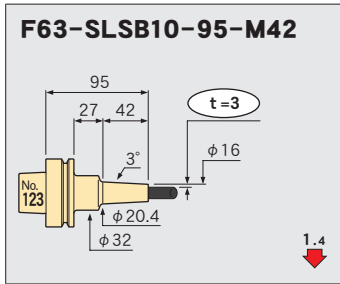
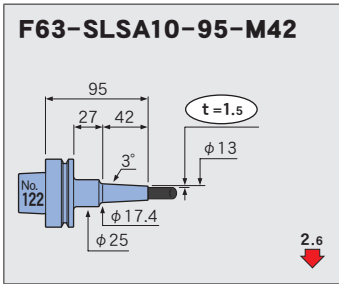

$\phi 3/8$

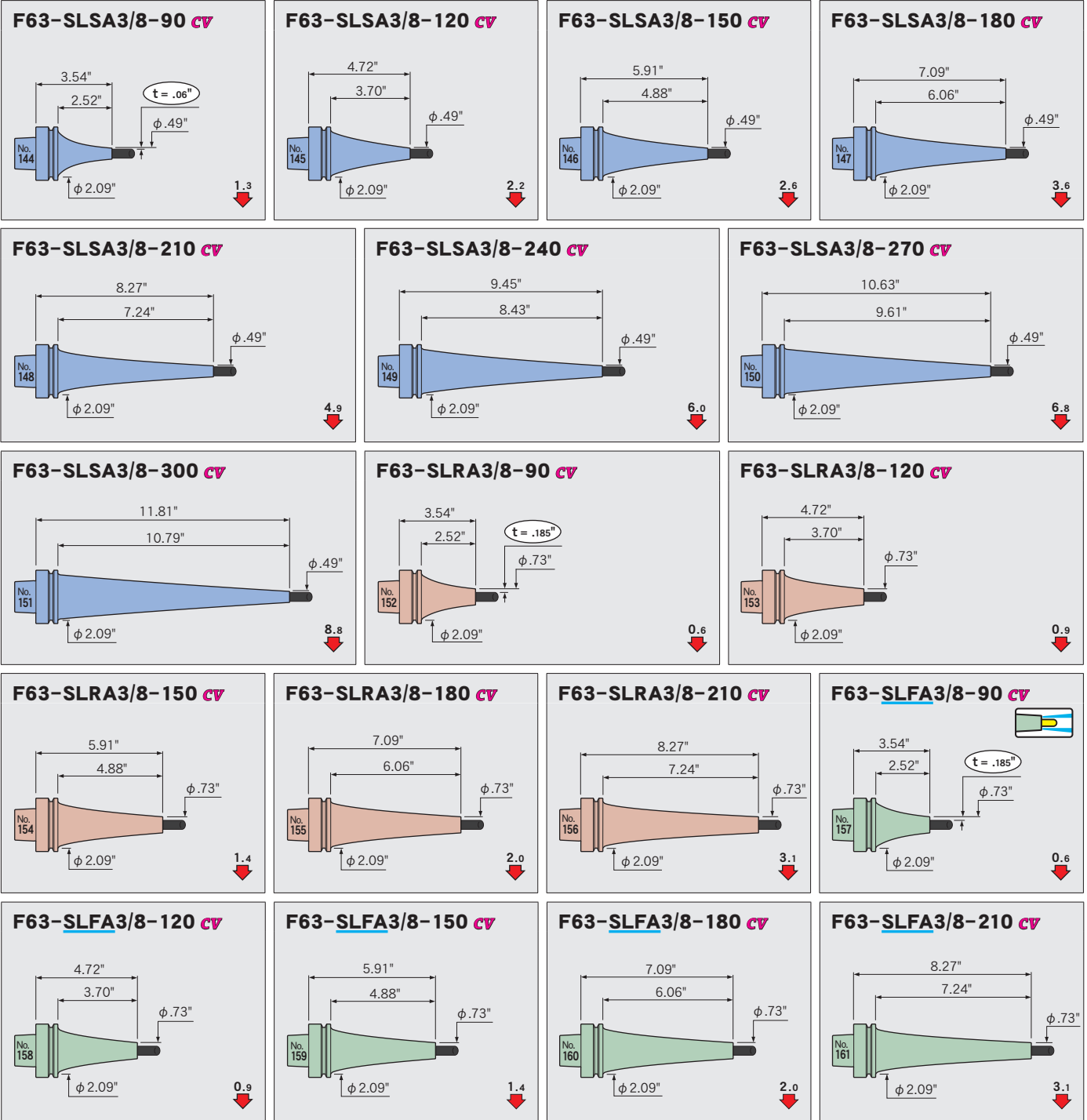

Feature

Shrink-fit Heater

MONO 3°
MONO CURVE

MONO Series

2PIECE type

UNO

HYPER
version

STRAIGHT
arbor

OTHERS

PERIPHERALS

Technical
data

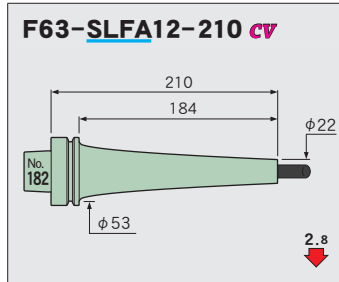
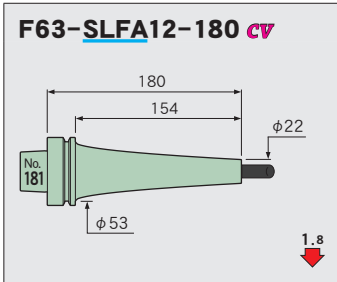
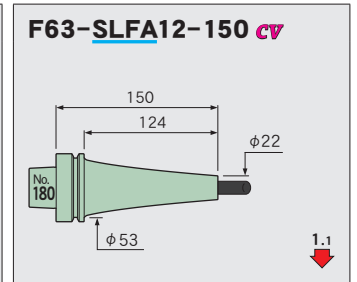
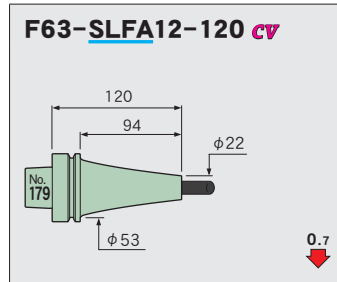
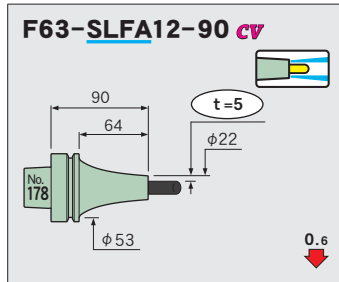
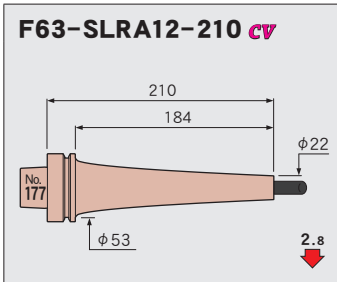
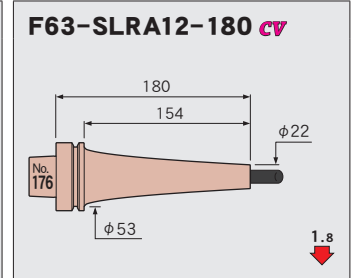
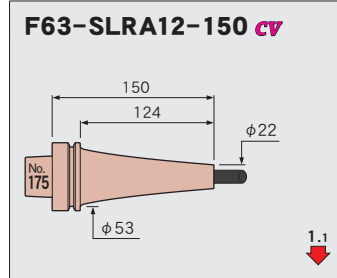
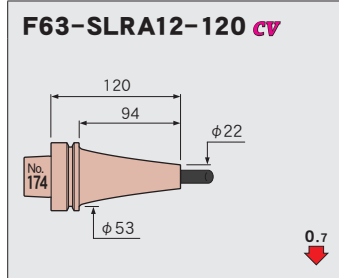
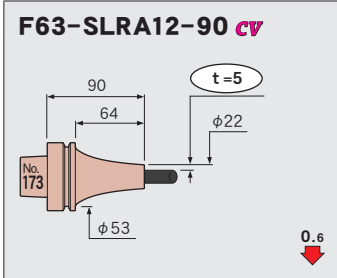
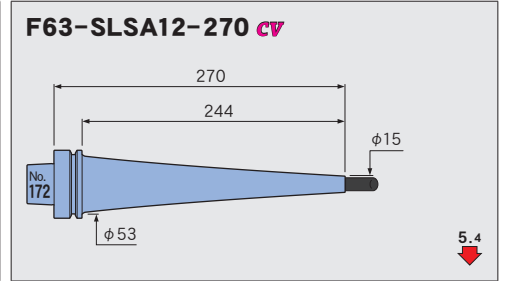
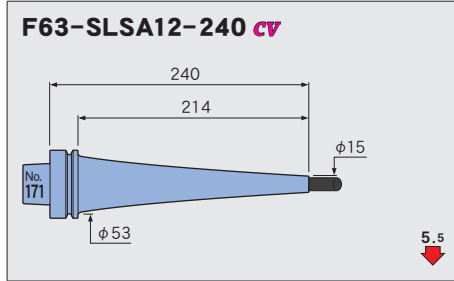
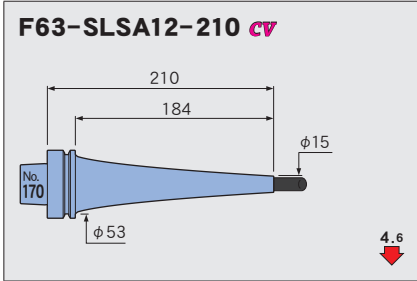
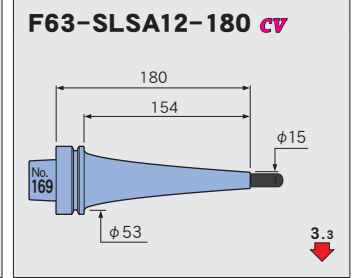
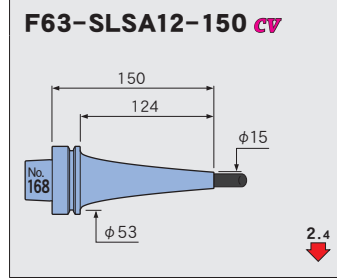
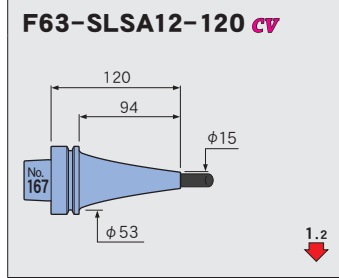
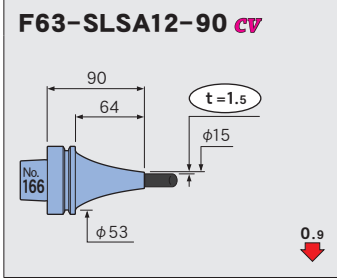
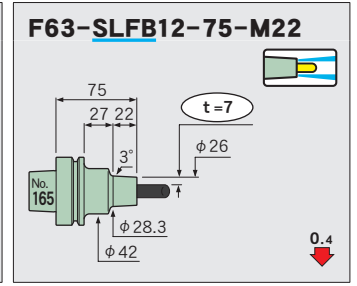
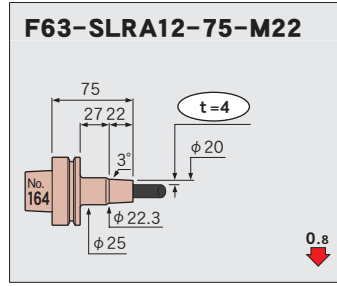
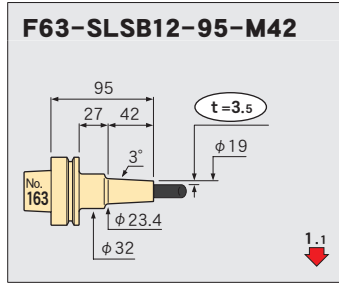
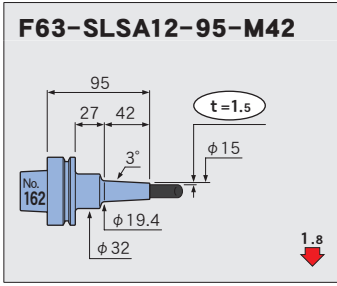

$\phi 1/2$

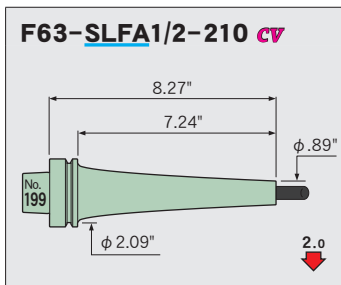
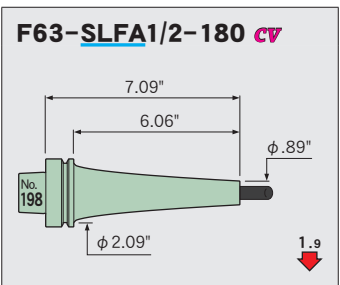
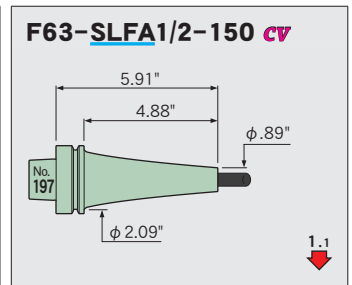
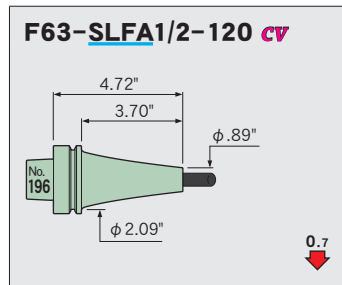
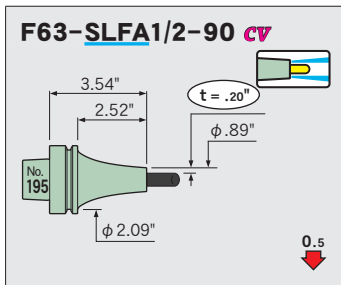
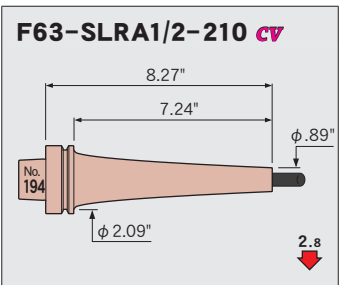
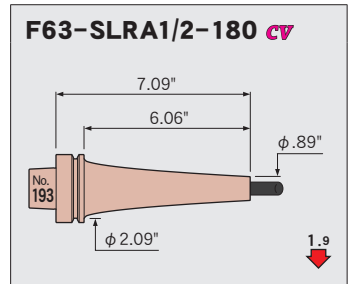
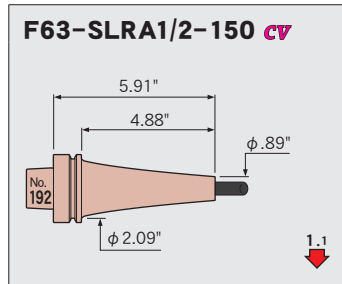
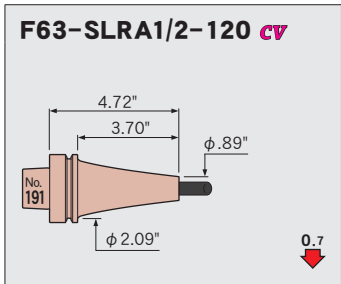
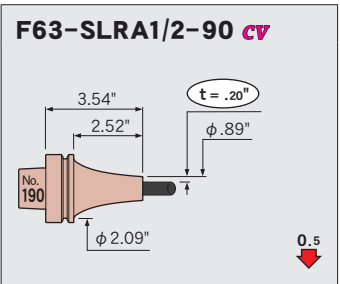
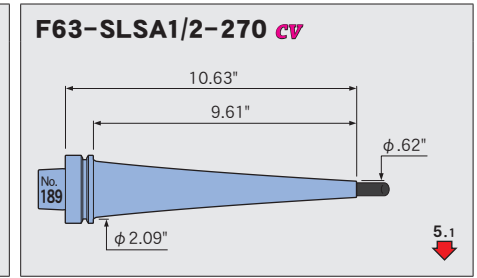
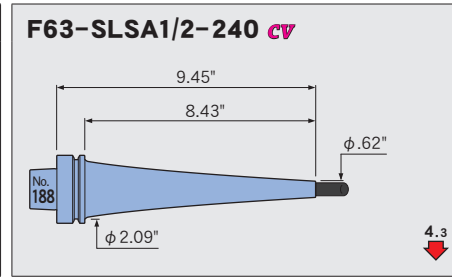
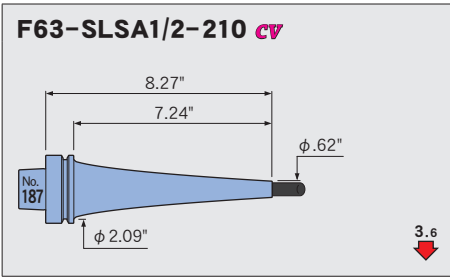
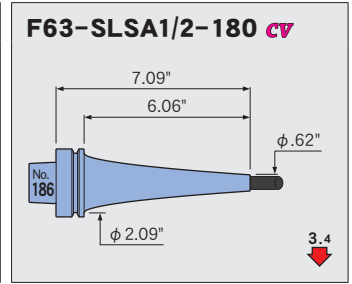
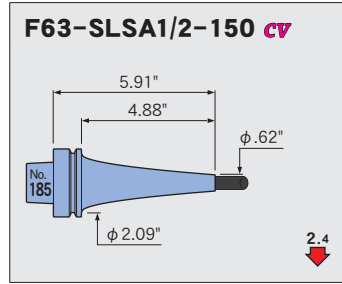
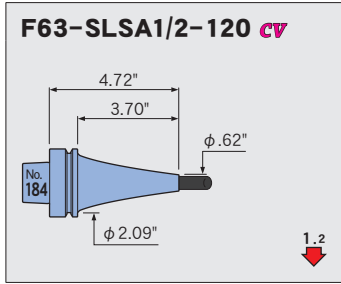
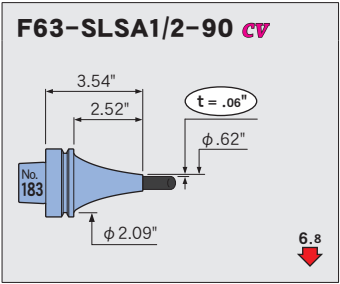

$\phi 16$

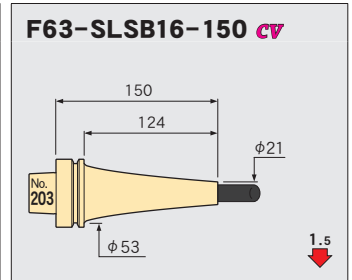
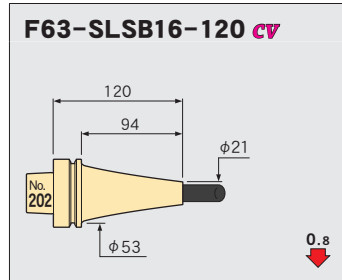
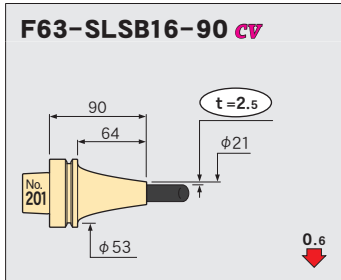
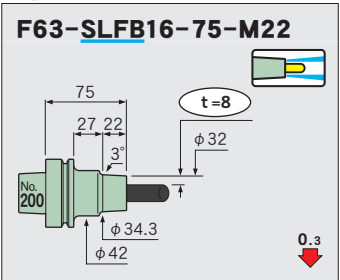

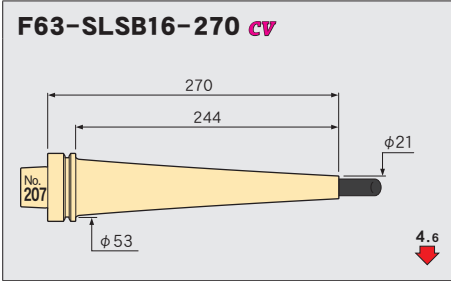
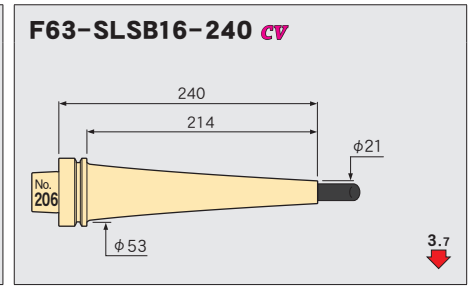
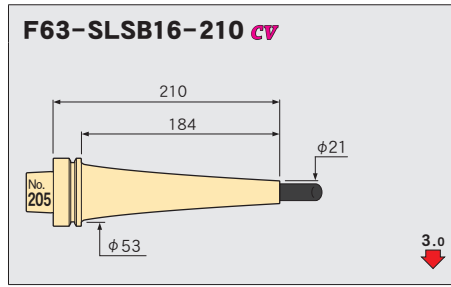
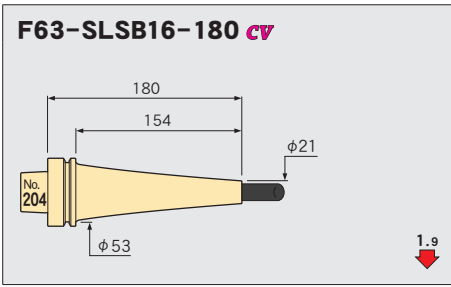

φ 5/8

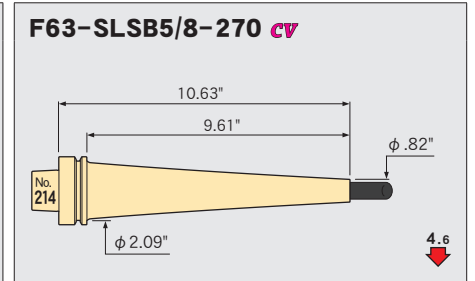
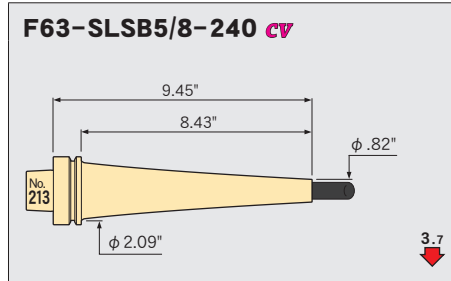
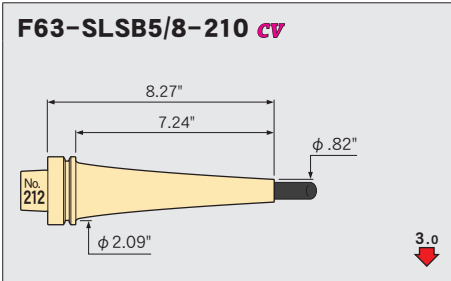
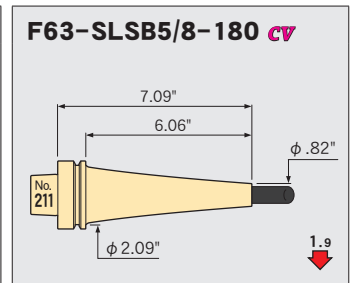
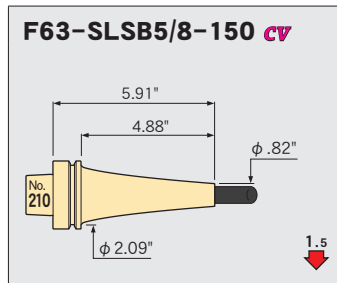
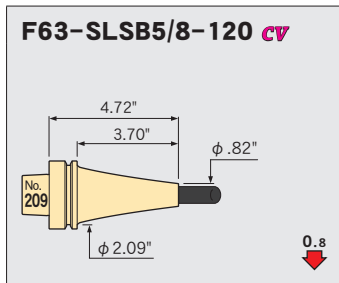
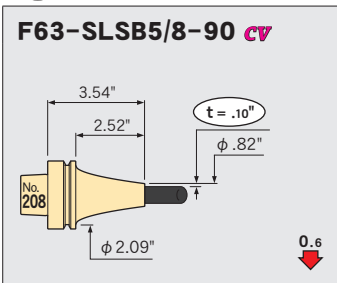

φ 20

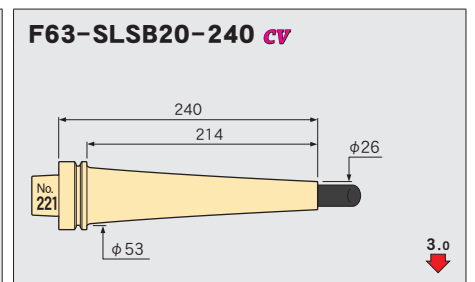
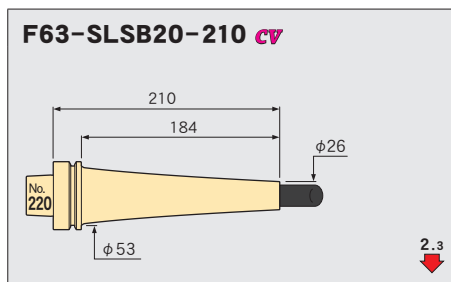
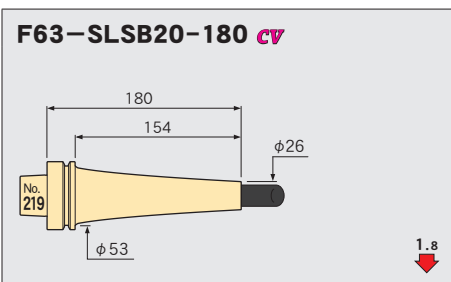
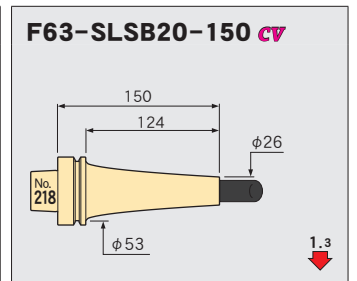
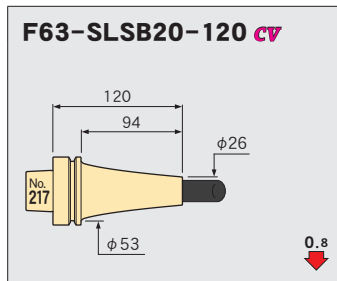
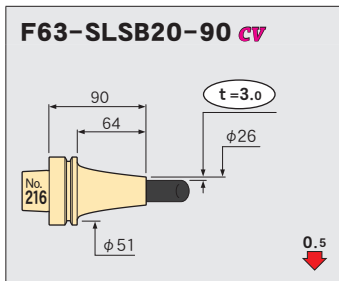
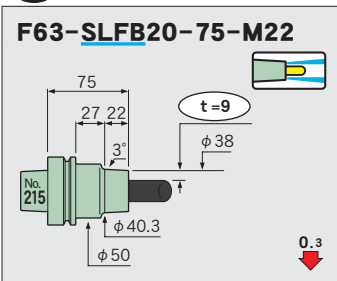

F63-SLSB20-270 CV

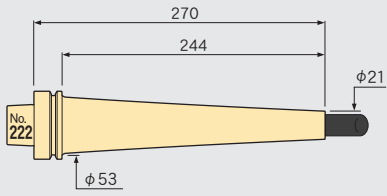

φ 3/4

F63-SLSB3/4-90 CV

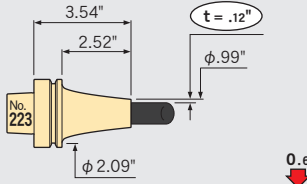

F63-SLSB3/4-120 CV

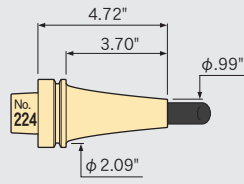

F63-SLSB3/4-150 CV

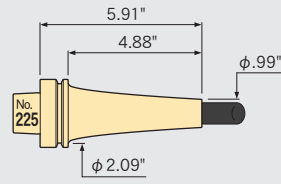

F63-SLSB3/4-180 CV

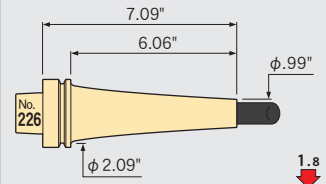

F63-SLSB3/4-210 CV

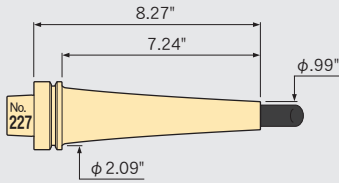

F63-SLSB3/4-240 CV

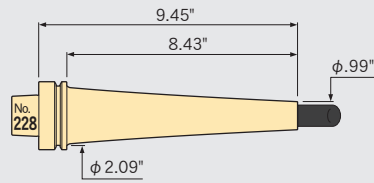

F63-SLSB3/4-270 CV

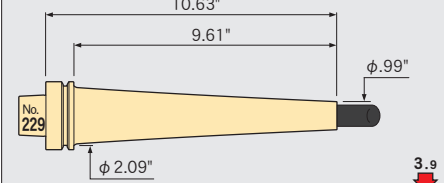

φ 25

F63-SLFB25-75-M22

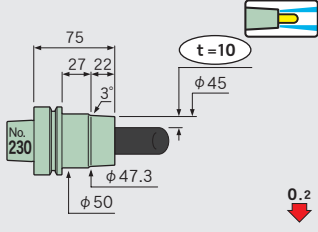

Feature
Shrink-fit Heater

MONO 3°
MONO CURVE

MONO Series

2PIECE type

UNO

HYPER
version

STRAIGHT
arbor

OTHERS

PERIPHERALS

Technical
data

15T

MONO 3°

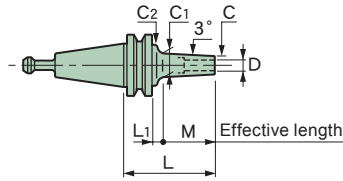
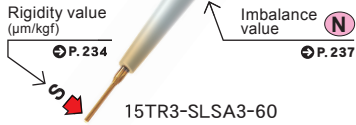

Caution
 • Setting cutters --Be sure to insert the tool beyond the safety mark.

BROTHER TC-20A TC-20B

Compatibility table for HRD-01S
 [O] Available [X] Not available

CODE	φD	φC	t	L	M	L1	φC1	φC2	H	h	Kg	N	S	Scale model	
15TR3-SLSA 3-40	3	6	1.5	40	22	5.5	8.3	18	9	46	0.1	0.3	4.7	○	1
				60	42		10.4			66			9.3		2
15TR3-SLSA3.175-40	3.175	6.175	1.5	40	22	5.5	8.5	18	9	46	0.1	0.3	4.4	○	3
				60	42		10.6			66			8.8		4
15TR3-SLSA 4-40	4	7	1.5	40	22	5.5	9.3	18	12	46	0.1	0.3	3.6	○	5
				60	42		11.4			66			7.3		6
15TR3-SLSA 5-40	5	8	1.5	40	22	5.5	10.3	18	15	46	0.1	0.3	2.9	○	7
				60	42		12.4			66			5.9		8
15TR3-SLSA 6-60	6	9	1.5	60	42	5.5	13.4	18	18	66	0.1	0.4	4.9	○	9
				-SLRA 6-35	12		3			35			19.6		2.9
15TR3-SLRA 8-35	8	14	3	35	19.6	2.9	16.1	—	20	51	0.1	0.3	0.9	×	11
15TR3-SLRA10-35	10	16	3	35	19.6	2.9	18.1	—	20	51	0.1	0.4	0.8	×	12

S=1:3

S20T

MONO 3°

Rigidity value
($\mu\text{m}/\text{kgf}$)

Ⓟ P. 234

50

Imbalance value

Ⓝ

Ⓟ P. 237

S20TR2-SLRA8-35

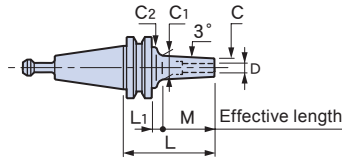

Caution

- Setting cutters · Be sure to insert the tool beyond the safety mark.

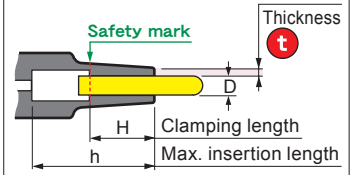

SUGINO

V9 / NSV9 / H5 / H7 / H9



Thickness



Compatibility table for HRD-01S

[O] Available [X] Not available

CODE	ϕD	ϕC	t	L	M	L ₁	ϕC_1	ϕC_2	H	h	Kg	N	S	Scale model
S20TR2-SLSA 3-40	3	6	1.5	40	22	5.5	8.3	20	9	46	0.1	0.4	4.6	1
				60	42		10.4			66			9.2	
S20TR2-SLSA3.175-40	3.175	6.175	1.5	40	22	5.5	8.5	20	9	46	0.1	0.4	4.4	3
				60	42		10.6			66			8.8	
S20TR2-SLSA 4-40	4	7	1.5	40	22	5.5	9.3	20	12	46	0.1	0.4	3.6	5
				60	42		11.4			66			7.2	
S20TR2-SLSA 5-40	5	8	1.5	40	22	5.5	10.3	20	15	46	0.1	0.4	2.8	7
				60	42		12.4			66			5.8	
S20TR2-SLSA 6-60	6	9	1.5	60	42	5.5	13.4	20	18	66	0.1	0.5	4.7	9
				-SLRA 6-35	12		3			35			19.6	
S20TR2-SLRA 8-35	8	14	3	35	19.6	2.9	16.1	—	20	51	0.1	0.4	0.9	11
S20TR2-SLRA10-35	10	16	3	35	19.6	2.9	18.1	—	20	51	0.1	0.5	0.8	12
S20TR2-SLRA12-45	12	20	4	45	32.5	—	23.4	—	30	51	0.2	0.6	0.8	13

S=1:4

Ⓟ 3

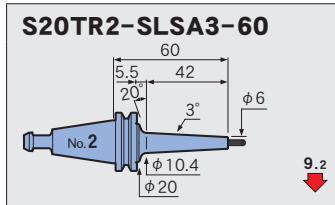
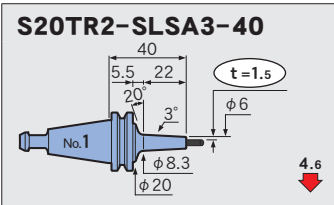

Ⓟ 3.175

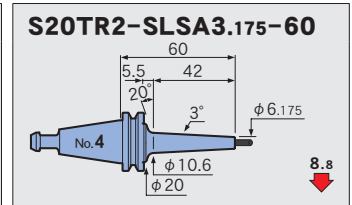
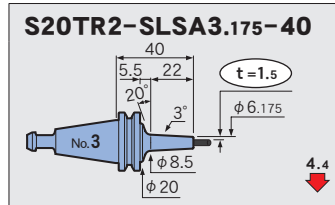

Ⓟ 4

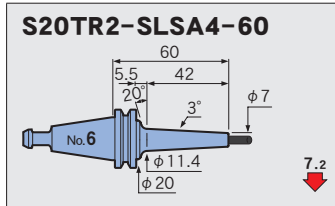
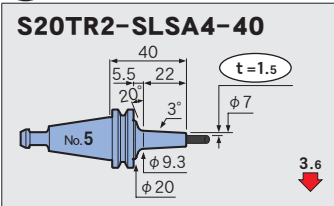

Ⓟ 5

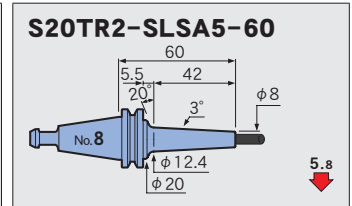
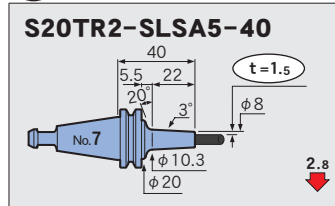

Ⓟ 6

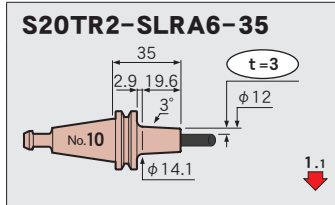
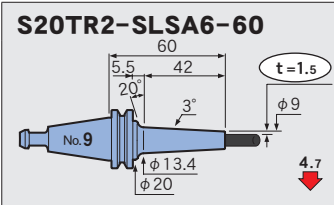

Ⓟ 8

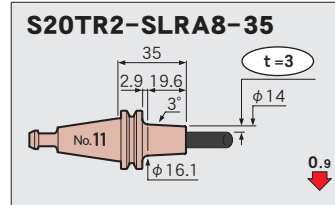

Ⓟ 10

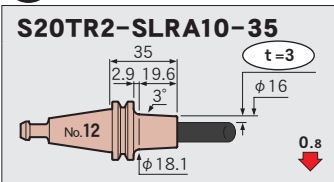

Ⓟ 12

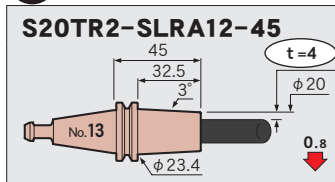

RS20

MONO 3°

Rigidity value (μm/kgf)
P.234

Imbalance value (N)
P.237

RS20-SLSA3.175-35

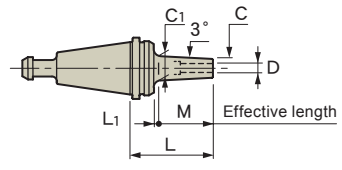

Caution
Setting cutters... Be sure to insert the tool beyond the safety mark.

ROKU-ROKU
MEGA

Compatibility table for HRD-01S
[O] Available [X] Not available

CODE	φD	φC	t	L	M	L ₁	φC ₁	H	h	Kg	N	S	縮図
RS20-SLSA 3-35	3	6	1.5	35	22.1	2.9	8.3	9	46	0.1	0.2	5.2	○ 1
RS20-SLSA 3.175-35	3.175	6.175	1.5	35	22.1	2.9	8.5	9	46	0.1	0.2	4.9	○ 2
RS20-SLSA 4-35	4	7	1.5	35	22.1	2.9	9.3	12	46	0.1	0.2	4	○ 3
RS20-SLSA 5-35	5	8	1.5	35	22.1	2.9	10.3	15	46	0.1	0.2	3.2	○ 4
RS20-SLRA 6-30	6	12	3	30	17.1	2.9	13.8	18	46	0.1	0.2	1.1	× 5
RS20-SLRA 8-30	8	14	3	30	17.2	2.8	15.8	20	51	0.1	0.3	0.9	× 6
RS20-SLRA10-30	10	16	3	30	17.6	2.4	17.9	20	51	0.1	0.4	0.7	× 7

S=1:2.5

φ3
RS20-SLSA3-35
Dimensions: 35, 2.9, 22.1, t=1.5, φ6, φ8.3, 3°, 5.2

φ3.175
RS20-SLSA3.175-35
Dimensions: 35, 2.9, 22.1, t=1.5, φ6.175, φ8.5, 3°, 4.9

φ4
RS20-SLSA4-35
Dimensions: 35, 2.9, 22.1, t=1.5, φ7, φ9.3, 3°, 4.0

φ5
RS20-SLSA5-35
Dimensions: 35, 2.9, 22.1, t=1.5, φ8, φ10.3, 3°, 3.2

φ6
RS20-SLRA6-30
Dimensions: 30, 2.9, 17.1, t=3, φ12, φ13.8, 3°, 1.1

φ8
RS20-SLRA8-30
Dimensions: 30, 2.8, 17.2, t=3, φ14, φ15.8, 3°, 0.9

φ10
RS20-SLRA10-30
Dimensions: 30, 2.4, 17.6, t=3, φ16, φ17.9, 3°, 0.7

CT50

MONO CURVE

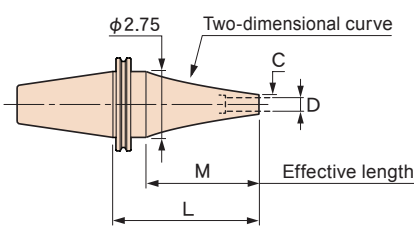

Option

- Retention knob

Caution

- Retention knob... Use a retention knob with hole, or remove the retention knob and heat it.
- Setting cutters... Be sure to insert the tool beyond the safety mark.

Compatibility table for HRD-01S

[O] Available [X] Not available
[▲] Usable by raising the heating unit. → P.233

CODE	φD	φC	t	L	M	H	h	lbs	N	S	Scale model
CT50-SLSA3/16-165 CV	3/16	.31	.06	6.50	5.12	.59	8.66	8.4	13.7	2.6	○
-195 CV				7.68	6.30		9.84	8.7	14.7	4	○
-225 CV				8.86	7.48		11.02	9.1	15.7	5.9	○
-255 CV				10.04	8.66		12.20	9.4	17.4	8.2	▲
-285 CV				11.22	9.84		13.39	10.0	18.9	10.5	○
-315 CV				12.40	11.02		14.57	10.5	20.5	13.3	○
CT50-SLSA1/4 -165 CV	1/4	.37	.06	6.50	5.12	.71	8.66	8.5	13.1	2.4	○
-195 CV				7.68	6.30		9.84	9.6	16	2.5	○
-225 CV				8.86	7.48		11.02	10.0	16.9	3.9	○
-255 CV				10.04	8.66		12.20		19.2	5.6	▲
-285 CV				11.22	9.84		13.39	10.5	20.8	7.4	○
-315 CV				12.40	11.02		14.57	11.1	22.4	9.5	○
CT50-SLSA5/16-165 CV	5/16	.49	.06	6.50	5.12	.94	8.66	9.0	15.2	1.5	○
-195 CV				7.68	6.30		9.84	9.3	16.2	2.4	○
-225 CV				8.86	7.48		11.02	9.4	17.5	3.9	○
-255 CV				10.04	8.66		12.20	9.9	19.1	5.2	▲
-285 CV				11.22	9.84		13.39	10.8	21.6	6	○
-315 CV				12.40	11.02		14.57	11.7	23.9	7.1	○
-SLRA5/16-195 CV	5/16	.63	.16	7.68	6.30	.94	9.84	9.6	17	1.5	○
-225 CV				8.86	7.48		11.02	10.8	19.9	1.6	○
-255 CV				10.04	8.66		12.20	10.9	20.4	2.6	▲
-285 CV				11.22	9.84		13.39	11.6	23.5	3.2	○
-SLFA5/16-195 CV	5/16	.63	.16	7.68	6.30	.94	9.84	9.6	17	1.5	○
-225 CV				8.86	7.48		11.02	10.8	19.9	1.6	○
-255 CV				10.04	8.66		12.20	10.9	20.4	2.6	▲
-285 CV				11.22	9.84		13.39	11.6	23.5	3.2	○
CT50-SLSA3/8 -165 CV	3/8	.49	.06	6.50	5.12	1.18	8.66	8.9	14.9	1.5	○
-195 CV				7.68	6.30		9.84	9.1	15.8	2.4	○
-225 CV				8.86	7.48		11.02	9.3	16.7	3.8	▲
-255 CV				10.04	8.66		12.20	9.8	19.3	5	○
-285 CV				11.22	9.84		13.39	11.0	22.5	5.2	○
-315 CV				12.40	11.02		14.57	11.5	24.4	6.9	○

Feature: Shrink-fit Heater
MONO 3° MONO CURVE
MONO Series
2PIECE type
UNO
HYPER version
STRAIGHT arbor
OTHERS
PERIPHERALS
Technical Information

CODE	φD	φC	t	L	M	H	h	lbs	N	S	HRD-01S	Scale model
CT50-SLRA3/8-165 CV	3/8	.73	.18	6.50	5.12	1.18	8.66	8.8	15.4	1	×	33
-195 CV				7.68	6.30		9.84	9.2	16.9	1.5	○	34
-225 CV				8.86	7.48		11.02	10.1	18.5	1.9	▲	35
-255 CV				10.04	8.66		12.20		20.1	3		36
-285 CV				11.22	9.84		13.39	11.3	23.3	3.3		37
-SLFA3/8-165 CV	3/8	.73	.18	6.50	5.12	1.18	8.66	8.8	15.4	1	×	38
-195 CV				7.68	6.30		9.84	9.2	16.9	1.5	○	39
-225 CV				8.86	7.48		11.02	10.1	18.5	1.9	▲	40
-255 CV				10.04	8.66		12.20		20.1	3		41
-285 CV				11.22	9.84		13.39	11.3	23.3	3.3		42
CT50-SLSA1/2-165 CV	1/2	.62	.06	6.50	5.12	1.18	8.66	8.9	15.8	1.2	○	43
-195 CV				7.68	6.30		9.84	9.3	17.5	1.9		44
-225 CV				8.86	7.48		11.02	9.8	19.1	2.7		45
-255 CV				10.04	8.66		12.20	10.3	20.8	3.8	▲	46
-285 CV				11.22	9.84		13.39	10.7	26.5	4.7		47
-315 CV				12.40	11.02		14.57	11.4	28.8	5.2		48
-SLRA1/2-165 CV	1/2	.89	.20	6.50	5.12	1.18	8.66	9.2	16.4	0.8	×	49
-195 CV				7.68	6.30		9.84	9.5	17.8	1.3		50
-225 CV				8.86	7.48		11.02	10.7	21	1.4	○	51
-255 CV				10.04	8.66		12.20	11.0	22.4	2.1	▲	52
-285 CV				11.22	9.84		13.39	11.9	29.6	2.3		53
-SLFA1/2-165 CV	1/2	.89	.20	6.50	5.12	1.18	8.66	9.2	16.4	0.8	×	54
-195 CV				7.68	6.30		9.84	9.5	17.8	1.3		55
-225 CV				8.86	7.48		11.02	10.7	21	1.4	○	56
-255 CV				10.04	8.66		12.20	11.0	22.4	2.1	▲	57
-285 CV				11.22	9.84		13.39	11.9	29.6	2.3		58
CT50-SLSB5/8-165 CV	5/8	.82	.10	6.50	5.12	1.26	8.66	8.6	17.5	1.1		59
-195 CV				7.68	6.30		9.84	9.3	20.2	1.5		60
-225 CV				8.86	7.48		11.02	9.9	22.9	2		61
-255 CV				10.04	8.66		12.20	10.1	24.3	3.1		62
-285 CV				11.22	9.84		13.39	10.7	27	3.9		63
-315 CV	12.40	11.02	14.57	11.4	29.7	4.8		64				
CT50-SLSB3/4-165 CV	3/4	.99	.12	6.50	5.12	1.50	8.66	9.1	19	0.8		65
-195 CV				7.68	6.30		9.84	9.7	21.9	1.2		66
-225 CV				8.86	7.48		11.02	9.8	23.9	1.8		67
-255 CV				10.04	8.66		12.20	10.4	26.8	2.5		68
-285 CV				11.22	9.84		13.39	11.1	29.7	3.2		69
-315 CV	12.40	11.02	14.57	11.7	32.6	4.1		70				

■ Cleaning tool for a spindle taper hole, STAR DUST

CODE
CLT-NT50-G3

Ⓜ P.226



Feature

Shrink-fit Heater

MONO 3° MONO CURVE

MONO Series

2PIECE type

UNO

HYPER version

STRAIGHT arbor

OTHERS

PERIPHERALS

Technical Information

$\phi 3/16$

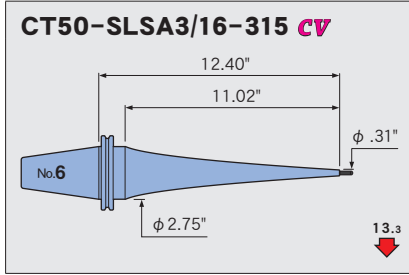
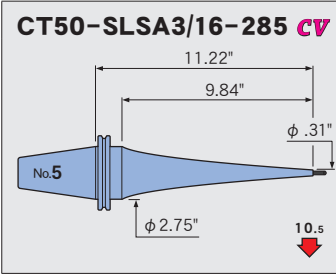
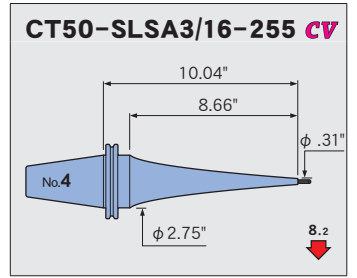
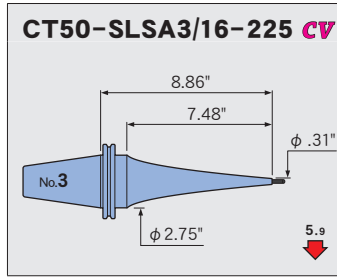
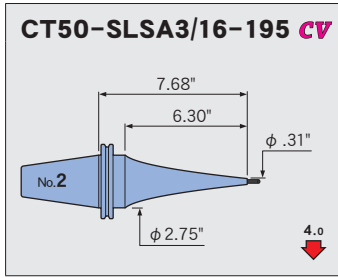
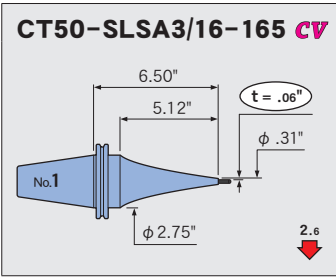

$\phi 1/4$

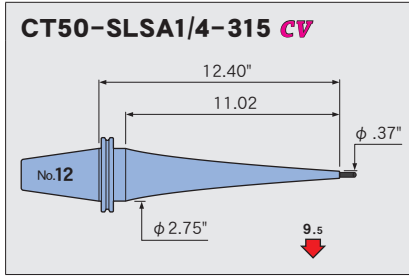
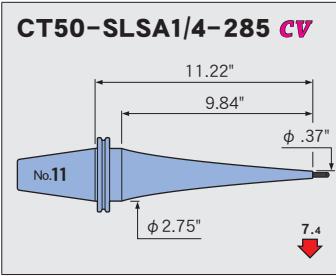
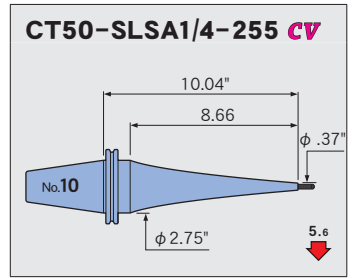
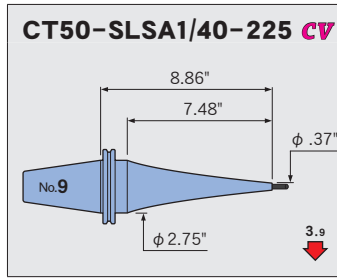
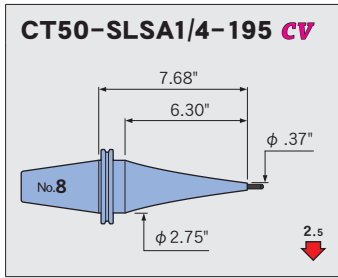
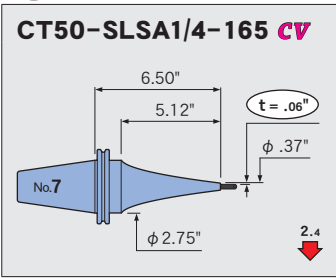

$\phi 5/16$

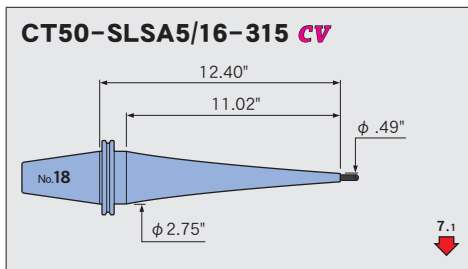
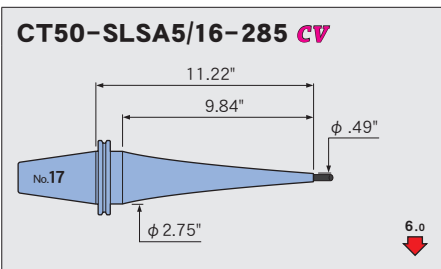
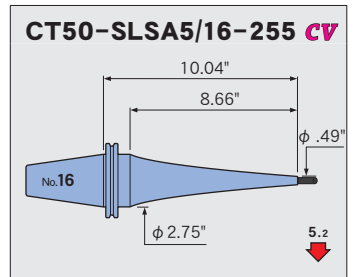
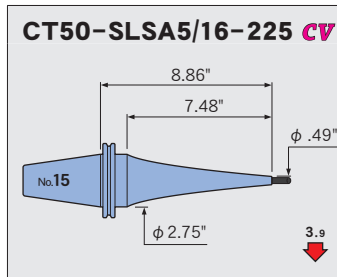
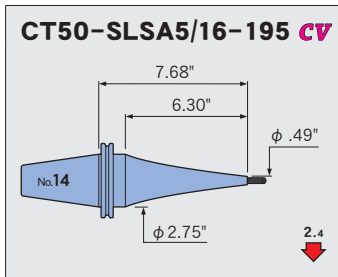
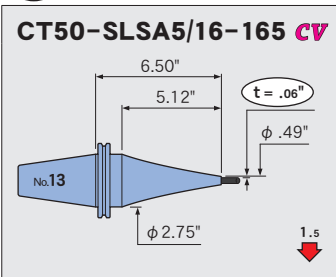

Feature

Shrink-fit Heater

MONO 3°
MONO CURVE

MONO Series

2PIECE type

UNO

HYPER
version

STRAIGHT
anbor

OTHERS

PERIPHERALS

Technical
Information

Feature
Shrink-fit Heater
MONO 3° MONO CURVE
MONO Series
2PIECE type
UNO
HYPER version
STRAIGHT anbor
OTHERS
PERIPHERALS
Technical Information

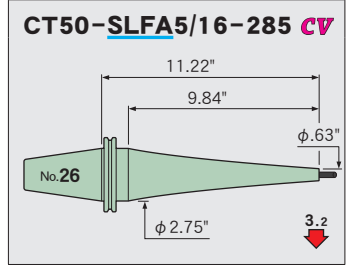
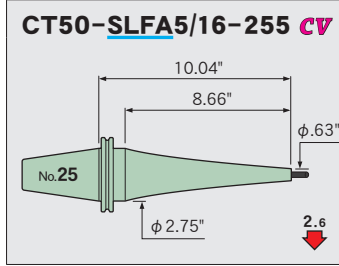
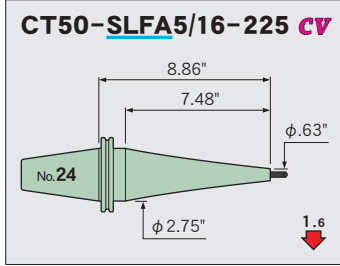
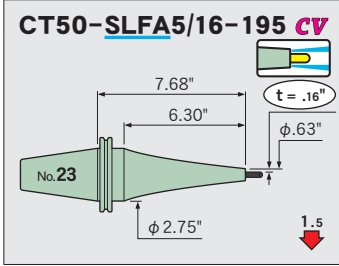
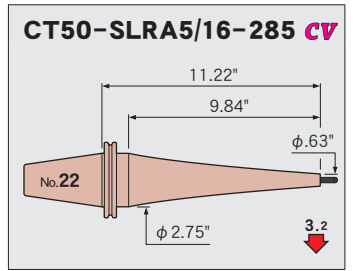
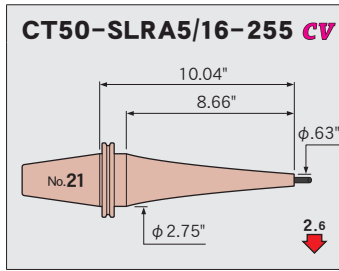
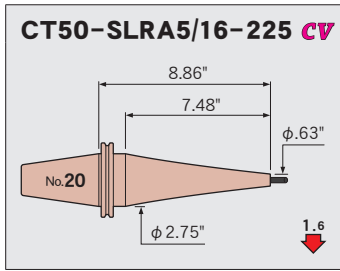
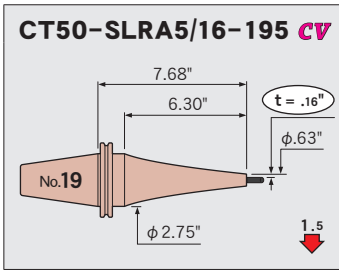

φ 3/8

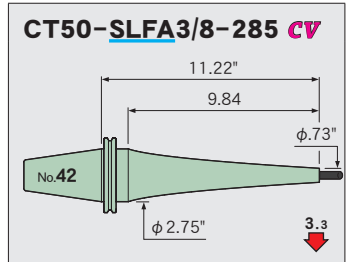
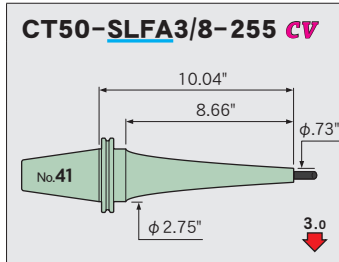
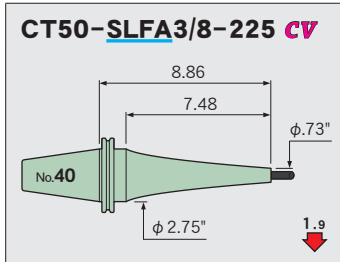
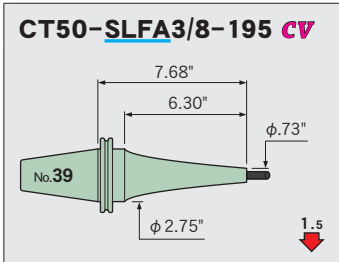
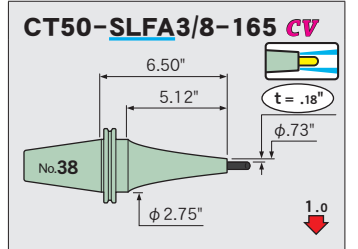
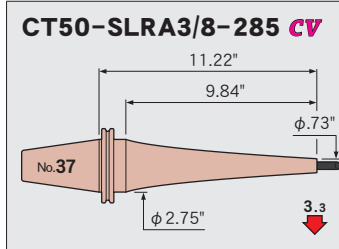
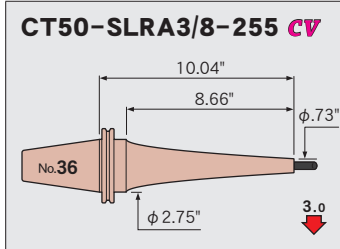
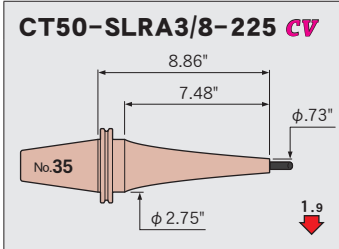
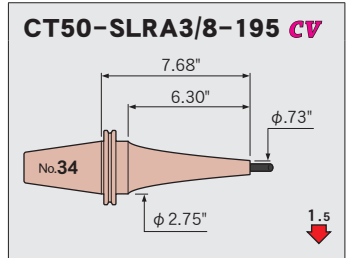
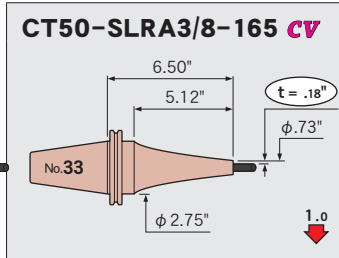
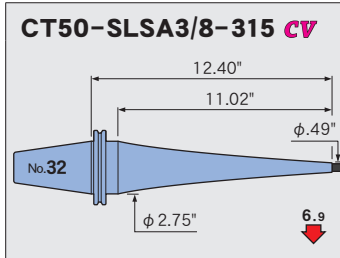
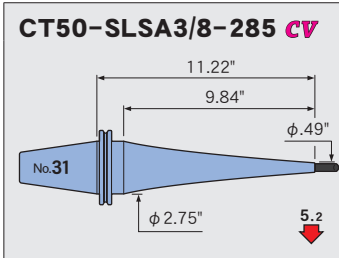
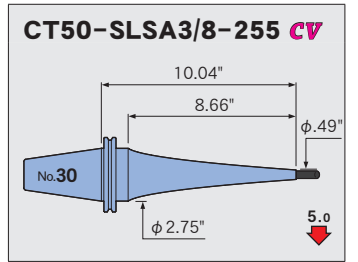
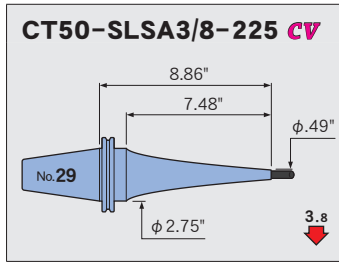
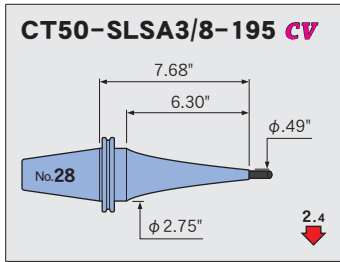
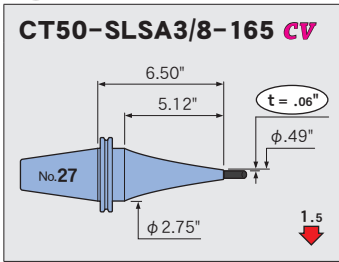

$\phi 1/2$

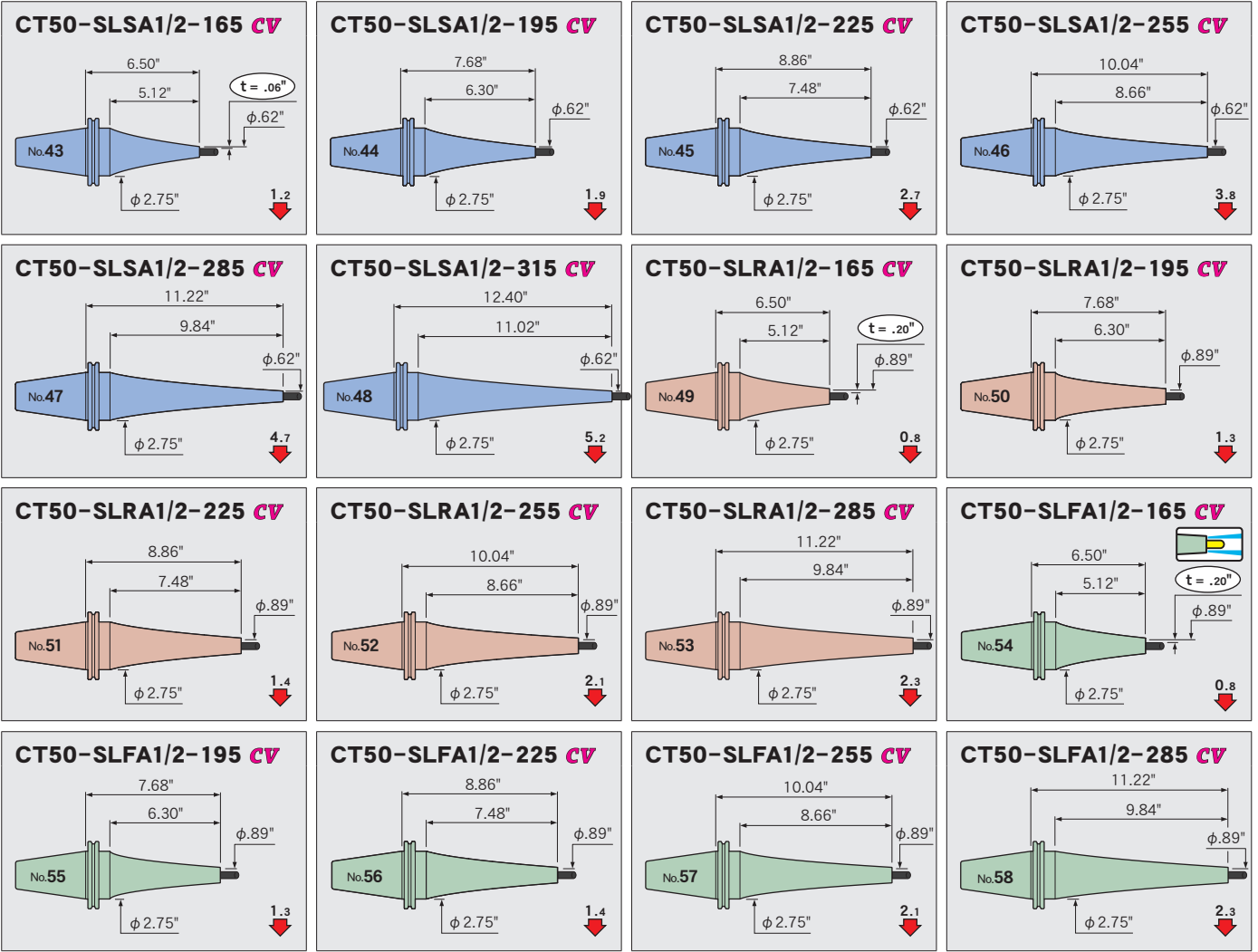

$\phi 5/8$

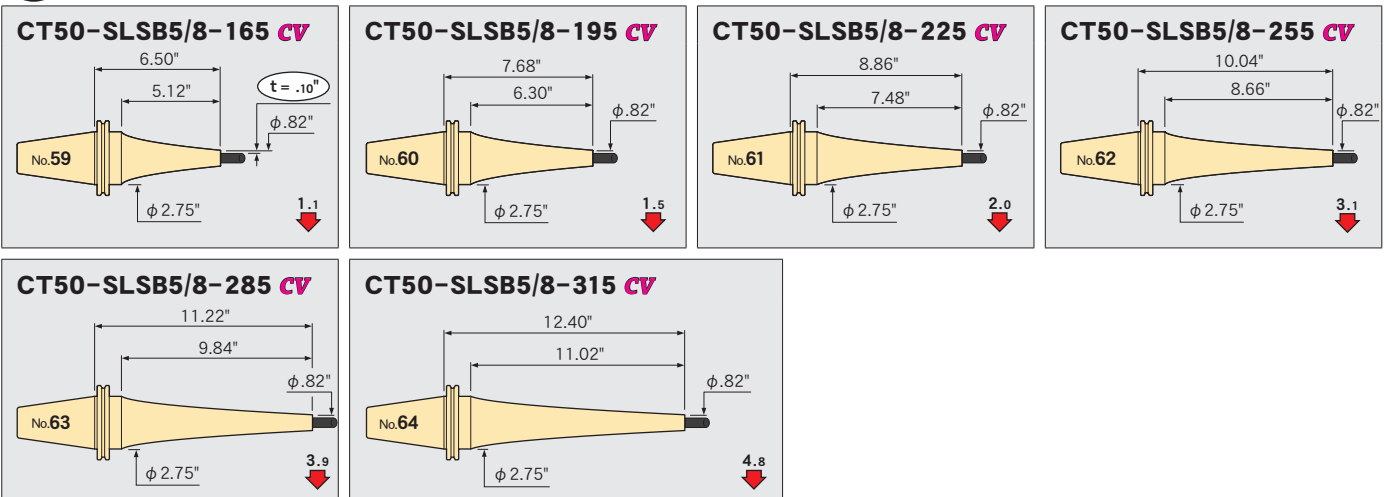

Feature

Shrink-fit Heater

MONO 3°
MONO CURVE

MONO Series

2PIECE type

UNO

HYPER
version

STRAIGHT
airbor

OTHERS

PERIPHERALS

Technical
Information

$\phi 3/4$

Feature

Shrink-fit Heater

MONO 3°
MONO CURVE

MONO Series

2PIECE type

UNO

HYPER
version

STRAIGHT
arbor

OTHERS

PERIPHERALS

Technical
Information

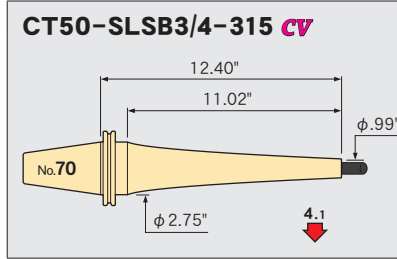
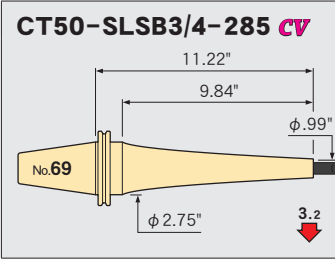
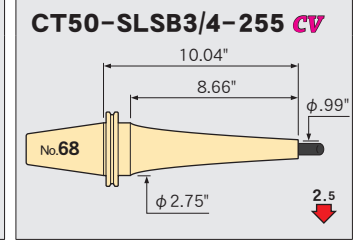
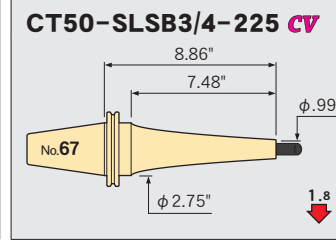
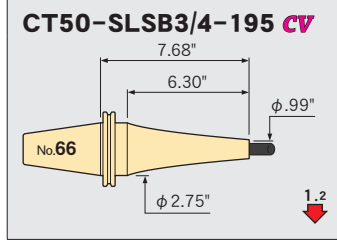
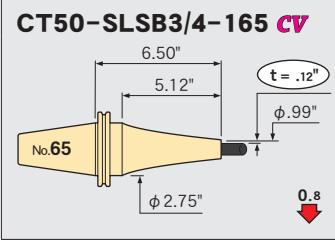

2 PIECE type

■ Versatile and economical modular type

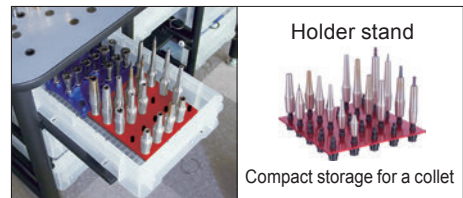
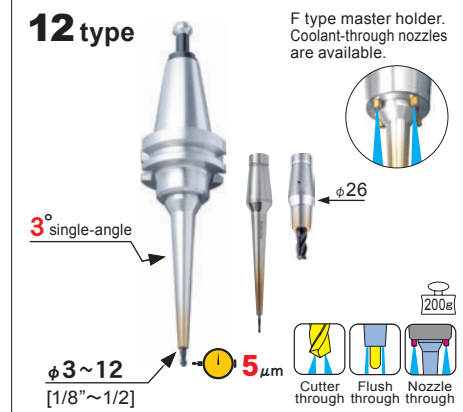
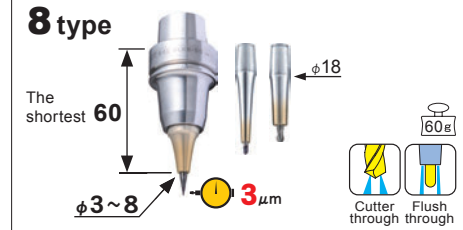
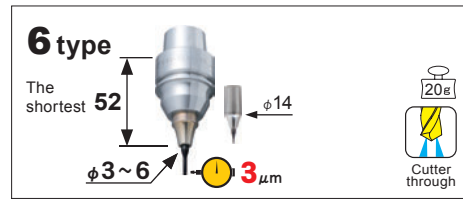
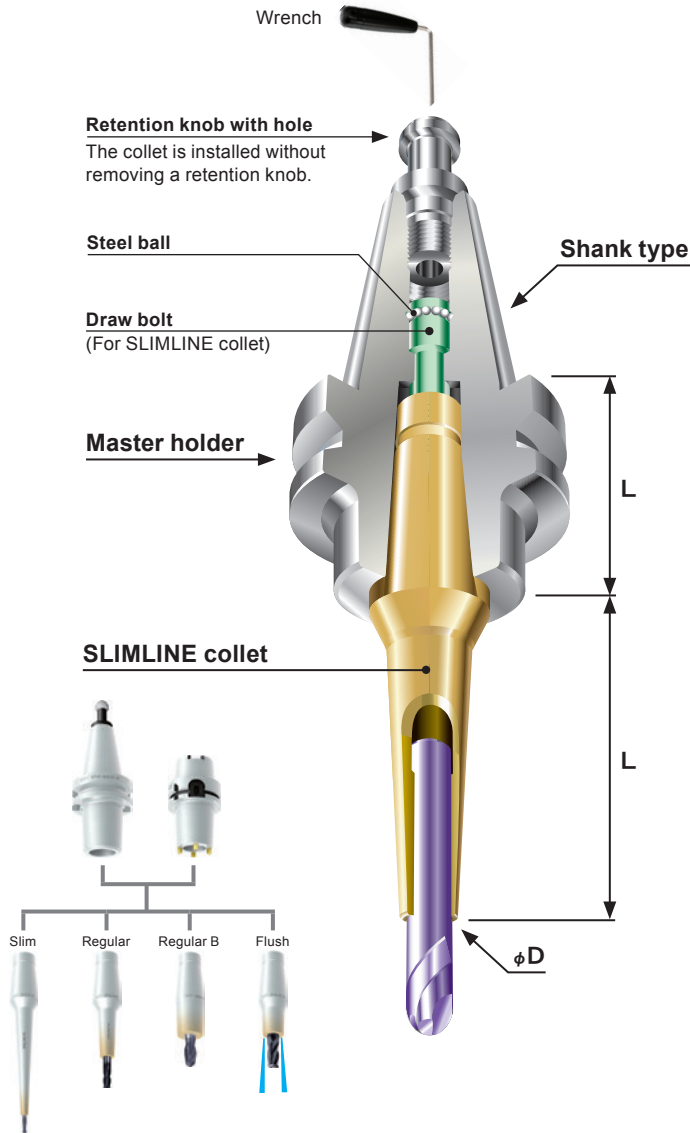

Master holder

BT40 - SLK 12 - 45 F

Shank type SLIMLINE type L Coolant-through

PAGE			Inch
190	6 type	BT30 HSK-A40, A50 HSK-E32, E40, E50	—
191	8 type	BT30, BT40 HSK-A40, A50, A63 HSK-E40, E50, F63	—
192	12 type	BT30, BT40, BT50 HSK-A50, A63, A100 HSK-E50, F63 DN40, DN50 CT40, CT50	○

SLIMLINE collet

CR 12 - 4 - 80

Collet type ϕD L

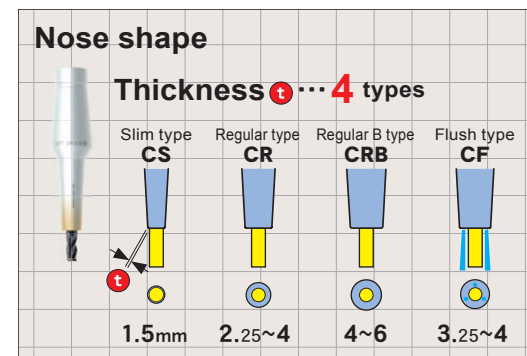

Master holder 6 type

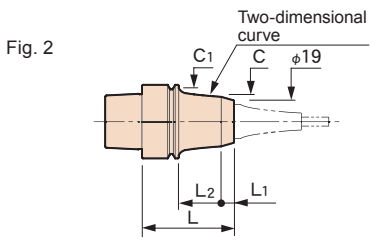
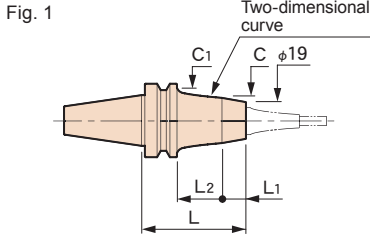

CODE	Fig.	L	L1	L2	φC	φC1	Kg	N
BT30-SLK 6-35-MAS1	1	35	13	—	—	34	0.5	1.4
-MAS2		65	15	28	25.1	34	0.6	2.2
-65-MAS1								
-MAS2								
A40 -SLK 6-37	2	37	17	—	—	34	0.2	3
-50		50	7	23	23.5	34	0.3	3.9
A50 -SLK 6-42	2	42	16	—	—	42	0.4	5.3
-55		55	7	22	24.6	42	0.5	6.4
E32 -SLK 6-37	2	37	7	10	26	—	0.2	1.3
-50		50	—	23	—	—	—	2.2
E40 -SLK 6-37	2	37	17	—	—	34	0.3	1.7
-50		50	7	23	23.5	34	—	2.6
E50 -SLK 6-42	2	42	16	—	—	42	0.5	3.4
-55		55	7	22	24.6	42	0.6	4.4

- Option**
 - SLIMLINE collet 6 type
 - Wrench.
- Std. Access.**
 - Coolant duct (HSK-A)
 - Retention knob (BT30)
- Note**
 - A dedicated retention knob is supplied with the BT30 as a standard accessory. When ordering, specify machine maker and model number. To replace the retention knob, please contact us.
- Caution**
 - If the SLIMLINE collet can't be removed from a master holder, follow the procedure on P.232.
 - HSK-E shank doesn't come with a coolant duct and cannot be attached. Consult us if you need it.

SLIMLINE collet 6 type

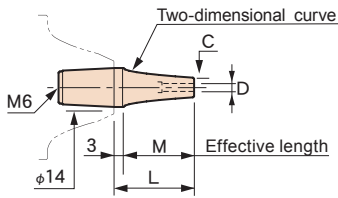
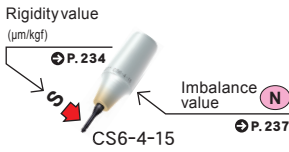

- Note**
 - **S** refers to the deflection value of an E32-SLK6-37 and the SLIMLINE collet 6 type combination. The values are comparable for any shank combination.
- Caution**
 - Setting cutters... Be sure to insert the tool beyond the safety mark.

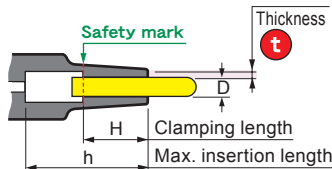

CODE	φD	φC	t	L	M	H	S	N	g	h
CS6-3-15	3	6	1.5	15	12	9	1.5	0.1	20	24
-30				30	27		3.2	0.2	30	39
-45				45	42		9	0.3	40	54
CR6-3-30	3	7.5	2.25	30	27	9	1.3	0.1	30	39
-45				45	42		6.2	0.3	40	54
CS6-4-15	4	7	1.5	15	12	12	1.2	0.1	30	24
-30				30	27		2.8	0.2	—	39
-45				45	42		7.9	0.4	40	54
CR6-4-30	4	10	3	30	27	12	1	0.1	30	39
-45				45	42		4.4	0.5	50	54
CS6-6-15	6	9	1.5	15	12	15	1	0.1	20	24
-30				30	27		2.4	0.3	30	35
-45				45	42		6.5	0.5	40	—
CR6-6-30	6	12	3	30	27	15	0.8	0.2	20	35
-45				45	42		4	0.6	—	—

⚠ Don't insert the cutter shank to the max. insertion length (h).

If the cutting tool shank face touches the bottom of the holder, the collet will not be installed properly and it may cause poor accuracy. Be sure to pay attention to this by using CS6 and CS8 with L = 15 and 25, because their "h" dimension is very short.

We recommend you use the short overall length tool for SLIMLINE (6 type • 8 type) because its insertion length is short. When cutting off a tool shank, please remove any burrs on the cutting surface of the tool shank carefully.

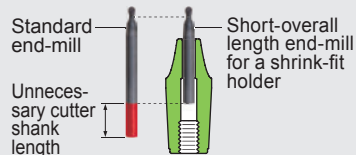
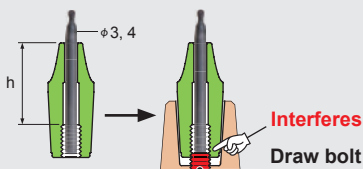

Wrench (both for 6 and 8 type)

Used for clamping of master holders (type 6 & type 8) and SLIMLINE collet (type 6 & type 8).



CODE	Shank type
TW- 4	HSK-A, E, F, BT40
DW-14	BT30

Cleaning tool, STAR DUST

• P.226



Holder stand

• P.16



Master holder 8 type



Fig. 1

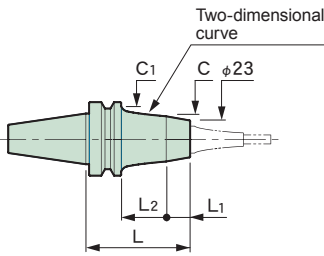
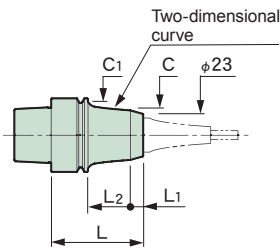

Fig. 2



CODE	Fig.	L	L ₁	L ₂	φC	φC ₁	Kg	N
BT30-SLK8-35-MAS1	1	35	13	—	—	34	0.4	1.5
-MAS2								
-65-MAS1		65	15	28	27.5		0.6	2.3
-MAS2								
BT40-SLK8-40	1	40	13	—	—	53	1	1.8
-70		70	15	28	31.2		1.2	2.5
A40-SLK8-50	2	50	7	23	27	34	0.3	2.5
-70		70	15	35	27.3		0.4	3.3
A50-SLK8-55	2	55	7	22	28.1	42	0.5	4
-75		75	15	34	28.7		0.6	4.8
A63-SLK8-55	2	55	7	22	29.5	53	0.8	5.7
-75		75	15	34	30.5		0.9	5.9
E40-SLK8-50	2	50	7	23	27	34	0.3	2.1
-70		70	15	35	27.3		0.4	2.9
E50-SLK8-55	2	55	7	22	28.1	42	0.6	2.7
-75		75	15	34	28.7		0.7	3.5
F63M-SLK8-55	2	55	7	22	29.5	53	0.8	4.4
-75		75	15	34	30.5		1	5.2

Option

- SLIMLINE collet 8 type
- Wrench
- Retention knob (BT40)→P.216

Std. Access.

- Coolant duct (HSK-A)
- Retention knob (BT30)

Note

- A dedicated retention knob is supplied with the BT30 as a standard accessory. When ordering, specify machine maker and model number. To replace the retention knob, please contact us.

Caution

- If the SLIMLINE collet can't be removed from a master holder, follow the procedure on p.232.
- HSK-E and F shank don't come with a coolant duct and cannot be attached. Consult us if you need it.

SLIMLINE collet 8 type

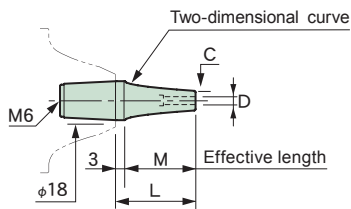
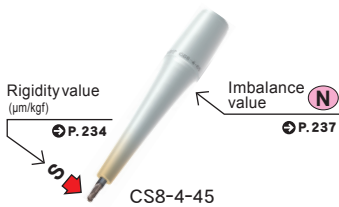

Note

- S_{\downarrow} refers to the deflection value of an E40-SLK8-50 and SLIMLINE collet type 8 combination. The values are comparable for any shank combination.

Caution

- Setting cutters...Be sure to insert the tool beyond the safety mark.

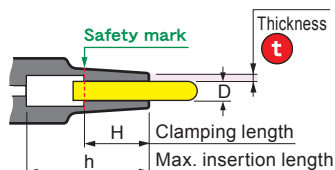

CODE	φD	φC	t	L	M	H	S _↓	N	g	h
CS8-3-25	3	6	1.5	25	22	9	2.1	0.2	60	37.5
-45				45	42		4.8	0.4	70	57.5
-65				65	62		10.3	0.6	80	77.5
CR8-3-45	3	7.5	2.25	45	42	9	3.6	0.5	70	57.5
-65				65	62		7.4	0.7	90	77.5
CF8-3-45	3	9.5	3.25	45	42	9	2.8	0.5	80	57.5
-65				65	62		5.3	0.8	100	77.5
CS8-4-25	4	7	1.5	25	22	12	1.8	0.3	60	37.5
-45				45	42		4.4	0.5	70	57.5
-65				65	62		9.2	0.6	80	77.5
CR8-4-45	4	10	3	45	42	12	2.7	0.6	80	57.5
-65				65	62		5.3	0.8	100	77.5
CF8-4-45	4	12	4	45	42	12	2.3	0.7	90	57.5
-65				65	62		4.2	0.9	110	77.5
CS8-6-25	6	9	1.5	25	22	15	1.5	0.3	60	35
-45				45	42		3.7	0.6	80	
-65				65	62		7.6	0.8	90	
CR8-6-45	6	12	3	45	42	15	2.5	0.7	90	35
-65				65	62		4.8	1	110	
CF8-6-45	6	14	4	45	42	15	2.1	0.8	100	35
-65				65	62		3.9	1.1	120	
CS8-8-25	8	11	1.5	25	22	20	1.4	0.4	60	37
-45				45	42		3.3	0.7	70	49
CR8-8-45	8	14	3	45	42	20	2.4	0.8	90	49
CF8-8-45				45	42		20	2.1	1.1	110



Master holder 12 type



Fig. 1

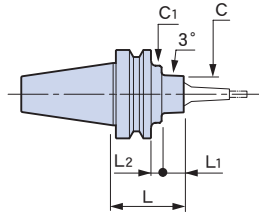

Fig. 2

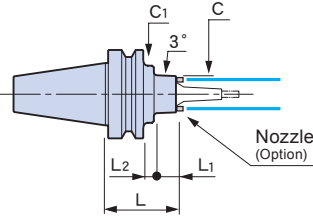

Fig. 3

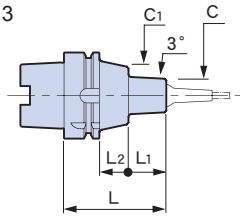

Fig. 4

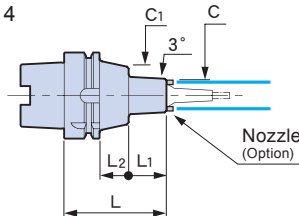
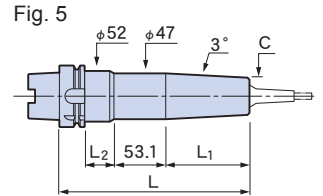

Fig. 5



CODE	Fig.	L	φC	L ₁	L ₂	φC ₁	Kg	(N)
BT30-SLK12- 35-MAS1	1	35	38	13	—	—	0.4	1
-MAS2								
BT40-SLK12- 45	1	45	38	18	—	—	1.1	1.4
- 45F	2		41					1.6
- 75	1	75	38	48			1.4	
- 75F	2		41					1.8
-135F		135		108			2.2	3.2
BT50-SLK12- 75	1	75	38	25	12	65	4	4.7
- 75F	2		41					4.9
-105F		105		55			4.4	5.3
-135F		135		85			4.7	5.7
-225	1	225	38	175			6.4	14.8
-315		315		225	52		11	31.3
A50 -SLK12- 75	3	75	38	49	—	—	0.8	4.8
A63 -SLK12- 75	3	75	38	49	—	—	1	5
- 75F	4		41				1.1	5.5
-135	3	135	38	109			1.7	8.5
-135F	4		41				1.9	8.6
NEW -165	5	165	38	86			2.2	16.7
-195		195			30		2.7	21.0
-225		225			60		3.2	25.3
A100-SLK12-105	3	105	38	43	33	65	3.5	22.6
-105F	4		41				3.5	23.4
-135F		135		73			3.9	25.4
-225	3	225	38	163			5.2	35.7
-315		315		253			6.9	47.6
E50 -SLK12- 75	3	75	38	49	—	—	0.8	2.9
F63M-SLK12- 75	3	75	38	49	—	—	1	3.4
DN40AD-SLK12- 45	1	45	38	13.8	12.1	45	1	4.6
- 45F	2		41	7.9	18			4.3
- 75	1	75	38	43.8	12.1		1.3	5.8
- 75F	2		41	55.9	—			5.5
DN50AD-SLK12- 75	1	75	38	40	15.9	70	3.4	12.6
- 75F	2						3.5	12.3
-135F		135	41	100			4.3	19



CODE	Fig.	L	φC	L1	L2	φC1	lbs	N
CT40-SLK12- 45	1	1.77	1.61	1.02	—	1.75	2.4	2.4
- 45F	2						2.2	2.8
- 75	1	2.95	1.50	2.20			2.9	3.5
- 75F	2		1.61				3.1	3.9
-135F		5.31		4.56			4.6	6.8
CT50-SLK12- 75	1	2.95	1.50	1.57	.63	2.75	7.5	7.9
- 75F	2		1.61				7.7	8.3
-105F		4.13		2.76			8.6	11.3
-135F		5.31		3.94			9.5	14.4
-225	1	8.86	1.50	7.48			12.6	23
-315		12.40		8.86	2.79		17.6	28



Option

- SLIMLINE collet 12type
- Wrench (W-135)
- Nozzles (nozzle model: NOZ)
- Retention knob (BT40, 50/ CAT./ DIN)→P.216

Std. Access.

- Coolant duct (HSK-A)
- Retention knob (BT30)

Note

- A dedicated retention knob is supplied with the BT30 as a standard accessory. When ordering, specify machine maker and model number. To replace the retention knob, please contact us.

Caution

- If the SLIMLINE collet can't be removed from a master holder, follow the procedure on p.232.
- HSK-E and F shank don't come with a coolant duct and cannot be attached. Consult us if you need it.

Wrench

Required for clamping the master holder and SLIMLINE collet.

CODE
W-135

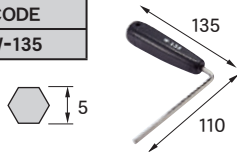

Note

- To fasten the BT30, use a commercially available 14 mm single-ended wrench.

Nozzle (For F-type)

CODE	Q'ty
NOZ-M4-12	12
-60	60

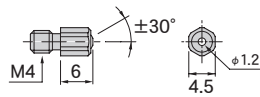

Std. Access.

- Tightening wrench

Note

- Four nozzles are required on the flush type master holder.

Cleaning tool for a spindle taper hole, STAR DUST

☛ P.226



Retention knob with hole

There is no need to remove a retention knob with 6mm coolant-through hole when tightening or loosening SLIMLINE collet.



Feature

Shrink-fit Heater

MONO 3°
MONO CURVE

MONO Series

2PIECE type

UNO

HYPER
version

STRAIGHT
arbor

OTHERS

PERIPHERALS

Technical
Information

SLIMLINE collet 12 type

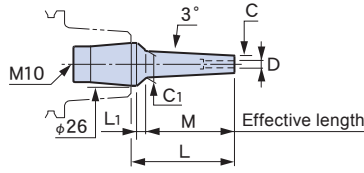
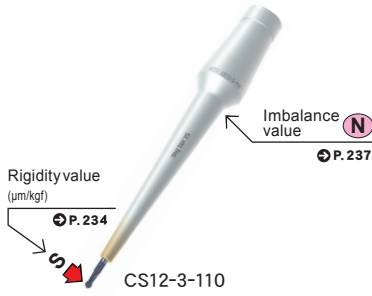





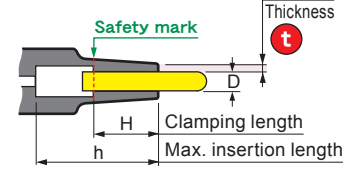













Note
 S refers to the deflection value of an BT40-SLK12-45 and the SLIMLINE collet 12 type combination. The values below are comparable for any shank combination.

Caution
 Setting cutters... Be sure to insert the tool beyond the safety mark.



CODE	φD	φC	t	L	M	L ₁	φC ₁	H	S	(N)	Kg lbs	h		
CS12 -3 - 35	3	6	1.5	35	22	9.5	8.4	10	4.8	0.5	0.2	60		
				55	42		10.5		9.5			80		
				80	67		13.1		15			0.7	105	
				110	97		16.2		20.6			0.8	135	
CR12 -3 - 35	3	7.5	2.25	35	22	9.5	9.9	10	2.9	0.5	0.2	60		
				55	42		12		5.5			80		
				80	67		14.6		8.9			0.7	105	
CF12 -3 - 35	3	9.5	3.25	35	22	9.5	11.9	10	1.9	0.5	0.2	60		
				55	42		14		3.3			0.6	80	
				80	67		16.6		5.3			0.8	105	
CS12 -3.175- 35	3.175	6.175	1.5	35	22	9.5	8.5	10	4.6	0.5	0.2	60		
				55	42		10.6		9			80		
				80	67		13.2		14.3			0.7	105	
				110	97		16.4		19.7			0.8	135	
CS12 -1/8 - 35	1/8	.24	.059	1.38	.87	.37	.33	.39	4.4	0.5	0.35	2.36		
				2.17	1.65		.42		8.7			0.6	0.37	3.15
				3.15	2.64		.52		14			0.7	0.42	4.13
				4.33	3.82		.64		19.3			0.9	0.49	5.31
CR12 -1/8 - 35	1/8	.36	.118	1.38	.87	.37	.45	.39	2	0.5	0.37	2.36		
				2.17	1.65		.53		3.5			0.6	0.42	3.15
				3.15	2.64		.64		5.7			0.8	0.49	4.13
CF12 -1/8 - 35	1/8	.38	.128	1.38	.87	.37	.47	.39	1.8	0.6	0.40	2.36		
				2.17	1.65		.55		3.1			0.7	0.42	3.15
				3.15	2.64		.66		5.1			0.9	0.49	4.13
CS12 -4 - 35	4	7	1.5	35	22	9.5	9.4	12	3.8	0.5	0.2	60		
				55	42		11.5		7.5			80		
				80	67		14.1		11.9			0.7	105	
				110	97		17.2		16.6			0.9	135	
CR12 -4 - 35	4	10	3	35	22	9.5	12.4	12	1.7	0.5	0.2	60		
				55	42		14.5		3.1			0.6	80	
				80	67		17.1		5.1			0.8	105	
CF12 -4 - 35	4	12	4	35	22	9.5	14.4	12	1.3	0.6	0.2	60		
				55	42		16.5		2.2			0.8	80	
				80	67		19.1		3.4			0.9	105	
CS12 -3/16 - 35	3/16	.31	.059	1.38	.87	.37	.40	.59	3.1	0.6	0.35	2.36		
				2.17	1.65		.48		6.2			0.7	0.37	3.15
				3.15	2.64		.58		10.3			0.8	0.42	4.13
				4.33	3.82		.71		14.2			1	0.53	5.31
CR12 -3/16 - 35	3/16	.42	.118	1.38	.87	.37	.51	.59	1.5	0.6	0.37	2.36		
				2.17	1.65		.60		2.7			0.7	0.42	3.15
				3.15	2.64		.70		4.5			0.9	0.51	4.13
CF12 -3/16 - 35	3/16	.50	.157	1.38	.87	.37	.59	.59	1.2	0.7	0.40	2.36		
				2.17	1.65		.68		1.9			0.8	0.46	3.15
				3.15	2.64		.78		3.1			1	0.55	4.13

CODE	ϕD	ϕC	t	L	M	L ₁	ϕC_1	H	S	N	 Kg lbs	h			
CS12 -5 -35	5	8	1.5	35	22	9.5	10.4	15		0.5	0.2	60			
				55	42		12.5					6	0.6	80	
				80	67		15.1					9.7	0.8	105	
				110	97		18.2					13.6	1	135	
CS12 -6 -35	6	9	1.5	35	22	9.5	11.4	18		0.5	0.2	60			
				55	42		13.5					4.9	0.7	80	
				80	67		16.1					8	0.8	105	
				110	97		19.2					11.4	1	135	
CR12 -6 -35	6	12	3	35	22	9.5	14.4	18		0.6	0.2	60			
				55	42		16.5					2.4	0.7	80	
				80	67		19.1					3.9	0.9	105	
CRB12-6 -35	6	14	4	35	22	9.5	16.3	18		0.7	0.2	60			
				55	42		18.0					1.7	0.8	80	
				80	67		21.0					2.7	1	0.3	105
CF12 -6 -35	6	14	4	35	22	9.5	16.4	18		0.7	0.2	60			
				55	42		18.5					1.7	0.9	80	
				80	67		21.1					2.7		0.3	105
CS12 -1/4 -35	1/4	.37	.059	1.38	.87	.37	.46	.71		0.6	0.35	2.36			
				2.17	1.65		.54					4.5	0.7	0.40	3.15
				3.15	2.64		.64					7.4	0.9	0.46	4.13
				4.33	3.82		.77					10.5	1.1	0.57	5.31
CR12 -1/4 -35	1/4	.49	.118	1.38	.87	.37	.58	.71		0.6	0.40	2.36			
				2.17	1.65		.66					2.2	0.8	0.44	3.15
				3.15	2.64		.76					3.7	1	0.55	4.13
CRB12-1/4 -35	1/4	.56	.157	1.38	.87	.37	.66	.71		0.7	0.40	2.36			
				2.17	1.65		.74					1.6	0.8	0.47	3.15
				3.15	2.64		.84					2.6	1.0	0.59	4.13
CF12 -1/4 -35	1/4	.56	.157	1.38	.87	.37	.66	.71		0.8	0.42	2.36			
				2.17	1.65		.74					1.9	0.9	0.49	3.15
				3.15	2.64		.84					2.6	1.1	0.60	4.13
CS12 -7 -35	7	10	1.5	35	22	9.5	12.4	20		0.6	0.2	60			
				55	42		14.5					4.1	0.7	80	
				80	67		17.1					6.8	0.9	105	
				110	97		20.2					9.7	1.2	0.3	135
CS12 -5/16 -35	5/16	.43	.059	1.38	.87	.37	.52	.98		0.6	0.37	2.36			
				2.17	1.65		.60					3.3	0.8	0.40	3.15
				3.15	2.64		.71					5.6	1	0.49	4.13
				4.33	3.82		.83					8.1	1.2	0.62	5.31
CR12 -5/16 -35	5/16	.55	.118	1.38	.87	.37	.64	.98		0.7	0.40	2.36			
				2.17	1.65		.72					1.9	0.8	0.46	3.15
				3.15	2.64		.83					3.1	1	0.57	4.13
CRB12-5/16 -35	5/16	.71	.197	1.38	.87	.37	.80	.98		0.7	0.43	2.36			
				2.17	1.65		.88					1.2	0.9	0.54	3.15
				3.15	—		1.00					1.8		0.72	4.13
CF12 -5/16 -35	5/16	.55	.118	1.38	.87	.37	.64	.98		0.7	0.40	2.36			
				2.17	1.65		.72					1.9	0.8	0.46	3.15
				3.15	2.64		.83					3.1	1	0.57	4.13
CR12 -8 -35	8	14	3	35	22	9.5	16.4	25		0.6	0.2	60			
				55	42		18.5					1.9	0.8	80	
				80	67		21.1					3.1	1	0.3	105
CRB12-8 -35	8	18	5	35	22	9.5	20.3	25		0.7	0.7	60			
				55	42		6.5					22.4	1.1	0.9	80
				80	—		—					—	1.8		0.3
CF12 -8 -35	8	16	4	35	22	9.5	18.4	25		0.8	0.2	60			
				55	42		20.5					1.4	1	80	
				80	67		23.1					2.3	1.2	0.3	105
CS12 -9 -35	9	12	1.5	35	22	9.5	14.4	30		0.7	0.2	60			
				55	42		16.5					2.9	0.9		
				80	67		19.1					4.8	1.1		
				110	97		22.2					7.1	1.3	0.3	

NEW

NEW

NEW

NEW

Feature
Shrink-fit Heater
MONO 3°
MONO CURVE
MONO Series
2PIECE type
UNO
HYPER version
STRAIGHT arbor
OTHERS
PERIPHERALS
Technical Information

Feature	Shrink-fit Heater	MONO 3° MONO CURVE	MONO Series	2PIECE type	UNO	HYPER version	STRAIGHT arbor	OTHERS	PERIPHERALS	Technical Information						
CODE	φD	φC	t	L	M	L ₁	φC ₁	H	S	N	 Kg lbs	h				
CS12 - 3/8 - 35	3/8	.49	.059	1.38	.87	.37	.58	1.18	1.3	0.7	0.35	2.36				
- 55				2.17	1.65		.67									
- 80				3.15	2.64		.77									
- 110				4.33	3.82		.89									
CR12 - 3/8 - 35	3/8	.61	.118	1.38	.87	.37	.70	1.18	0.9	0.7	0.40	2.36				
- 55				2.17	1.65		.78									
- 80				3.15	2.64		.89									
CRB12 - 3/8 - 35	3/8	.85	.236	1.38	.87	.37	.94	1.18	0.6	0.9	0.47	2.36				
- 55				2.17	—		1.00						0.9	0.8	0.62	
- 80				3.15	—		—						1.5	1.1	0.82	
CF12 - 3/8 - 35	3/8	.69	.157	1.38	.87	.37	.78	1.18	0.8	0.9	0.42	2.36				
- 55				2.17	1.65		.86						1.3	1.1	0.53	
- 80				3.15	2.64		.97						2	1.3	0.68	
CS12 - 10 - 35	10	13	1.5	35	22	9.5	15.4	30	1.3	0.8	0.2	60				
- 55				55	42		17.5						2.5	0.9		
- 80				80	67		20.1						4.3	1.1		
- 110				110	97		23.2						6.2	1.4	0.3	
CR12 - 10 - 35	10	16	3	35	22	9.5	18.4	30	0.9	0.7	0.2	60				
- 55				55	42		20.5						1.6	0.9		
- 80				80	67		23.1						2.6	1.1	0.3	
CRB12 - 10 - 35	10	22	6	35	22	9.5	24.3	30	0.6	0.9	0.2	60				
- 55				55	—		25.5						0.9	—	0.3	
- 80				80	—		—						1.5	1.1	0.4	
CF12 - 10 - 35	10	18	4	35	22	9.5	20.4	30	0.7	0.9	0.2	60				
- 55				55	42		22.5						1.1	1.1		
- 80				80	—		—						1.9	1	0.3	
CS12 - 11 - 35	11	14	1.5	35	22	9.5	16.4	30	1.1	0.9	0.2	60				
- 55				55	42		18.5						2.3	1		
- 80				80	67		21.1						3.8	1.3		
- 110				110	97		24.2						5.6	1.5	0.3	
CS12 - 12 - 35	12	15	1.5	35	22	9.5	17.4	30	1	1	0.2	60				
- 55				55	42		19.5						2.1	1.1		
- 80				80	67		22.1						3.5	1.4		
- 110				110	—		—						5	1.3	0.3	
CR12 - 12 - 35	12	20	4	35	22	9.5	22.4	30	0.7	0.9	0.2	60				
- 55				55	42		24.5						1.1	1.1		
- 80				80	—		25.5						1.9	1	0.3	
CF12 - 12 - 35	12	20	4	35	22	9.5	22.4	30	0.7	1	0.2	60				
- 55				55	42		24.5						1.1	1.2		
- 80				80	—		—						1.9	1.1	0.3	
CS12 - 1/2 - 35	1/2	.62	.059	1.38	.87	.37	.71	1.18	0.9	0.9	0.33	2.36				
- 55				2.17	1.65		.79						1.9	1.1	0.42	
- 80				3.15	2.64		.89						3.1	1.3	0.55	
- 110				4.33	3.68		.50						1	4.8	1.7	0.77
CR12 - 1/2 - 35	1/2	.81	.157	1.38	.87	.37	.91	1.18	0.6	1	0.42	2.36				
- 55				2.17	1.99		—						—	1.1	0.9	0.55
- 80				3.15	1.80		1.20						1	1.8	2.2	0.75
CF12 - 1/2 - 35	1/2	.81	.157	1.38	.87	.37	.91	1.18	0.6	1.1	0.40	2.36				
- 55				2.17	1.99		—						—	1.1	1	0.55
- 80				3.15	1.80		1.20						1	1.8	2.3	0.75

Holder stand

Stands for SLIMLINE collets, STRAIGHT arbor and compact holders (HSK-E25, E32). Selectable from four colors. Convenient to make arrangements by color-coding, etc.

CODE	Colors	Front face	Back face	Storage capacity
SDKT-RE	RED	SLIMLINE collet STRAIGHT arbor	Small shank holders (HSK-E25/E32)	25 pieces each
-BL	BLUE			
-GR	GREEN			
-GD	GOLD			



Size : 190 × 190 [mm]

Front face

Back face

UNO

■ Ideal for ultra-high-speed and high-precision machining centers.
Especially suitable for small and micro cutting tools.

Submicron holder

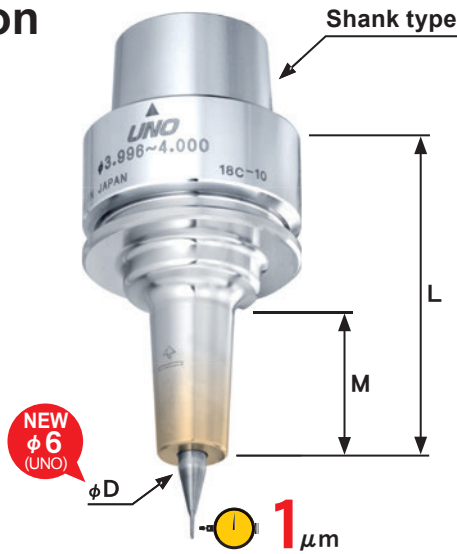

E32 - SL RA 3 - 50 - M22 U

Shank type SLIMLINE φD L Effective length

U : UNO
BU : BLACK UNO

UNO	E25
	E32
	E40
	E50
	F63
BLACK UNO	E25
	E32

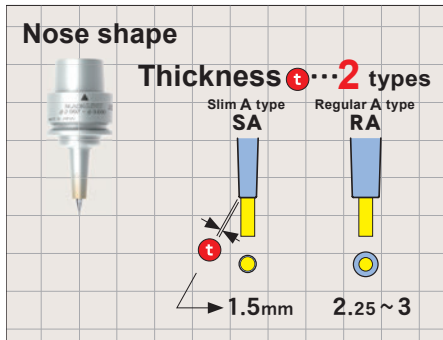

Required cutter shank tolerance



- φD = h4 tolerance
- Roundness = 0.3μm
- Cylindricity = 0.5μm

Recommended cutting tools



Run-out accuracy

A tool run-out accuracy of 1/3 of the cutting feed rate is necessary.

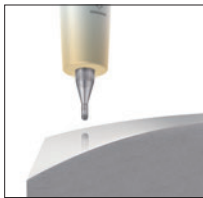

The tool run-out accuracy should be less than **1.5 micron** when you do finishing with a cutting feed rate of 5 microns.

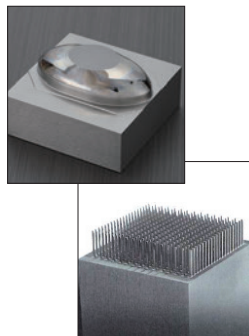

Tool life

Number of machined small-diameter holes (Holes)

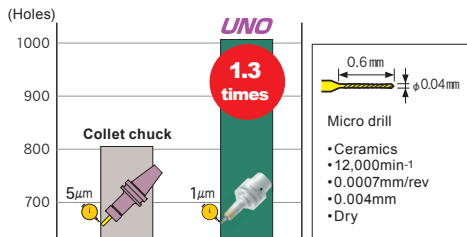

Positioning accuracy

Dispersion of run-out of drill and hole positioning accuracy (μm)

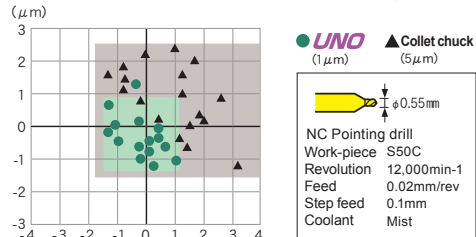

Eye-mark (▲) at the highest run-out direction.

Delivered with the accuracy inspection sheet.



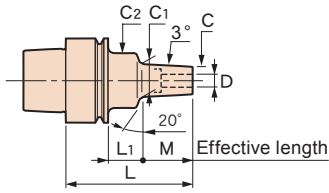
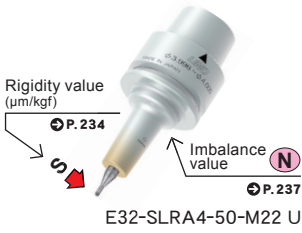

■ **Option**

- 3S Balloon (BLG)

■ **Note**

- SLIMLINE UNO is available for other shank designs and internal bore sizes not listed in this chart. For more information, please contact us.

■ **Caution**

- HSK-E and F shank don't come with a coolant duct and cannot be attached. Consult us if you need it.
- Setting cutters... Be sure to insert the tool beyond the Safety mark.

CODE	φD	φC	t	L	M	L1	φC1	φC2	H	h	Kg	N	S			
E25-SLRA3-35 U	3	7.5	2.25	35	17	8	9.3	18	9	29	0.05	0.37	2.3			
-SLRA4-35 U	4	10	3				11.8		12					0.06	0.38	1.4
NEW -SLRA6-35 U	6	12					13.8		18					0.07	0.39	1.1
-SLSA3.175-35 U	3.175	6.175	1.5				8		9					0.05	0.37	3.5
E32-SLRA3-50-M22 U	3	7.5	2.25	50	22	8	9.8	20	9	42	0.14	0.4	2.8			
-SLRA4-50-M22 U	4	10	3				12.3		12					0.15		1.7
NEW -SLRA6-50-M22 U	6	12					14.3		26					0.2	0.5	1.2
-SLSA3.175-50-M22 U	3.175	6.175	1.5				8.5		20					0.14	0.4	4.4
E40-SLRA3-50-M22 U	3	7.5	2.25	50	22	8	9.8	20	9	42	0.2	0.7	2.8			
-SLRA4-50-M22 U	4	10	3				12.3		12							1.6
NEW -SLRA6-50-M22 U	6	12					14.3		26					18	39	1.2
-SLSA3.175-50-M22 U	3.175	6.175	1.5				8.5		20					9	42	4.4
E50-SLRA3-75-M22 U	3	7.5	2.25	75	22	27	9.8	25	9	65	0.5	1.7	2.8			
-SLRA4-75-M22 U	4	10	3				12.3		12							1.7
F63-SLRA3-75-M22 U	3	7.5	2.25	75	22	27	9.8	25	9	54	0.7	1.8	2.8			
-SLRA4-75-M22 U	4	10	3				12.3		12					58		1.7

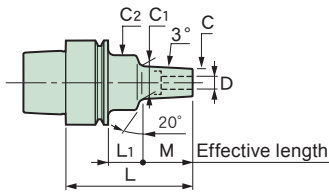
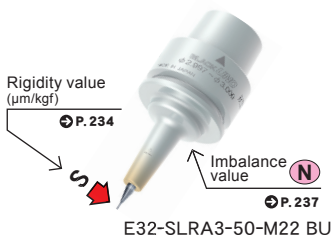

■ **Std. Access.**

- 3S Balloon (BLB)

■ **Caution**

- HSK-E shank doesn't come with a coolant duct and cannot be attached. Consult us if you need it.
- Setting cutters... Be sure to insert the tool beyond the Safety mark.

CODE	φD	φC	t	L	M	L1	φC1	φC2	H	h	Kg	N	S			
E25-SLRA3-35 BU	3	7.5	2.25	35	17	8	9.3	18	9	29	0.05	0.37	2.3			
-SLRA4-35 BU	4	10	3				11.8		12					0.06	0.38	1.4
-SLSA3.175-35 BU	3.175	6.175	1.5				8		9					0.05	0.37	3.5
E32-SLRA3-50-M22 BU	3	7.5	2.25				50		22					8	9.8	20
-SLRA4-50-M22 BU	4	10	3	12.3	12	0.15				1.7						
-SLSA3.175-50-M22 BU	3.175	6.175	1.5	8.5	20	9		42		4.4						

■ **3S Balloon**

Prevents dirt from getting into the Heat shrink internal bore.

BLACK UNO (Black)

CODE	φd
BLB3	3
3.175	3.175
4	4
6	6

UNO (Gray)

CODE	φd
BLG3	3
3.175	3.175
4	4
6	6

It comes with the BLACK UNO as a standard accessory.



■ **Cleaning tool for a spindle taper hole, STAR DUST**

P.226



■ **Holder stand**

P.16



HYPER VERSION

■ A heavy-duty end-mill holder that maximizes machine capability

S For high-speed spindles
Short type

Reduced spindle load and lowered cutting vibration



Higher efficiency + Reduced spindle load

Machining efficiency 2 times
(Compared to conventional holders)

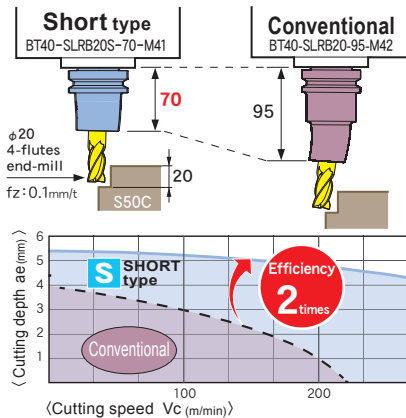

H For rigid-design spindles
Heavy-duty type

Higher clamping force prevents the cutter from pulling out or slipping.

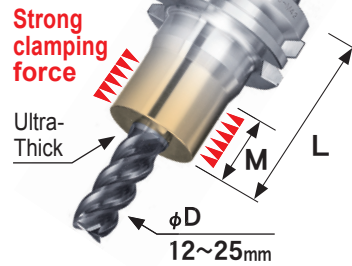

Increased gripping surface pressure × Wider gripping area

High gripping force 1.4 times
(Compared to conventional holders)

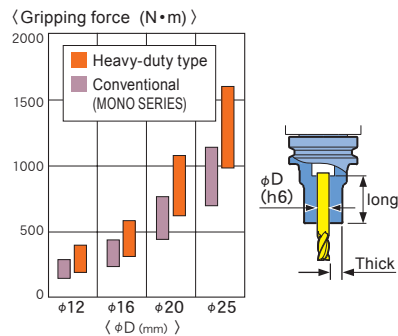

ANTI-SLIPPAGE, SHRINK-FIT HOLDER
SLIMLINE Z PAT.

Z shank prevents the cutter from pulling out or slipping.



Anti-slippage configuration × Anti-pulling out configuration

For efficiency of difficult-to-machine material processing.

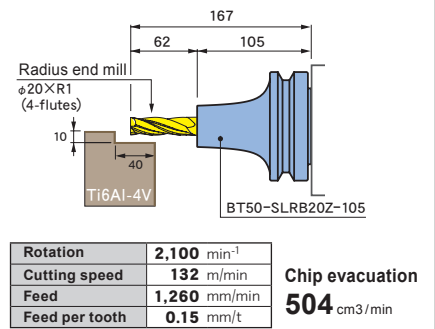

BT40-SLRB20S-60-M42

Shank type SLIMLINE φD HYPER version L Effective length (Short type, Heavy-duty type)

PAGE		Inch	
200	S Short type	BT30	—
		BT40	—
		A63	—
		F80PD	—
201	H Heavy-duty type	BT40	—
		BT50	—
		A63	—
		A100	—
202	Z SLIMLINE Z	BT40	—
		BT50	—
		A63	○
		A100	○
		DN40	—
		DN50	—
		CT40	○
CT50	○		

S: Short type
H: Heavy-duty type
Z: SLIMLINE Z

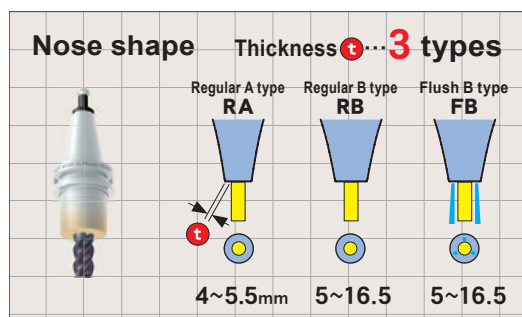

Coolant-through

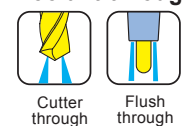

Short type

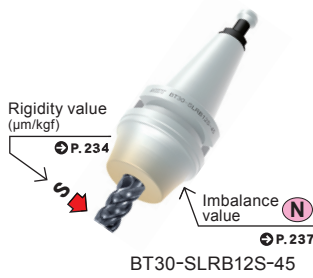

Fig. 1

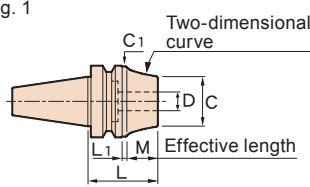

Fig. 2

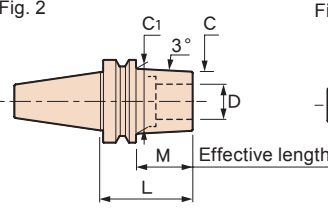

Fig. 3

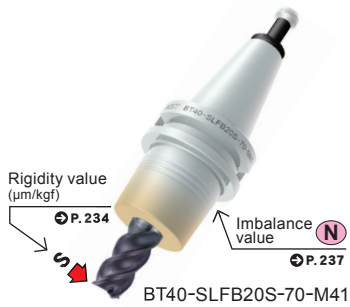
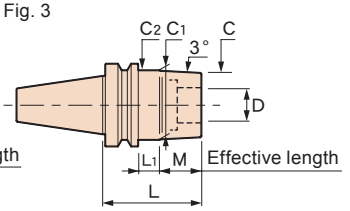

Fig. 4

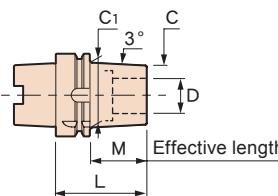
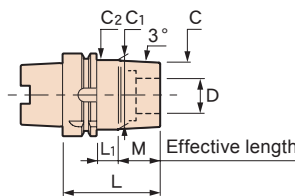
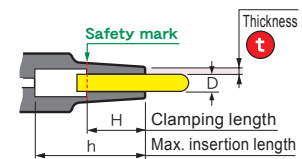

Fig. 5



- **Option**
 - Retention knob (BT)→P.216
- **Std. Access.**
 - Coolant duct (fixed type), (HSK-A63)→P.218
- **Note**
 - Swing type coolant ducts are available upon request(HSK-A63).→P.218
- **Caution**
 - Retention knob...Use a retention knob with hole, or remove the retention knob and heat it.(BT)
 - Setting cutters...Be sure to insert the tool beyond the Safety mark.
 - As for MST SLIMLINE, please use HEAT ROBO DENJI 5000S (HRD-02SH) or HEAT ROBO Baby3000S (HRB-03S).
 - For HEAT ROBO DENJI 5000 (HRD-02SH), please prepare coil No.6 (HRD2-CL6).
 - Remove the coolant duct before heating the holder when you use the hot air heater. (HSK-A)



Thickness

CODE	Fig.	φD	φC	t	L	M	L1	φC1	φC2	H	h	Kg	N	S						
BT30-SLRB10S-45	1	10	28	9	45	20	3	45	—	21	68	0.5	1.0	0.4						
-SLRB12S-45		12	32	10							61		1.2	0.3						
-SLRB16S-45		16	38	11							57		1.5							
BT40-SLRB12S-60-M28	2	12	32	10	60	28	—	35	—	27	95	1.1	1.9	0.3						
-SLFB12S-60-M28		16	38	11							65		33		41.5	30	85	1.2	2.8	
-SLRB16S-65-M33		20	45	12.5							70		41		49.4	36	100	1.3	4.1	0.2
-SLFB20S-70-M41																				
-SLRB25S-75-M30	3	25	49	12	75	30	18	52.2	53	42		1.4	5.4							
-SLFB25S-75-M30																				
A63 -SLRB12S-60-M29	4	12	32	10	60	29	—	35.1	—	27	35	0.8	8.3	0.3						
-SLFB12S-60-M29		16	38	11							65		34		41.6	30	40	1	9.2	
-SLRB16S-65-M34		20	45	12.5							70		42		49.5	36	45	1.1	10.4	0.2
-SLFB20S-70-M42																				
-SLRB25S-75-M30	5	25	49	12	75	30	19	52.2	53	42	50	1.3	11.6							
-SLFB25S-75-M30																				



Cutting tool insertion length

Since the Short type has the shortest gauge length, the cutter insertion length (h) is not deep. Cut off the unnecessary portion of the tool shank and use a cutting tool with the optimal projection. Pay special attention for HSK-A63 shank products.

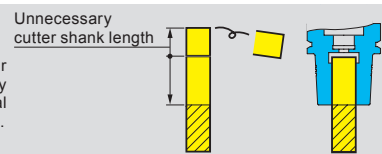

Recommended cutting tools

OSG	DIJET INDUSTRIAL	Tungaloy	MITSUBISHI MATERIALS	MOLDINO
WX-PHSS General purpose	DV-OCSAR For difficult-to-machine materials	SEF4000 For difficult-to-machine materials	C-3SA For aluminum alloy	EPSMS-PN General purpose
UP-PHS General purpose	AL-SEESS For aluminum alloy	SEE4000-A For aluminum alloy	VF-6MHV For difficult-to-machine materials	EPPS For general steel

Heavy-duty type

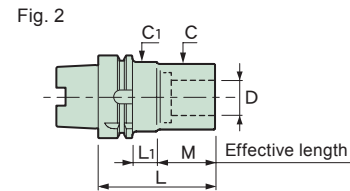
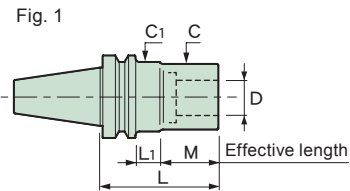
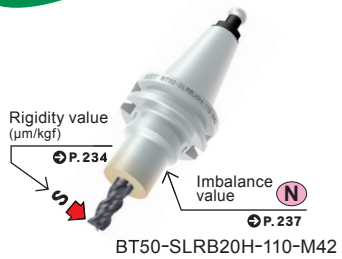

- **Option**
 - Retention knob (BT)→P.216
- **Std. Access.**
 - Coolant duct (fixed type),(HSK-A)→P.218
- **Note**
 - Swing type coolant ducts are available upon request.→P.218
- **Caution**
 - Retention knob...Use a retention knob with hole, or remove the retention knob and heat it.(BT)
 - Setting cutters...Be sure to insert the tool beyond the safety mark.
 - As for MST SLIMLINE, please use HEAT ROBO DENJI 5000S (HRD-02SH) or HEAT ROBO Baby 3000S (HRB-03S).
 - Refer to the table to choose an appropriate heating coil for Heat Robo Denji 5000 (HRD-02SH).
 - Remove the coolant duct before heating the holder when you use hot air heater (HSK-A).
 - For HEAT ROBO Baby 3000S (HRB-03S), dia 70mm nozzle(HRB-NZL70) is required.

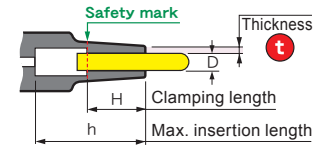

An appropriate heating coil for HRD-02SH

CODE	Fig.	φD	φC	t	L	M	L ₁	φC ₁	H	h	Kg	N	S		
BT40-SLRB12H- 80-M32	1	12	36	12	80	32	21	53	35	115	1.3	5.1	0.3	6	
-SLFB12H- 80-M32															
-SLRB16H- 80-M32			16	42	13					37	90		5.4		
-SLFB16H- 80-M32															
-SLRB20H- 90-M42			20	50	15	90	42			47	100	1.6	6.3	7	
-SLFB20H- 90-M42															
-SLRB25H- 95-M42			25	51	13	95		26		50	105		7		
-SLFB25H- 95-M42															
BT50-SLRB12H- 95-M32	1	12	36	12	95	32	25	53	35	150	3.8	8.8	0.3	6	
-SLFB12H- 95-M32															
-SLRB16H- 95-M32			16	42	13					37		3.9	9		
-SLFB16H- 95-M32															
-SLRB20H-110-M42			20	50	15	110	42	30	63	47	165	4	14.1	0.2	7
-SLFB20H-110-M42															
-SLRB25H-110-M42			25	58	16.5					52		4.2	14.4		
-SLFB25H-110-M42															
A63 -SLRB12H- 80-M32	2	12	36	12	80	32	22	53	35	55	1.1	11.3	0.3	6	
-SLFB12H- 80-M32															
-SLRB16H- 80-M32			16	42	13					37		1.2	11.6		
-SLFB16H- 80-M32															
-SLRB20H- 90-M42			20	50	15	90	42			47	65	1.5	13.1	7	
-SLFB20H- 90-M42															
-SLRB25H- 95-M42			25	51	13	95		27		50	70		14.1		
-SLFB25H- 95-M42															
A100-SLRB12H- 95-M32	2	12	36	12	95	32	34	53	35	63	2.7	26.9	0.3	6	
-SLFB12H- 95-M32															
-SLRB16H- 95-M32			16	42	13					37			27.2		
-SLFB16H- 95-M32															
-SLRB20H-110-M42			20	50	15	110	42	39	63	47	78	3.2	31.3	0.2	7
-SLFB20H-110-M42															
-SLRB25H-110-M42			25	58	16.5					52		3.4	31.8		
-SLFB25H-110-M42									50						

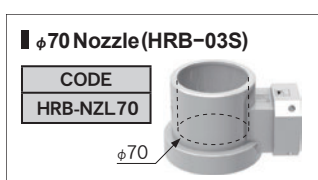

Feature
Shrink-fit Heater
MONO 3° MONO CURVE
MONO Series
2PIECE type
UNO
HYPER version
STRAIGHT arbor
OTHERS
PERIPHERALS
Technical Information

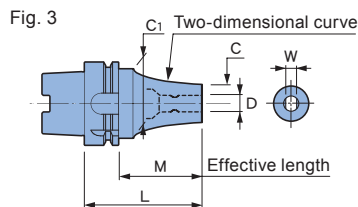
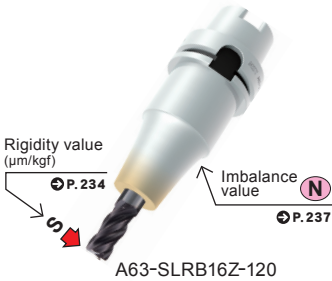
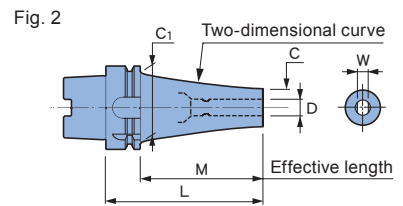
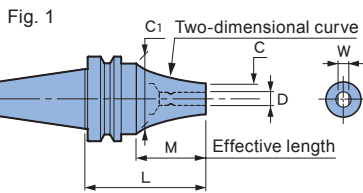

■Option

- The Z-shank (dedicated) tool is needed. Please see below.
- Retention knob(BT)→P.216

■Std. Access.

- Coolant duct(fixed type), (HSK-A)→P.218

■Caution

- Retention knob...Use a retention knob with a hole, or remove the retention knob and heat it (BT).
- Setting cutters...Be sure to insert the tool beyond the safety mark.
- As for MST SLIMLINE, please use HEAT ROBO DENJI 5000S (HRD-02SH) or HEAT ROBO Baby 3000S (HRB-03S).
- Refer to the table to choose an appropriate heating coil for HEAT ROBO DENJI 5000 (HRD-02SH).
- Remove the coolant duct before heating the holder when you use the hot air heater (HSK-A).
- Swing type coolant ducts are available upon request(HSK-A).

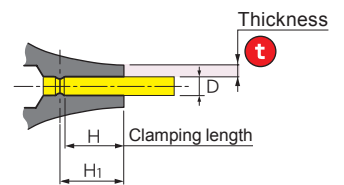

Z shank tool dimensions table

Z Shank is easy to fabricate — the open standards make it possible for anyone to fabricate block shanks.

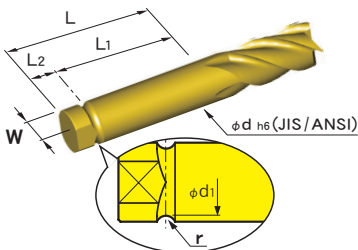

They can provide a tool for SLIMLINE Z



※For additional processing of Z Shanks, please contact us.

Metric

φd (h6)	W	φd ₁	L		L ₁	L ₂		r
			min.	Max.		min.	Max.	
8	6.5	6.5	36	45	29	7	16	2
10	8.5	8.5	42	51	35			
12	10	10						
16	14	14	45	54	38			
20	17	17	53	62	46			
25	22	22	60	69	53			2.5

Inch

φd (h6)	W	φd ₁	L		L ₁	L ₂		r
			min.	max.		min.	max.	
5/16"	.25	.25	1.38	1.75	1.13	.25	.63	.08
3/8"	.32	.32	1.63	2.00	1.38			
1/2"	.42	.42						
5/8"	.55	.55	1.75	2.13	1.50			
3/4"	.63	.63	2.00	2.38	1.75			
1"	.88	.88	2.41	2.75	2.13	.28		.1

An appropriate heating coil for HRD-02SH

Thickness

CODE	Fig.	φD	φC	t	L	M	φC1	H	H _i	W	Kg	N	S	
BT40-SLRB 8Z- 90	1	8	18	5	90	52	53	24	29	6.5	1.2	4.6	0.6	2
120					1.6						6.8	0.7		
150					2						8.9	0.8		
180					2.4						11	0.9		
-SLFB 8Z- 90	1	8	18	5	90	52	53	24	29	6.5	1.2	4.6	0.6	2
120					1.6						6.8	0.7		
150					2						8.9	0.8		
180					2.4						11	0.9		
BT40-SLRB10Z- 90	1	10	22	6	90	52	53	30	35	8.5	1.3	4.8	0.5	3
120					1.7						6.9	0.6		
150					2						9	0.7		
180					2.4						11.1	0.8		
-SLFB10Z- 90	1	10	22	6	90	52	53	30	35	8.5	1.3	4.8	0.5	3
120					1.7						6.9	0.6		
150					2						9	0.7		
180					2.4						11.1	0.8		
BT40-SLRB12Z- 90	1	12	26	7	90	52	53	30	35	10	1.3	5	0.4	3
120					1.7						7.1	0.5		
150					2.1						9.2	0.6		
180					2.5						11.3	0.8		
-SLFB12Z- 90	1	12	26	7	90	52	53	30	35	10	1.3	5	0.4	3
120					1.7						7.1	0.5		
150					2.1						9.2	0.6		
180					2.5						11.3	0.8		
BT40-SLRB16Z- 90	1	16	32	8	90	52	53	32	38	14	1.4	5.3	0.4	3
120					1.7						7.5	0.5		
150					2.1						9.6	0.6		
-SLFB16Z- 90	1	16	32	8	90	52	53	32	38	14	1.4	5.3	0.4	3
120					1.7						7.5	0.5		
150					2.1						9.6	0.6		
BT40-SLRB20Z- 90	1	20	38	9	90	42	53	40	46	17	1.5	5.9	0.3	4
120					1.9						8	0.4		
150					2.3						10.1	0.6		
-SLFB20Z- 90	1	20	38	9	90	42	53	40	46	17	1.5	5.9	0.3	4
120					1.9						8	0.4		
150					2.3						10.1	0.5		
BT40-SLRB25Z- 95	1	25	45	10	95	42	53	45	53	22	1.6	6.7	0.3	4
125					2						8.8	0.4		
-SLFB25Z- 95	1	25	45	10	95	42	53	45	53	22	1.6	6.7	0.3	4
125					2						8.8	0.4		
BT50-SLRA12Z-105	1	12	22	5	105	67	85	30	35	10	3.9	13	0.5	2
135					97	4.5					14.8	0.6		
165					127	5.1					16.1	0.7		
195					157	5.6					18	0.8		
-SLRB12Z-165	1	12	26	7	165	127	85	30	35	10	5.1	17.3	0.6	3
195					157	5.4					18.9	0.7		
-SLFB12Z-165	1	12	26	7	165	127	85	30	35	10	5.1	17.3	0.6	3
195					157	5.4					18.9	0.7		
BT50-SLRA16Z-105	1	16	27	5.5	105	67	85	32	38	14	3.9	13.3	0.4	3
135					97	4.3					15.4	0.5		
165					127	5					17.2	0.6		
195					157	5.3					18.8	0.8		
-SLRB16Z-165	1	16	32	8	165	127	85	32	38	14	5.1	17.5	0.5	3
195					157	5.8					20.3	0.6		
-SLFB16Z-165	1	16	32	8	165	127	85	32	38	14	5.1	17.5	0.5	3
195					157	5.8					20.3	0.7		

BT40

BT50



Feature
Shrink-fit Heater
MONO 3° MONO CURVE
MONO Series
2PIECE type
UNO
HYPER version
STRAIGHT arbor
OTHERS
PERIPHERALS
Technical Information



CODE	Fig.	φD	φC	t	L	M	φC1	H	H1	W	Kg	N	S	
BT50-SLRB20Z-105	1	20	38	9	105	67	85	40	46	17	4.1	13.8	0.3	4
-135					135	97					4.8	17.2		
BT50 -165					165	127					5.5	20.7	0.4	
BT50 -SLFB20Z-105	1	20	38	9	105	67	85	40	46	17	4.1	13.8	0.3	4
-135					135	97					4.8	17.2		
-165					165	127					5.5	20.7	0.4	
BT50-SLRB25Z-110	1	25	45	10	110	72	85	45	53	22	4.3	15	0.3	4
-140					140	102					4.8	17.7		
BT50 -SLFB25Z-110	1	25	45	10	110	72	85	45	53	22	4.3	15	0.3	4
-140					140	102					4.8	17.7		
A63 -SLRA 8Z- 90	2	8	16	4	90	64	53	24	29	6.5	1	8.4	0.7	2
-120					120	94					1.2	9.6	1	
-150					150	124					1.4	10.8	1.4	
A63 -SLRB 8Z- 90	3	8	18	5	90	52	53	24	29	6.5	1.1	10.9	0.6	2
-120					120						1.4	14.1	0.8	
-150					150						1.8	17.2		
-180					180						2.2	20.4	0.9	
A63 -SLFB 8Z- 90	3	8	18	5	90	52	53	24	29	6.5	1.1	10.9	0.6	2
-120					120						1.4	14.1	0.7	
-150					150						1.8	17.2		
-180					180						2.2	20.4	0.9	
A63-SLRA5/16Z- 90	2	5/16	.63	.16	3.54	2.52	2.09	.94	1.13	.25	2.2	8.4	0.7	2
-120					4.72	3.70					2.6	9.6	1	
-150					5.91	4.88					3.1	10.8	1.4	
A63 -SLRB5/16Z- 90	3	5/16	.71	.20	3.54	2.05	2.09	.94	1.13	.25	2.4	10.9	0.6	2
-120					4.72						3.1	14.1	0.7	
-150					5.91						4	17.2		
-180					7.09						4.9	20.4	0.9	
A63 -SLFB5/16Z- 90	3	5/16	.71	.20	3.54	2.05	2.09	.94	1.13	.25	2.4	10.9	0.6	2
-120					4.72						3.1	14.1	0.7	
-150					5.91						4	17.2		
-180					7.09						4.9	20.4	0.9	
A63 -SLRA10Z- 90	2	10	19	4.5	90	64	53	30	35	8.5	1	8.5	0.6	2
-120					120	94					1.2	9.6	0.9	
-150					150	124					1.3	10.9	1.4	
A63 -SLRB10Z- 90	3	10	22	6	90	52	53	30	35	8.5	1.1	11.1	0.5	3
-120					120						1.5	14.3	0.7	
-150					150						1.6	17.4		
-180					180						2.3	20.6	0.8	
A63 -SLFB10Z- 90	3	10	22	6	90	52	53	30	35	8.5	1.1	11.1	0.5	3
-120					120						1.5	14.3	0.6	
-150					150						1.6	17.4		
-180					180						2.3	20.6	0.8	
A63-SLRA3/8Z- 90	2	3/8	.73	.18	3.54	2.52	2.09	1.18	1.38	.31	2.2	8.5	0.6	2
-120					4.72	3.70					2.6	9.6	0.9	
-150					5.91	4.88					2.9	10.9	1.4	
A63 -SLRB3/8Z- 90	3	3/8	.85	.24	3.54	2.05	2.09	1.18	1.38	.31	2.4	11.1	0.5	3
-120					4.72						3.3	14.3	0.6	
-150					5.91						3.5	17.4		
-180					7.09						5.1	20.6	0.8	
A63 -SLFB3/8Z- 90	3	3/8	.85	.24	3.54	2.05	2.09	1.18	1.38	.31	2.4	11.1	0.5	3
-120					4.72						3.3	14.3	0.6	
-150					5.91						3.5	17.4		
-180					7.09						5.1	20.6	0.8	



Feature
Shrink-fit Heater
MONO 3° MONO CURVE
MONO Series
2PIECE type
UNO
HYPER version
STRAIGHT arbor
OTHERS
PERIPHERALS
Technical information



CODE	Fig.	φD	φC	t	L	M	φC1	H	H1	W	Kg	N	S	Feature
A63 -SLRA 12Z- 90	2	12	22	5	90	64	53	30	35	10	1	8.5	0.6	2
-120					120	94					1.3	10.4	0.7	
-150					150	124					1.5	11.7	1.1	
-SLRB 12Z- 90	3	12	26	7	90	52	53	30	35	10	1.1	11.4	0.4	3
-120					120						1.5	14.6	0.5	
-150					150						1.6	17.7	0.6	
-180					180						2.3	20.9	0.7	
-SLFB 12Z- 90	3	12	26	7	90	52	53	30	35	10	1.1	11.4	0.4	3
-120					120						1.5	14.6	0.5	
-150					150						1.6	17.7	0.6	
-180					180						2.3	20.9	0.7	
A63 -SLRA1/2Z- 90	2	1/2	.89	.20	3.54	2.52	2.09	1.18	1.38	.42	2.2	8.5	0.6	2
-120					4.72	3.70					2.9	10.4	0.7	
-150					5.91	4.88					3.3	11.7	1.1	
-SLRB1/2Z- 90	3	1/2	1.05	.28	3.54	2.05	2.09	1.18	1.38	.42	2.4	11.4	0.4	3
-120					4.72						3.3	14.6	0.5	
-150					5.91						3.5	17.7	0.6	
-180					7.09						5.1	20.9	0.7	
-SLFB1/2Z- 90	3	1/2	1.05	.28	3.54	2.05	2.09	1.18	1.38	.42	2.4	11.4	0.4	3
-120					4.72						3.3	14.6	0.5	
-150					5.91						3.5	17.7	0.6	
-180					7.09						5.1	20.9	0.7	
A63 -SLRA 16Z- 90	3	16	27	5.5	90	52	53	32	38	14	1.1	11.6	0.4	3
-120	2				120	94					1.3	12.9	0.7	
-SLRB 16Z- 90	3	16	32	8	90	52	53	32	38	14	1.2	12	0.4	3
-120					120						1.6	15.1		
-150					150						2	18.3	0.6	
-SLFB 16Z- 90	3	16	32	8	90	52	53	32	38	14	1.2	12	0.4	3
-120					120						1.6	15.1		
-150					150						2	18.3	0.6	
A63 -SLRA5/8Z- 90	3	5/8	1.06	.22	3.54	2.05	2.09	1.26	1.5	.55	2.4	11.6	0.4	3
-120	2				4.72	3.70					2.9	12.9	0.7	
-SLRB5/8Z- 90	3	5/8	1.25	.31	3.54	2.05	2.09	1.26	1.5	.55	2.6	12.0	0.4	3
-120					4.72						3.5	15.1		
-150					5.91						4.4	18.3	0.6	
-SLFB5/8Z- 90	3	5/8	1.25	.31	3.54	2.05	2.09	1.26	1.5	.55	2.6	12.0	0.4	3
-120					4.72						3.5	15.1		
-150					5.91						4.4	18.3	0.6	
A63 -SLRB 20Z- 90	3	20	38	9	90	42	53	40	46	17	1.3	12.7	0.3	4
-120					120						1.4	15.9	0.4	
-150					150						2.1	19.1	0.5	
-SLFB 20Z- 90	3	20	38	9	90	42	53	40	46	17	1.3	12.7	0.3	4
-120					120						1.4	15.9	0.4	
-150					150						2.1	19.1	0.5	
A63 -SLRB3/4Z- 90	3	3/4	1.46	.35	3.54	1.65	2.09	1.5	1.75	.63	2.9	12.7	0.3	4
-120					4.72						3.1	15.9	0.4	
-150					5.91						4.6	19.1	0.5	
-SLFB3/4Z- 90	3	3/4	1.46	.35	3.54	1.65	2.09	1.5	1.75	.63	2.9	12.7	0.3	4
-120					4.72						3.1	15.9	0.4	
-150					5.91						4.6	19.1	0.5	
A63 -SLRB 25Z- 95	3	25	45	10	95	42	53	45	53	22	1.4	13.9	0.3	4
-125					125						1.8	17.1	0.4	
-SLFB 25Z- 95	3	25	45	10	95	42	53	45	53	22	1.4	13.9	0.3	4
-125					125						1.8	17.1	0.4	
A63 -SLRB 1Z- 95	3	1"	1.79	.39	3.74	1.65	2.09	1.77	2.09	.88	3.1	13.9	0.3	4
-125					4.92						4	17.1	0.4	
-SLFB 1Z- 95	3	1"	1.79	.39	3.74	1.65	2.09	1.77	2.09	.88	3.1	13.9	0.3	4
-125					4.92						4	17.1	0.4	



Feature
Shrink-fit Heater
MONO 3° MONO CURVE
MONO Series
2PIECE type
UNO
HYPER version
STRAIGHT arbor
OTHERS
PERIPHERALS
Technical Information



CODE	Fig.	φD	φC	t	L	M	φC1	H	H1	W	Kg	N	S	
A100-SLRA 12Z-105	2	12	22	5	105	76	85	30	35	10	3	27.7	0.4	3
-135					135	106					3.3	29.9	0.6	
-165					165	136					3.7	31.3	0.8	2
-195					195	166					4.5	35.6		
-SLRB 12Z-165	2	12	26	7	165	136	85	30	35	10	4	34.3	0.6	3
-195					195	166					4.8	39.2		
-SLFB 12Z-165	2	12	26	7	165	136	85	30	35	10	4	34.3	0.6	3
-195					195	166					4.8	39.2	0.7	
A100-SLRA1/2Z-105	2	1/2	.89	.20	4.13	2.99	3.35	1.18	1.38	.42	6.6	27.7	0.4	3
-135					5.31	4.17					7.3	29.9	0.5	
-165					6.50	5.35					8.2	31.3	0.8	
-195					7.68	6.54					9.9	35.6		
-SLRB1/2Z-165	2	1/2	1.05	.28	6.50	5.35	3.35	1.18	1.38	.42	8.8	34.3	0.6	3
-195					7.68	6.54					10.6	39.2	0.7	
-SLFB1/2Z-165	2	1/2	1.05	.28	6.50	5.35	3.35	1.18	1.38	.42	8.8	34.3	0.6	3
-195					7.68	6.54					10.6	39.2	0.7	
A100-SLRA 16Z-105	2	16	27	5.5	105	76	85	32	38	14	3	28.1	0.4	3
-135					135	106					3.4	30.5	0.5	
-165					165	136					4	34.2	0.6	
-195					195	166					4.3	36.6	0.8	
-SLRB 16Z-165	2	16	32	8	165	136	85	32	38	14	4	34.4	0.5	3
-195					195	166					4.5	37.6	0.6	
-SLFB 16Z-165	2	16	32	8	165	136	85	32	38	14	4	34.4	0.5	3
-195					195	166					4.5	37.6	0.7	
A100-SLRA5/8Z-105	2	5/8	1.06	.22	4.13	2.99	3.35	1.26	1.50	.55	6.6	28.1	0.4	3
-135					5.31	4.17					7.5	30.5	0.5	
-165					6.50	5.35					8.8	34.2	0.6	
-195					7.68	6.54					9.5	36.6		
-SLRB5/8Z-165	2	5/8	1.25	.31	6.50	5.35	3.35	1.26	1.50	.55	8.8	34.4	0.5	3
-195					7.68	6.54					9.9	37.6	0.7	
-SLFB5/8Z-165	2	5/8	1.25	.31	6.50	5.35	3.35	1.26	1.50	.55	8.8	34.4	0.5	3
-195					7.68	6.54					9.9	37.6	0.7	
A100-SLRB 20Z-105	2	20	38	9	105	76	85	40	46	17	3.1	28.7	0.3	4
-135					135	106					3.8	33.4		
-165					165	136					4.6	38.9	0.6	
-SLFB 20Z-105	2	20	38	9	105	76	85	40	46	17	3.1	28.7	0.3	4
-135					135	106					3.8	33.4		
-165					165	136					4.6	38.9	0.4	
A100-SLRB3/4Z-105	2	3/4	1.46	.35	4.13	2.99	3.35	1.50	1.75	.63	6.8	28.7	0.3	4
-135					5.31	4.17					8.4	33.4		
-165					6.50	5.35					10.1	38.9	0.4	
-SLFB3/4Z-105	2	3/4	1.46	.35	4.13	2.99	3.35	1.50	1.75	.63	6.8	28.7	0.3	4
-135					5.31	4.17					8.4	33.4		
-165					6.50	5.35					10.1	38.9	0.4	
A100-SLRB 25Z-110	2	25	45	10	110	81	85	45	53	22	3.1	29.7	0.3	4
-140					140	111					3.8	34.4		
-SLFB 25Z-110	2	25	45	10	110	81	85	45	53	22	3.1	29.7	0.3	4
-140					140	111					3.8	34.4		
A100-SLRB 1Z-110	2	1"	1.79	.39	4.33	3.19	3.35	1.77	2.13	.88	6.8	29.7	0.3	4
-140					5.51	4.37					8.4	34.4		
-SLFB 1Z-110	2	1"	1.79	.39	4.33	3.19	3.35	1.77	2.13	.88	6.8	29.7	0.3	4
-140					5.51	4.37					8.4	34.4		



Feature
Shrink-fit Heater
MONO 3° MONO CURVE
MONO Series
2PIECE type
UNO
HYPER version
STRAIGHT arbor
OTHERS
PERIPHERALS
Technical Information



CODE	Fig.	φD	φC	t	L	M	φC1	H	H ₁	W	Kg	N	S	Feature
DN40AD-SLRB8Z- 90	1	8	18	5	90	52	50	24	29	6.5	1.1	7.8	0.6	2
-120					120		53				1.5	10.9	0.7	
-150					150						1.9	14.1	0.8	
-180					180						2.3	17.3	0.9	
-SLFB8Z- 90	1	8	18	5	90	52	50	24	29	6.5	1.1	7.8	0.6	2
-120					120		53				1.5	10.9	0.7	
-150					150						1.9	14.1	0.8	
-180					180						2.3	17.3	0.9	
DN40AD-SLRB10Z- 90	1	10	22	6	90	52	50	30	35	8.5	1.2	8	0.5	3
-120					120		53				1.6	11.2	0.6	
-150					150						2	14.3	0.7	
-180					180						2.3	17.5	0.9	
-SLFB10Z- 90	1	10	22	6	90	52	50	30	35	8.5	1.2	8	0.5	3
-120					120		53				1.6	11.2	0.6	
-150					150						2	14.3	0.7	
-180					180						2.3	17.5	0.8	
DN40AD-SLRB12Z- 90	1	12	26	7	90	52	50	30	35	10	1.2	8.3	0.5	3
-120					120		53				1.6	11.5	0.5	
-150					150						2	14.6	0.6	
-180					180						2.4	17.8	0.8	
-SLFB12Z- 90	1	12	26	7	90	52	50	30	35	10	1.2	8.3	0.4	3
-120					120		53				1.6	11.5	0.5	
-150					150						2	14.6	0.6	
-180					180						2.4	17.8	0.8	
DN40AD-SLRB16Z- 90	1	16	32	8	90	52	50	32	38	14	1.3	8.8	0.4	3
-120					120		53				1.7	12	0.5	
-150					150						2.1	15.2	0.6	
-SLFB16Z- 90	1	16	32	8	90	52	50	32	38	14	1.3	8.8	0.4	3
-120					120		53				1.7	12	0.5	
-150					150						2.1	15.2	0.6	
DN40AD-SLRB20Z- 90	1	20	38	9	90	42	50	40	46	17	1.4	9.6	0.3	4
-120					120		53				1.8	12.8	0.4	
-150					150						2.2	16	0.6	
-SLFB20Z- 90	1	20	38	9	90	42	50	40	46	17	1.4	9.6	0.3	4
-120					120		53				1.8	12.8	0.4	
-150					150						2.2	16	0.6	
DN50AD-SLRA12Z-105	1	12	22	5	105	70	70	30	35	10	3.5	16.7	0.4	3
-135					135	100					3.9	18.4	0.6	
-165					165	130					4.4	19.4	0.8	2
-195					195	160					4.5	20.6	1.2	
-SLRB12Z-165	1	12	26	7	165	130	70	30	35	10	4.5	22.1	0.6	3
-195					195	160					4.8	24.4	0.8	
-SLFB12Z-165	1	12	26	7	165	130	70	30	35	10	4.5	22.1	0.6	3
-195					195	160					4.8	24.4	0.8	
DN50AD-SLRA16Z-105	1	16	27	5.5	105	70	70	32	38	14	3.5	17	0.4	4
-135					135	100					3.9	18.4	0.5	3
-165					165	130					4.5	22.1	0.7	
-195					195	160					4.8	24.4	0.8	
-SLRB16Z-165	1	16	32	8	165	130	70	32	38	14	4.4	21.8	0.6	3
-195					195	160					5.0	25.5	0.7	
-SLFB16Z-165	1	16	32	8	165	130	70	32	38	14	4.4	21.8	0.6	3
-195					195	160					5.0	25.5	0.7	
DN50AD-SLRB20Z-105	1	20	38	9	105	70	70	40	46	17	3.6	17.6	0.3	4
-135					135	100					4.0	21	0.4	
-165					165	130					4.7	25.4	0.5	
-SLFB20Z-105	1	20	38	9	105	70	70	40	46	17	3.6	17.6	0.3	4
-135					135	100					4.0	21	0.4	
-165					165	130					4.7	25.4	0.5	
DN50AD-SLRB25Z-110	1	25	45	10	110	75	70	45	53	22	3.7	18.8	0.3	4
-140					140	90					4.4	23.4	0.3	
-SLFB25Z-110	1	25	45	10	110	75	70	45	53	22	3.7	18.8	0.3	4
-140					140	90					4.4	23.4	0.4	

DIN



Feature
Shrink-fit Heater
MONO 3° MONO CURVE
MONO Series
2PIECE type
UNO
HYPER Version
STRAIGHT arbor
OTHERS
PERIPHERALS
Technical Information



CODE	Fig.	φD	φC	t	L	M	φC1	H	H1	W	lbs	N	S	
CT40-SLRB5/16Z- 95	1	5/16	.71	.20	3.74	2.05	2.09	.94	1.13	.25	2.6	7.6	0.7	2
-120					4.72						3.3	10.2		
-150					5.91						4.2	13.4	0.8	
-180					7.09						5.1	16.6	1	
-SLFB5/16Z- 95	1	5/16	.71	.20	3.74	2.05	2.09	.94	1.13	.25	2.6	7.6	0.7	2
-120					4.72						3.3	10.2		
-150					5.91						4.2	13.4	0.8	
-180					7.09						5.1	16.6	1	
CT40-SLRB 3/8Z- 95	1	3/8	.85	.24	3.74	2.05	2.09	1.18	1.38	.31	2.6	7.7	0.6	3
-120					4.72						3.3	10.5		
-150					5.91						4.2	13.6	0.8	
-180					7.09						5.1	16.8	0.9	
-SLFB 3/8Z- 95	1	3/8	.85	.24	3.74	2.05	2.09	1.18	1.38	.31	2.6	7.7	0.6	3
-120					4.72						3.3	10.5		
-150					5.91						4.2	13.6	0.8	
-180					7.09						5.1	16.8	0.9	
CT40-SLRB 1/2Z- 95	1	1/2	1.05	.28	3.74	2.05	2.09	1.18	1.38	.42	2.9	8.1	0.5	3
-120					4.72						3.5	10.8	0.6	
-150					5.91						4.4	14	0.7	
-180					7.09						5.3	17.1	0.9	
-SLFB 1/2Z- 95	1	1/2	1.05	.28	3.74	2.05	2.09	1.18	1.38	.42	2.9	8.1	0.5	3
-120					4.72						3.5	10.8	0.6	
-150					5.91						4.4	14	0.7	
-180					7.09						5.3	17.1	0.9	
CT40-SLRB 5/8Z- 95	1	5/8	1.25	.31	3.74	2.05	2.09	1.26	1.5	.55	2.9	8.6	0.4	3
-120					4.72						3.5	11.3	0.5	
-150					5.91						4.4	14.5	0.7	
-SLFB 5/8Z- 95	1	5/8	1.25	.31	3.74	2.05	2.09	1.26	1.5	.55	2.9	8.6	0.4	3
-120					4.72						3.5	11.3	0.5	
-150					5.91						4.4	14.5	0.7	
CT40-SLRB 3/4Z- 95	1	3/4	1.46	.35	3.74	1.65	2.09	1.5	1.75	.63	3.3	9.2	0.4	4
-120					4.72						4	12	0.5	
-150					5.91						4.9	15.1	0.7	
-SLFB 3/4Z- 95	1	3/4	1.46	.35	3.74	1.65	2.09	1.5	1.75	.63	3.3	9.2	0.4	4
-120					4.72						4	12	0.5	
-150					5.91						4.9	15.1	0.7	
CT50-SLRA 1/2Z-105	1	1/2	.89	.20	4.13	2.76	2.76	1.18	1.38	.42	7.7	16.3	0.4	3
-135					5.31	3.94					8.6	18	0.6	
-165					6.50	5.12					9.5	18.9	0.8	2
-195					7.68	6.30					10.6	22.1		
-SLRB 1/2Z-165	1	1/2	1.05	.28	6.50	5.12	2.76	1.18	1.38	.42	9.9	21.7	0.6	3
-195					7.68	6.30					10.6	24	0.8	
-SLFB 1/2Z-165	1	1/2	1.05	.28	6.50	5.12	2.76	1.18	1.38	.42	9.9	21.7	0.6	3
-195					7.68	6.30					10.6	24	0.8	
CT50-SLRA 5/8Z-105	1	5/8	1.06	.22	4.13	2.76	2.76	1.26	1.50	.55	7.7	16.6	0.4	4
-135					5.31	3.94					7.9	18.1	0.5	3
-165					6.50	5.12					9.7	21.7	0.7	
-195					7.68	6.30					10.4	24	0.8	
-SLRB 5/8Z-165	1	5/8	1.25	.31	6.50	5.12	2.76	1.26	1.50	.55	9.7	21.4	0.6	3
-195					7.68	6.30					10.8	25.1	0.7	
-SLFB 5/8Z-165	1	5/8	1.25	.31	6.50	5.12	2.76	1.26	1.50	.55	9.7	21.4	0.6	3
-195					7.68	6.30					10.8	25.1	0.7	
CT50-SLRB 3/4Z-105	1	3/4	1.46	.35	4.13	2.76	2.76	1.50	1.75	.63	7.9	17.2	0.3	4
-135					5.31	3.94					8.8	20.5	0.4	
-165					6.50	5.12					10.4	24.9	0.5	
-SLFB 3/4Z-105	1	3/4	1.46	.35	4.13	2.76	2.76	1.50	1.75	.63	7.9	17.2	0.3	4
-135					5.31	3.94					8.8	20.5	0.4	
-165					6.50	5.12					10.4	24.9	0.5	
CT50-SLRB 1Z -110	1	1"	1.79	.39	4.33	2.95	2.76	1.77	2.13	.88	8.2	18.4	0.3	4
-140					5.51	3.94					9.5	22.7	0.4	
-SLFB 1Z -110	1	1"	1.79	.39	4.33	2.95	2.76	1.77	2.13	.88	8.2	18.4	0.3	4
-140					5.51	3.94					9.5	22.7	0.4	



STRAIGHT arbor

■ Extends accurately the standard cutter.

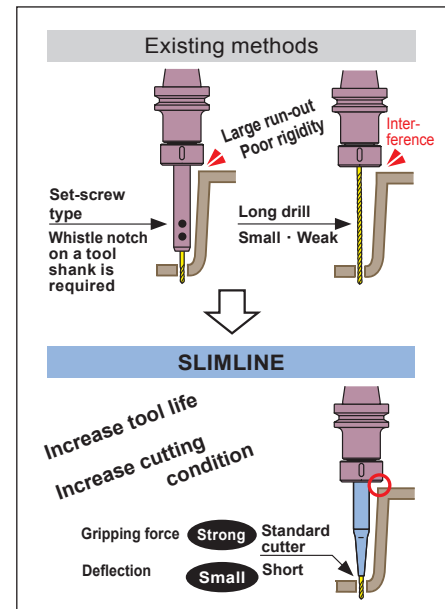
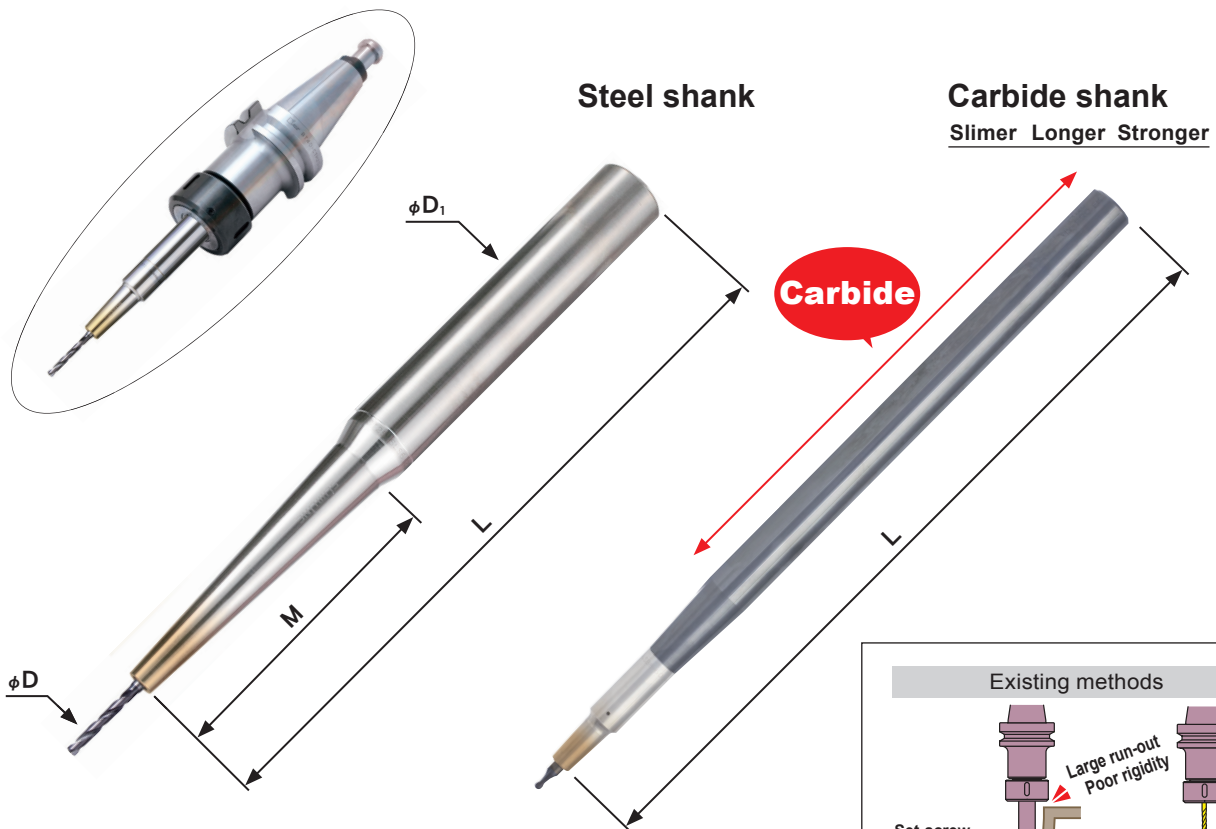

ST 10 C - SL SA 3 - 110 - M42

STRAIGHT arbor φD1 Carbide shank SLIMLINE φD L Effective length

METRIC	10
	12
	16
	20
	25
	32
	42
INCH	19.05
	25.4

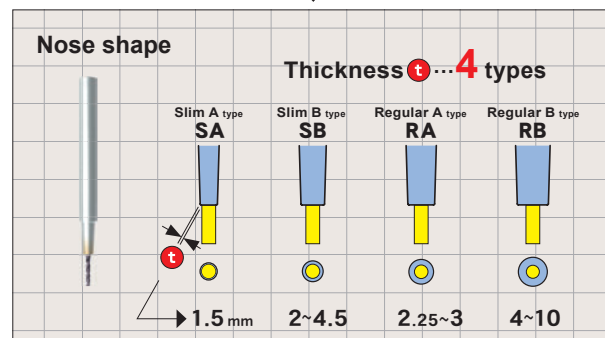

Standard type



ST25-SLRB6-240

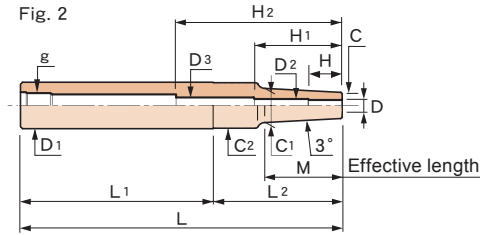
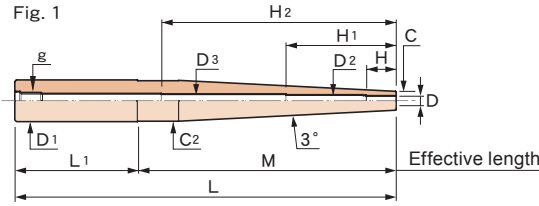



Caution
 ●Setting cutters...Be sure to insert the tool beyond the safety mark.

Compatibility table for HRD-01S

[O] Available [x] Not available

CODE	Fig.	φD	φC	t	L	M	D1	H	L1	L2	φC1	φC2	g	h	Kg lbs	φD2	φD3	H1	H2
ST10-SLSA3- 80-M 35	1	3	6	1.5	80	35	10	9	45	-	-	9.3	M 6	64	0.03	4	-	49.6	-
ST16-SLRA3- 90-M 22	2		7.5	2.25	90	22	16		60	30	9.8	15.5	M10	62	0.09			33.7	
-SLSA3-115-M 42			6	1.5	115	42				55	10.4			87	0.1			53.7	
-SLRA3-115-M 42			7.5	2.25					65	50	11.9								
-SLSA3-140-M 67			6	1.5	140	67			60	80	13			112		6	54.4	84.3	
-SLRA3-140-M 67			7.5	2.25					65	75	14.5								
ST20-SLRA3-175-M 97					175	97	20		70	105	17.7	19.5		147				53.4	109.3
-SLSA3-200-M 97			6	1.5	200				90	110	16.2			172	0.3			54.4	104.3
ST25-SLSA3-245-M 97					245		25		120	125		24.5		217	0.6		5	49.7	105.3
-SLRA3-245-M 97			7.5	2.25							17.7							47.5	99.5
-SLSA3-315-M195	1		6	1.5	315	195				-	-			287				49.7	112.1
-SLRA3-315-M 67	2		7.5	2.25		67			220	95	14.5				0.9				75.3
ST10-SLSA3.175-80-M35	1	3.175	6.175	1.5	80	35	10	10	45	-	-	9.3	M 6	64	0.03	4	-	49.6	-
ST19.05-SLS1/8-200	2	1/8	.24	.059	7.87	3.82	.750	.38	3.54	4.33	.64	.728	M10	7.20	0.62	.16	.24	2.16	4.13
ST10-SLSA4- 80-M 35	1	4	7	1.5	80	35	10	12	45	-	-	9.5	M 6	64	0.03	5	-	50	-
ST16-SLRA4- 90-M 22	2		10	3	90	22	16		60	30	12.3	15.5	M10	62	0.09			34	
-SLSA4-115-M 42			7	1.5	115	42				55	11.4			87	0.1			64	
-SLRA4-115-M 42			10	3					65	50	14.4							54	
-140-M 60	1				140	60			80	-	-			112				64	
-SLSA4-140-M 67	2		7	1.5		67			60	80	14					6	64.7	84.3	
ST20-SLRA4-175-M 95	1		10	3	175	95	20		80	-	-	19.5		147	0.3			53.7	99.3
-SLSA4-200-M 97	2		7	1.5	200	97			90	110	17.2			172			7	39.4	104.5
ST25-SLSA4-245-M 97					245		25		120	125		24.5		217	0.6		6	49.7	105.6
-SLRA4-245-M 97			10	3							20.2							50.5	100.5
-315-M 67					315	67			220	95	17			287	0.9				70.5
-SLSA4-315-M195	1		7	1.5		195			120	-	-				0.7			49.7	112.4
ST19.05-SLS3/16-200	1	3/16	.31	.059	7.87	4.33	.750	.59	3.54			.728	M10	7.20	0.55	.24	-	2.76	-
ST10-SLSA5- 80-M 35	1	5	8	1.5	80	35	10	15	45	-	-	9.5	M 6	70	0.03	-	-	-	-
ST20-SLSA5-200-M110					200	110	20		90			19.2	M10	182	0.3	6		69.3	
ST25-SLSA5-290-M 97	2				290	97	25		180	110	18.2	24.5		272	0.8		7	69.7	114.5

CODE	Fig.	φD	φC	t	L	M	D1	H	L1	L2	φC1	φC2	g	h		φD2	φD3	H1	H2	
ST12-SLSA 6- 80-M 35	1	6	9	1.5	80	35	12	18	45	—	—	11.5	M 8	52	0.04	—	—	—	—	○
ST16-SLSA 6-115-M 42	2				115	42	16		60	55	13.4	15.5	M10	87	0.1	7	84.5			
-SLSB 6-115-M 42					10	2				65	50	14.4					54.5			
ST20-SLRB 6-120-M 42			14	4	120		20	70		18.4	19.5		92	0.2						
ST16-SLSB 6-140-M 60	1		10	2	140	60	16	80	—	—	15.5		112	0.1				64.5		
-SLSA 6-140-M 70			9	1.5		70		70										74.5		
ST20-SLSA 6-175-M105					175	105	20				19.5		147	0.3				109.5		
-SLSB 6-175-M 95			10	2		95		80										99.5		
-SLRB 6-175-M 60			14	4		60		115										64.5		
ST25-SLSB 6-205-M127	2		10	2	205	127	25	70	135	23.3	24.5		177	0.5				104.5		
-SLSA 6-230-M 97			9	1.5	230	97		120	110	19.2			202					94.5		
-SLRB 6-240-M 42			14	4	240	42		170	70	18.4			212	0.7		11	50.8	160		
ST32-SLSB 6-255-M157			10	2	255	157	32	70	185	26.5	31.5	M16	227	0.8		8	49.7	107.4		
ST25-SLSA 6-305-M185	1		9	1.5	305	185	25	120	—	—	24.5	M10	277					91.7	166.1	
ST32-SLRB 6-345-M 67	2		14	4	345	67	32	250	95	21	31.5	M16	317	1.6				50.5	73.5	
-SLSB 6-375-M157			10	2	375	157		190	185	26.5			347	1.4				49.7	107.4	
ST19.05-SLS1/4-200	2	1/4	.37	.059	7.87	3.94	.750	.71	3.94	3.94	—	.728	M10	7.20	0.55	.28	—	2.76	—	○
ST25-SLSA 7-230-M 97	2	7	10	1.5	230	97	25	20	120	110	20.2	24.5	M10	212	0.5	8	—	69.8	—	○
-320-M 97					320				210						302	0.9	7.5		44.7	
ST20-SLRB 8-100-M 30	1	8	18	5	100	30	20	24	70	—	—	19.5	M10	72	0.2	—	—	—	—	○
ST16-SLSA 8-115-M 50					11	1.5	115		50	16	65		15.5		87	0.1				
ST20-SLSB 8-145-M 70					13	2.5	145		70	20	75		19.5		117	0.2				
ST25-SLRB 8-160-M 42	2		18	5	160	42	25	110	50	22.4	24.5		132	0.5						
ST20-SLSA 8-175-M 85	1		11	1.5	175	85	20	90	—	—	19.5		147	0.3						
ST25-SLSB 8-175-M 97	2		13	2.5		97	25	70	105	23.2	24.5			0.4						
-SLRB 8-210-M 90	1		18	5	210	90		120	—	—			182	0.6	9	11	71.4	150		
-SLSA 8-230-M 97	2		11	1.5	230	97			110	21.2			202		—	—	—	—		
-SLSB 8-260-M140	1		13	2.5	260	140			—	—			232	0.7	9	11	121.4	200		
-SLSA 8-280-M160			11	1.5	280	160							252				141.4	220		
ST32-SLRB 8-285-M 67	2		18	5	285	67	32	190	95	25	31.5	M16	257	1.3		14	75.8	185		
-SLSB 8-375-M157			13	2.5	375	157			185	29.5			347	1.5		12	94.1	166.4		
ST25-SLSA 9-230-M 97	2	9	12	1.5	230	97	25	30	120	110	22.2	24.5	M10	60	0.6	9.6	—	61	—	○
-320-M 97					320				210						60	0.9				
ST25.4-SLS3/8-230	2	3/8	.49	.059	9.06	3.82	1	11.18	4.72	4.33	.89	.965	M10	2.36	1.43	.40	—	2.40	—	○
ST25-SLRB10-120-M 35	1	10	22	6	120	35	25	30	85	—	—	24.5	M10	60	0.4	10.6	—	61	—	○
ST20-SLSB10-120-M 50					16	3			50	20	70		19.5				0.2			
ST25-SLSB10-145-M 67	2								145	67	25		75	23	24.5			0.4		
ST20-SLSA10-145-M 70	1		13	1.5		70	20	75	—	—	19.5			0.2						
ST25-SLSB10-175-M105			16	3	175	105	25	70			24.5		154	0.5	11		155			
-SLRB10-210-M 90			22	6	210	90		120					149	0.7			150			
ST32-SLSB10-240-M170			16	3	240	170	32	70			31.5	M16	212	0.9		14	151.1	200		
ST25-SLSA10-255-M135			13	1.5	255	135	25	120			24.5	M10	194	0.7		—	195	—		
-SLSB10-275-M105			16	3	275	105		170						0.8						
ST32-SLRB10-285-M 67	2		22	6	285	67	32	190	95	29	31.5	M16	257	1.4		14	76.1	185		
-SLSA10-340-M210	1		13	1.5	340	210		130	—	—			312	1.3			191.1	270		
-SLSB10-360-M170			16	3	360	170		190					332	1.5			151.1	260		
ST42-SLSB10-445-M157	2				445	157	42	260	185	32.5	41.5	M24	417	2.7			97.1	165	×	
ST25-SLSA11-230-M110	1	11	14	1.5	230	110	25	30	120	—	—	24.5	M10	60	0.6	11.6	—	61	—	○
-320-M110					320				210							60	0.9			

Feature
Shrink-fit Heater
MONO 3° MONO CURVE
MONO Series
2PIECE type
UNO
HYPER version
STRAIGHT arbor
OTHERS
PERIPHERALS
Technical Information



CODE	Fig.	φD	φC	t	L	M	D1	H	L1	L2	φC1	φC2	g	h	Kg lbs	φD2	φD3	H1	H2	
ST25-SLSB12-120-M 42	2	12	19	3.5	120	42	25	30	70	50	23.4	24.5	M10	60	0.3	12.6	-	61	-	○
ST20-SLSA12-120-M 50	1		15	1.5		50	20			-	-	19.5			0.2					○
ST32-SLRB12-140-M 60			26	7	140	60	32		80			31.5	M16	112	0.7	13		109.5		×
ST25-SLSB12-150-M 80			19	3.5	150	80	25		70			24.5	M10	60	0.4		11	61	130	○
ST32-SLSB12-220-M150					220	150	32					31.5	M16	192	0.9		14	131.7	180	○
ST25-SLSA12-230-M110			15	1.5	230	110	25		120			24.5	M10	60	0.6	12.6	11	61	-	○
-SLSB12-250-M 80			19	3.5	250	80			170					0.8	13			170		○
ST32-SLRB12-260-M 70			26	7	260	70	32		190			31.5	M16	232	1.3		14	51.7	160	×
-SLSA12-315-M185			15	1.5	315	185			130					287	1.2			166.7	245	○
-SLSB12-340-M150			19	3.5	340	150			190					312	1.5			131.7	240	○
ST42-SLSB12-445-M157	2				445	157	42		260	185	35.5	41.5	M24	417	2.8	12.6		59.5	162.5	×
ST25.4-SLS1/2-230	1	1/2	.62	.059	9.06	4.33	1	1.18	4.72	4.33	-	.965	M10	2.36	1.33	.52	-	2.40	-	
ST32-SLRB16-175-M 45	1	16	32	8	175	45	32	32	130	-	-	-	M16	80	0.8	16.6	-	81	-	
ST25-SLSB16-175-M 50			24	4		50	25		125				M10		0.5					
ST32-SLSB16-290-M100					290	100	32		190			31.5	M16		1.4	17	14		190	
ST42-SLRB16-355-M 67	2		32	8	355	67	42		260	95	39	41.5	M24	327	2.7		21	73.5	-	
-SLSB16-445-M157	1		24	4	445	157				-	40.5			417	3			165.8	424.5	
ST42-SLRB20-170-M 70	1	20	38	9	170	70	42	40	100	-	-	41.5	M24	142	1.3	21	21	109.5	154	
ST32-SLSB20-175-M 50			29	4.5	175	50	32		125			31.5	M16	80	0.8		-	81	-	
ST42-SLSB20-255-M155					255	155	42		100			41.5	M24	227	1.7		22	194.5		
-SLRB20-330-M 70			38	9	330	70			260					302	2.6		22.6	189.5	314	
-SLSB20-415-M155			29	4.5	415	155								387	2.9	21.6	22	69.5	135	
ST42-SLRB25-170-M 42	2	25	45	10	170	42	42	45	100	70	49.6	53	M24	120	1.5	26	22.6	121	154	
-250-M 42					250				180		49.4	50		80	2.1	25.6	22	81	-	

Feature

Shrink-fit Heater

MONO 3° MONO CURVE

MONO Series

2PIECE type

UNO

HYPER version

STRAIGHT arbor

OTHERS

PERIPHERALS

Technical Information

Carbide type



ST16C-SLSB6-225

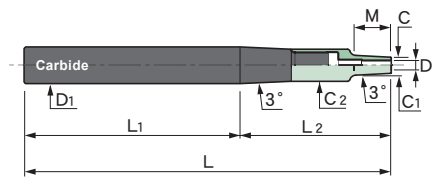

Thickness

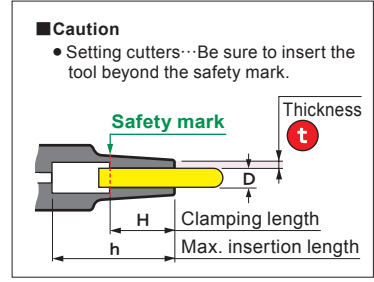

CODE	ϕD	ϕC	t	L	M	ϕD_1	H	L ₁	L ₂	ϕC_1	ϕC_2	h		H ₁				
ST10C-SLSA 3-160	3	6	1.5	160	12	10	9	120	40	7.3	10	19	0.2	17				
ST16C-SLSA 3-280				280		16		182	98				0.7					
ST10C-SLSA 4-160	4	7	1.5	160	12	10	12	120	40	8.3	10	19	0.2	17				
ST16C-SLSA 4-280				280		16		182	98				0.7					
ST12C-SLSB 6-175	6	10	2	175	19.1	12	18	125	50	—	12	27	0.3	25				
ST16C-SLSB 6-225				225	22	16		165	60				12.3		16	32	0.6	28
ST20C-SLSB 6-320				320	20	20		221	99				1.3		—	—	—	—
ST25C-SLSB 6-360				360	25	25		242	118				2.2		20	38	2.2	33
ST16C-SLSB 8-225	8	13	2.5	225	22	16	24	165	60	15.3	16	32	0.6	28				
ST20C-SLSB 8-270				270		20		200	70				20		38	1.1	33	
ST25C-SLSB 8-360				360		25		242	118				2.2		—	—	—	—
ST20C-SLSB10-270	10	16	3	270	22	20	30	200	70	18.3	20	38	1.1	33				
ST25C-SLSB10-360				360		25		242	118				2.2		—	—	—	

The Parts Code List for Carbide Straight Arbor

SET-CODE	CARBIDE SHANK	HEAD
ST10C-SLSA 3-160	ST10C- 7 -120	SH 7 -SLSA 3-40
-SLSA 4-160		-SLSA 4-40
ST12C-SLSB 6-175	ST12C- 9 -125	SH 9 -SLSB 6-50
ST16C-SLSA 3-280	ST16C- 7 -240	SH 7 -SLSA 3-40
-SLSA 4-280		-SLSA 4-40
-SLSB 6-225	-12.5-165	SH12.5 -SLSB 6-60
-SLSB 8-225		SH12.5 -SLSB 8-60
ST20C-SLSB 6-320	ST20C-12.5-260	SH12.5 -SLSB 6-60
-SLSB 8-270	-16 -200	SH16 -SLSB 8-70
-SLSB10-270		SH16 -SLSB10-70
ST25C-SLSB 6-360	ST25C-16 -290	SH16 -SLSB 6-70
-SLSB 8-360		-SLSB 8-70
-SLSB10-360		-SLSB10-70



Feature
Shrink-fit Heater
MONO 3°
MONO CURVE
MONO Series
2PIECE type
UNO
HYPER version
STRAIGHT arbor
OTHERS
PERIPHERALS
Technical Information

OTHERS

DETa-1 Collet Holder (DTA / DTB)

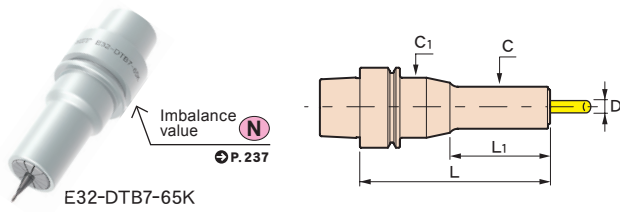

DETa-1 Collet (Precision collet)

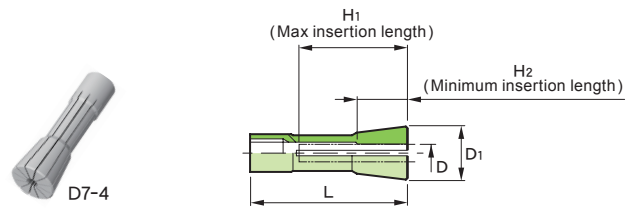

CODE	ϕD	L	ϕC	L1	kg	N	
E25 -DTB 3- 58	0.5 ~ 3.175	58	10	27	0.1	0.4	
E32 -DTA 3- 75	0.5 ~ 3.175	75	10	27	0.2	1.8	
-DTB 3- 65		65					0.6
-DTB 7- 65K*		1 ~ 7	21	30			0.9
E40 -DTA 3- 75	0.5 ~ 3.175	75	10	27	0.3	1.7	
-DTB 3- 70		70			0.3	0.9	
-DTB 7- 95	1 ~ 7	95	21	50	0.4	1.6	
-DTB12-110	2.5 ~ 13	110	30	90	0.5	2.8	
E50 -DTA 3- 80	0.5 ~ 3.175	80	10	27	0.5	2.1	
-DTB 3- 75		75				1.7	
-DTB 7-100	1 ~ 7	100	21	50	0.6	3.2	
-DTB12-115	2.5 ~ 13	115	30	89	0.8	4.2	
F63 -DTA 3- 90	0.5 ~ 3.175	90	10	27	0.8	2.3	
-120		120			0.9	2.7	
-DTB 3- 75		75			0.8	2.1	
-105		105			0.9	2.5	
-105L					57	0.8	2.1
F63M-DTB 7-100	1 ~ 7	100	21	50	0.9	3.3	
-DTB12-120	2.5 ~ 13	120	30	70	1.1	4.8	

CODE	ϕD	Collapsibility	$\phi D1$	L	H1	H2	Holder type
D 3-0.6 -P	0.5 ~ 0.6	0.1	7	40	36	6.9	DTA 3 DTB 3
-0.8 -P	0.6 ~ 0.8	0.2					
-1 -P	0.8 ~ 1						
-1.5 -P	1 ~ 1.5	0.5					
-2 -P	1.5 ~ 2						
-2.5 -P	2 ~ 2.5						
-3 -P	2.5 ~ 3						
-3.175-P	2.7 ~ 3.175						
D 7- 1.5-P	1 ~ 1.5	0.5	17	50	36	7 10 12	DTA 7 DTB 7
- 2 -P	1.5 ~ 2						
- 2.5-P	2 ~ 2.5						
- 3 -P	2.5 ~ 3	1					
- 4 -P	3 ~ 4						
- 5 -P	4 ~ 5						
- 6 -P	5 ~ 6						
- 7 -P	6 ~ 7						
D12- 4 -P	2.5 ~ 4	1.5	26	70	50	16 20 22	DTB12
- 6 -P	4 ~ 6	2					
- 8 -P	6 ~ 8						
-10 -P	8 ~ 10						
-12 -P	10 ~ 12						
-13 -P	11 ~ 13						

- Option
 - DETa-1 Collet
 - Wrench
- Std. Access.
 - Rod(DTA3)
- Caution
 - *It cannot use collapsibility of a collet. The holding diameter applies only to the reference diameter of collet.
 - HSK-E and F shank don't come with a coolant duct and cannot be attached. Consult us if you need it.

Accuracy

Runout accuracy	D3	D7-D12
Precision Collet	3 (6)μm	5 (10)μm

*Accuracy of collet alone, () means collapsibility usable.

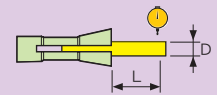

D	L
~10	4 x D
10 ~ 13	40

Spanner / Wrench

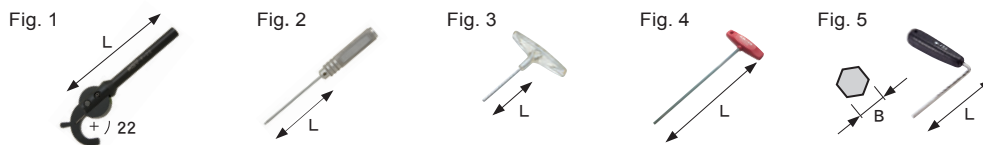

CODE	Shank type	Fig.	L	B	Tightening torque (N·m)
F -22	DTA 3	1	110	—	2~3
DW-2.5-110	DTB 3	2	103		
TW-4	E32 -DTB 7	3	77	4	14
-5	E40 -DTB 7	4	153	5	14
-6	DTB12		173	6	14
W -135DR	E40 -DTB12	5	110	5	18
	F63M -DTB 7				14
	DTB12				18

Cleaning Tool felt type (DTA3 / DTB3)

Please use to clean the inside of the holder.

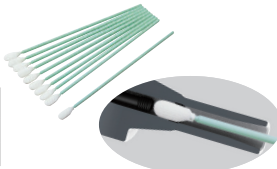

CODE	Q'ty
PCT01-10	10
-25	25

Rod (DTA3 type)

The attaching to the DTA3 type holder.

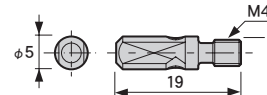

CODE	Holder type	Q'ty
PR-DTA3	DTA3	2 pcs.

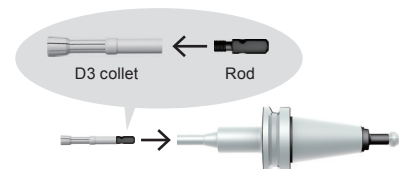

COLLET HOLDER (CTH/CTS)



E32-CTH10-55



E32-CTS10-50

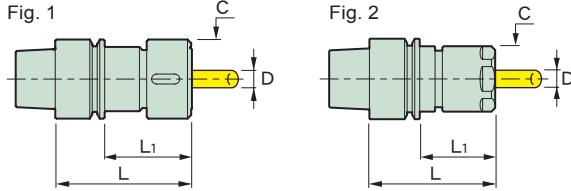

CODE	Fig.	ϕD	L	ϕC	L ₁	Kg
E32-CTH10-55	1	2.4 ~ 10	55	32	35	0.2
-CTS10-50 ※	2		50	26	30	
E40-CTH10-55	1	2.4 ~ 10	55	32	34	0.4
E50-CTH10-60	1	2.4 ~ 10	60	36	34	0.7
-90			90		64	0.9
-CTH20-75		5.8 ~ 20	75	50	49	
F63-CTH10-60	1	2.4 ~ 10	60	36	34	0.9
-90			90		64	1.1
-CTH20-75		5.8 ~ 20	75	50	49	

- Option** • Spring collet • Spanner
Caution • ※=It cannot use collapsibility of a collet. The holding diameter applies only to the reference diameter of collet.

Spring collet (Precision collet)

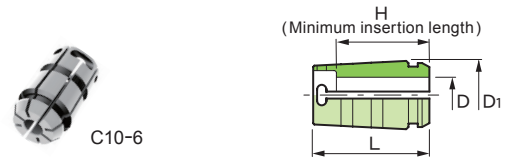

CODE	ϕD	L	ϕD_1	H	Holder type
C10-D-P	2.6 ~ 5.8 (0.2mm steps)	26	17.2	18	CTH10
	6 ~ 10 (0.2mm steps)			20	
C20-D-P	6 ~ 9.8 (0.2mm steps)	50	29.5	29	CTH20
	10 ~ 15.8 (0.2mm steps)			33	
	16 ~ 20 (0.2mm steps)			40	

ex. ϕD
C20-10-P

Spanner / Wrench

Fig. 1 Fig. 2

CODE	Fig.	Holder type	R	L
FC-32	1	E32 - CTH10	16	120
-36		F63 - CTH10	18	208
-50		- CTH20	25	281
RC-26	2	E32 - CTS10	—	240

Accuracy

Runout accuracy	Nominal shank size
Precision Collet	5 μm

※Accuracy of collet alone

D	L
~ 10	4 × D
10.2 ~ 20	40

Face Mill Arbor (FMC)



E50-FMC22-45

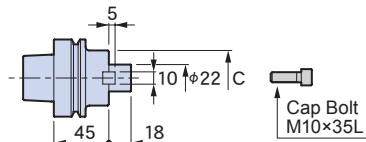

CODE	Cutter dia	ϕC	Kg
E50-FMC22-45	50, 63	42	0.7
F63-FMC22-45	50, 63	45	1

- Std. Access.** • Cap Bolt • Stopper Key
Note • The cap bolt may differ depending upon the shape of the cutter

Retention knob



Caution

- Retention knobs in this catalog are typical models for various machine tool companies. Confirm the correct retention knob design using the machine specifications sheet.
- We manufacture other kinds of retention knobs. Please consult us for the detail.
- When heating Mono Series shrink-fit holders, use a retention knob with a through-hole or remove the retention knob before heating. If you use a retention knob without a through-hole for the Mono Series shrink-fit holders, a cutter cannot be inserted into the holder because the air in the holder is not released. We can provide you with a retention knob with an air drain hole.

Compatible manufacturers	Standard type						For through spindle coolant type		
	BT30		BT40		BT50		BT30	BT40	BT50
	Standard type	Standard type with a through hole	Standard type	Standard type with a through hole	Standard type	Standard type with a through hole			
BROTHER	P30T-2	P-511	-		-		P-511	-	-
DMG MORI	P30T-1	P-445	P-141	-	P-143	-	-	P-435	P-513
FANUC	P30T-1	P-522	-		-		P-522	-	-
HOWA	P30T-1	P-445	P40T-1	P-297	P50T-1	P-299	-	-	-
JTEKT	-		P40T-1	P-297	P50T-1	P-299	-	P-297	P-299
KIRA	P30T-1	P-445	P40T-1	P-297	-		-	P-323-1	-
KITAMURA	P30T-1	P-445	P-348		P-323-1		-	P-323-1	P-400
KIWA	P30T-1	P-445	P-348	P-323-1	P-400		-	P-323-1	P-400
KOMATSU NTC	P30T-1	P-445	P40T-1	P-297	P50T-1	P-299	P-522	P-505	P-384
KURASHIKI	-		P40T-1	P-297	P50T-1	P-299	-	-	-
MAKINO	-		P40T-1	P-297	P50T-1	P-299	-	-	-
MATSUURA	P30T-2	P-511	P-348		P-323-1		-	P-323-1	-
MAZAK	P-399		P-227		P-400		-	P-227	P-514
MITSUI SEIKI	-		P-007	-	P-008	P-250	-	-	-
NIDEC	-		P40T-1	-	P50T-2	-	-	-	-
NIIGATA MACHINE TECHNO	-		-		P50T-2	P-419	-	-	-
OHTORI	-		P40T-1	P-297	P50T-1	P-299	-	-	-
OKK	-		P40T-1	-	P-143		-	-	-
OKUMA	-		P40T-2	P-339	P50T-2	P-419	-	P-499	P-419
SHIBAURA MACHINE	-		(MB series)				-	-	-
SHIZUOKA	P30T-1	P-445	P-141	P-498	P-143	P-402	-	-	-
SNK	-		P40T-2	P-339	P50T-2	P-419	-	-	-
SUGINO	P30T-2	P-497	-		-		-	-	-
YAMAZAKI GIKEN	-		P40T-1	P-297	P50T-2	P-419	-	-	-
YASDA	-		P-348	P-438	P50T-1	P-299	-	P-509	P-585
					P-400 (YBM1218V)				

BT30

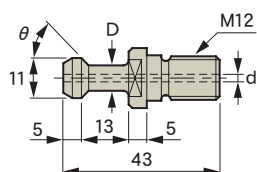

CODE	φD	φd	θ	NOTE
P30T-1	7	-	45	MAS-1
P-445		3		P30T-1 through hole
P30T-2		-	60	MAS-2
P-497		2		P30T-2 through hole
-522	8	4	45	FANUC center-through
-511	7.5	2.5	60	BROTHER center-through

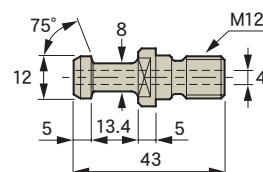

CODE	NOTE
P-399	JIS30P

BT40

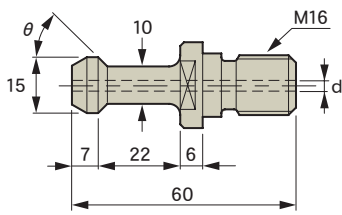

CODE	ϕd	θ	NOTE
P40T-1	—	45	MAS-1
P-297	4		P40T-1 through hole
P40T-2	—	60	MAS-2
P-339	4		P40T-2 through hole
P-141	—	90	—
-498	4		P-141 through hole
P-505	3	45	KOMATSU NTC center-through

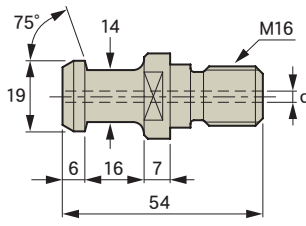

CODE	ϕd	NOTE
P-348	—	JIS40P
-323-1	7	P-348 through hole
-499	4	OKUMA center-through
-438	7	YASDA through hole
-509		YASDA center-through

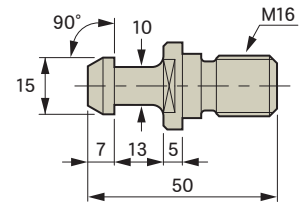

CODE	NOTE
P-007	MITSUI SEIKI

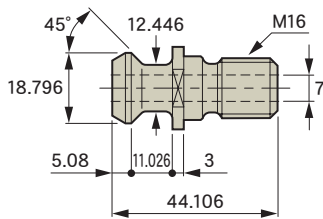

CODE	NOTE
P-227	MAZAK

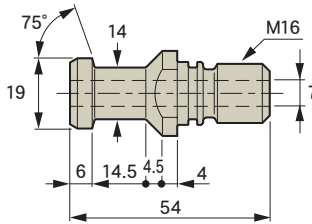

CODE	NOTE
P-435	DMG MORI center-through

BT50

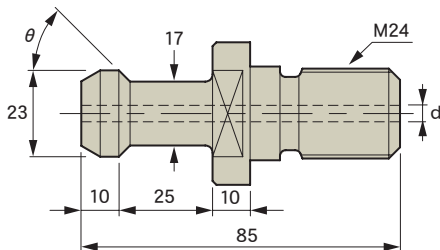

CODE	ϕd	θ	NOTE
P50T-1	—	45	MAS-1
P-299	6		P50T-1 through hole
P50T-2	—	60	MAS-2
P-419	6		P50T-2 through hole
P-143	—	90	—
-402	7		P-143 through hole
-513	8	90	DMG MORI center-through
P-384	5.5	45	KOMATSU NTC center-through

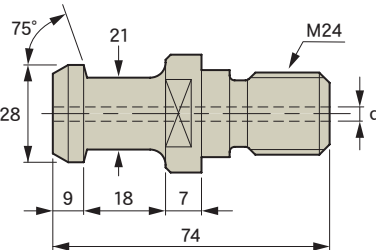

CODE	ϕd	NOTE
P-400	10	JIS50P
-288-1	6	P-400 through hole
-585	5.5	YASDA center-through

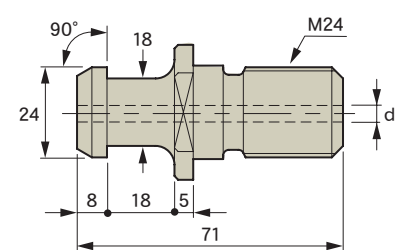

CODE	ϕd	NOTE
P-008	—	MITSUI SEIKI
-250	8	P-008 through hole

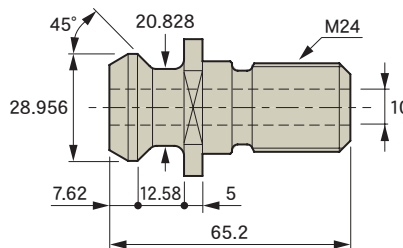

CODE	NOTE
P-514	MAZAK

SLIMLINE collet installation

You can install a SLIMLINE collet without removing the retention knob if the center hole dia. is more than 6mm.



Coolant duct (HSK-A)

Coolant duct (Fixed type)

CODE	Fig.	ϕC	L	ϕD	W	G	Shank type
CD 40-01	1	8	29.5	4	4	M12×1	HSK-A40
-03	3		35.5				
-04			36.5				
CD 50-01	1	10	33	5	5	M16×1	HSK-A50
-03	3		39				
-04			59				
CD 63-01	1	12	36.5	6	6	M18×1	HSK-A63
-02	2						
-03	3				5		
-04			60.5				
CD100-01	1	16	44	8	8	M24×1.5	HSK-A100
-02	2			10.3			

Note

- A coolant duct comes with below shank holders as a standard accessory. However, for the CD50-03 and the CD63-03, CD50-04 and CD63-04 come as options, respectively.

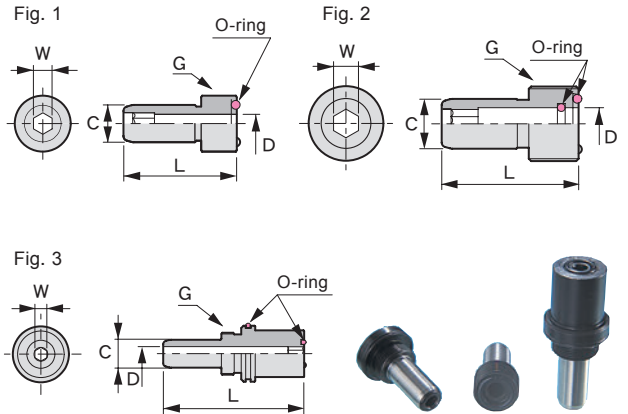

Dummy duct

CODE	ϕC	L	W	G	Shank type
CD 40-A1	8	29.5	4	M12×1	HSK-A40
CD 50-A1	10	33	5	M16×1	HSK-A50
CD 63-A1	12	36.5	6	M18×1	HSK-A63
CD100-A1	16	44	8	M24×1.5	HSK-A100

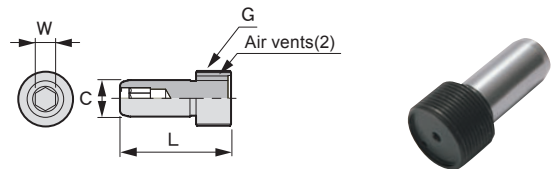

⚠ Cautions for shrinking operation.

Remove the coolant duct when using the hot air heater. If not, the O-ring will be damaged by the heat. (Removal is not necessary with the induction heater.) Use the dummy duct when the spindle coolant capability is not in use. The dummy duct does not need to be removed when heated.

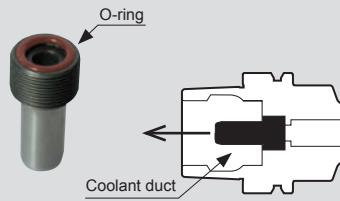

Coolant duct (Swing type)

CODE	Fig.	ϕC	L	ϕD	G	Shank type
CD 63-01F	1	12	36.5	7	M18×1	HSK-A63
-03F	2		45.5	6.5		
CD100-01F	1	16	44	10	M24×1.5	HSK-A100

Note

- Some machine tool companies recommend using a swing type coolant duct. We can exchange our standard fixed type coolant duct with a swing type at your request.
- If the replacement of the coolant duct is needed after the purchase, use the wrench CD63-01F-RNT.

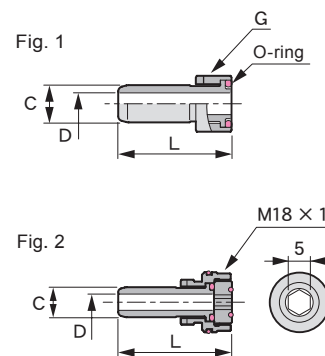

PERIPHERALS

TOOL SET UP STATION

Work table
6S DESK



6SD

➔ P. 220

Tool washing machine
CLEAN BOX



CBX

➔ P. 221

Cutting tool cover
TOOL CAP TCC type

TCC



➔ P. 222

Cutter protection box
ENDMILL HOUSE

EMO

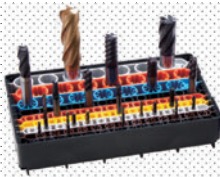

➔ P. 223

**TOOL HOLDER
STORING CABINET**

HBX



➔ P. 224

Tool clamping fixture
**TOOL SET UP
STAND**

**Petit Ball
MY CUBE
HF SERIES**

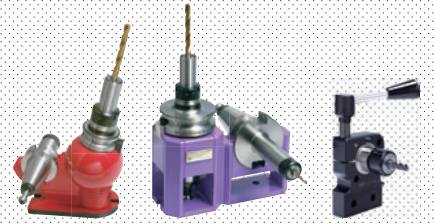

➔ P. 225

Cleaning Tool
for a spindle taper hole
STAR DUST

CLT



➔ P. 226

For machine spindle
maintenance
**TEST BAR
CHECKMATE**

**CMA
CMB**

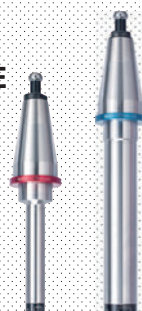

➔ P. 227

Set up the original point
on the Z axis / measuring tool
for reference position
Goo CHECKER

ZPM



➔ P. 228

The teaching DVD
with practical maintenance tools
MAINTENANCE VIDEO

MTN



➔ P. 229

TOOL SET UP STATION 6S DESK

Work table

Ensures safe tool settings! Improves the work environment in the factory!

- ▷ Helps in the rapid implementation of the five S's in your factory.
- ▷ Compact and space saving.
- ▷ Do-it-yourself style allows you to do assembly.



White board and Punched board

Useful as a bulletin board or message board, and for attaching drawings. Freely mounting position on the left or right side.

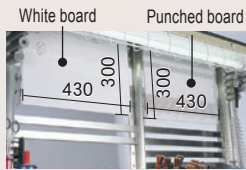

Tool insert stand (option)

Insert and store frequently used hand tools, stationary, etc.



Shelf board

Shelf is deep enough for a laptop computer, and the shelf can be attached at whatever height you desire.

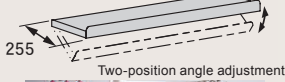

Hook base panel

Arbitrary attachment and recombination. Effective utilization of a rear space.



Usage example of backside application. Trash cans are not provided.

Dust Shooter (option)

Easy trash separation. Comes with two kinds of sign seals.

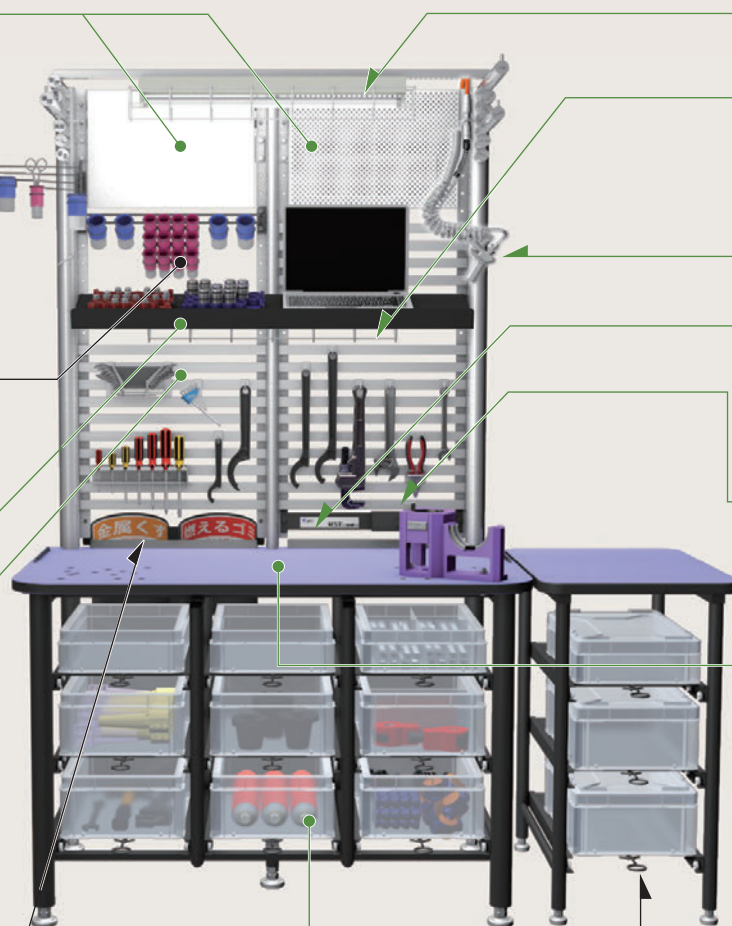

Upper lighting

Safety light cover.

Lower lighting

Brightly lit, safe work space.



Air gun

Can be mounted on either the right or left.

Safety stopper

Prevents dropping of cutting tools and tool holders.



Lighting switch and socket

Upper lighting (32W) and under shelf lighting (20W) (max. capacity 1500W)



Tabletop

The tool setup stand (sold separately) can be installed anywhere using the tabletop holes. No need to put your own holes in the tabletop.



Container box

The see-through box allows easy storage and organizing.



Side Table (option)

Side Table comes with:
Container box (CN-103) 1 pc.
Container box (CN-150) 2 pcs.
Container box lid (CN-FT) 3 pcs.

Tool Set Up Stand (option)

▷ P. 225



MY CUBE

Petit Ball

※This image includes the options. Tool is not included

CODE

6SD-01

For details, please contact MST and ask for a catalog.



Dimensions

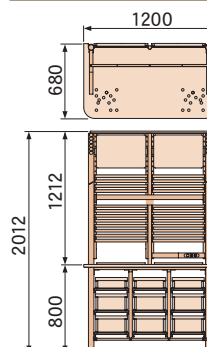

132 kg

Uniformity with stand load 100 kg

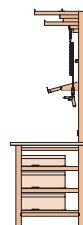

Std. Access.

CODE	Description	Q'ty	Description	Q'ty
6SD-FBP	Hook base panel	12pcs.	Shelf board	1pc.
-FS	Short hook	3pcs.	Upper lighting / Lower lighting	1ea.
-FL	Long hook	2pcs.	※Select 50Hz or 60Hz	
-UFS	U-type short hook	3pcs.	Power code set	1set
-UFL	U-type slong hook	1pc.	(Socket / Lighting / switch / Powercode)	
-FSP	Hook fot spanner	1pc.	White board.	
-FDR	Hook fot driver	1pc.	Marker pen for whiteboard.	
CN -103	Container box	3pcs.	Whiteboard eraser.	1set
-150		6pcs.	Magnet pocket.	
6SD-AIR	Air gun set	1set	Punched board.	
			Name seal set.	
			Magnets(3pcs.).	
			Memo book.	

Caution

- Assembly by buyer.
- Customers pay the shipping cost.
- 100V electric power supply (transformer is required)

TOOL SET UP STATION CLEAN BOX

Tool washing machine

Wash the tooling holders, collets, nuts, cutting tools, and small work-pieces thoroughly to maintain their accuracy!

- ▷ Wash tool holders, cutting tools and jig fixtures.
- ▷ No plumbing required.
- ▷ Safe cleaning system using water.
- ▷ Built-in water heater improves washing capability.

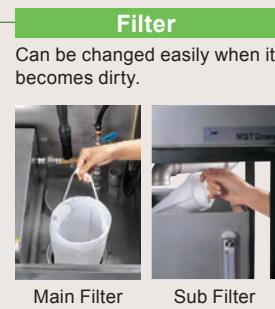
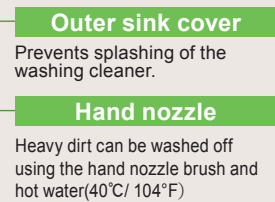
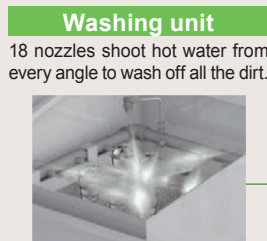

The sink, washing unit and tank are made of stainless steel, resulting in easy maintenance and less staining.

CODE
CBX-01

Dimensions

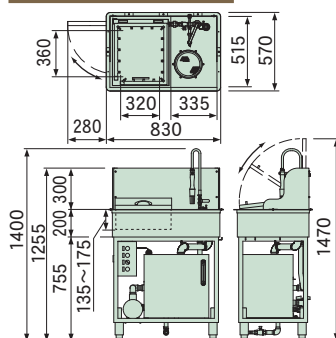

Specifications

Material	SUS304(Sink, Tank, Cleaning unit) SS400 (Base frame)
Tank	Approx. 65L(Level gauge with thermometer is standard accessory)
Pump	0.3~0.51kw (50/60Hz) (Produced by Grundfos)
Heater	3kw (with temperature control)
Weight	Approx. 100kg (165kg, including cleaning fluid)
Voltage	3-phase 200V (Rated 15A)

Std. Access.

CODE	Description	Q'ty
CBX-HNZ	Hand nozzle	1pc.
-MFIL	Main filter	2pcs.
-SFIL	Sub-filter	2pcs.
-TRP	Drain trap	1pc.
-GSTP	Rubber drain plug	1pc.
-WBSK	Washing basket	1pc.
-WTBL	Washing table	1pc.
	Sink outer cover	1set.
	Hook	2pcs.
	Bamboo brush	1pc.
	Primary power code (plug attached 15m)	1pc.

Caution

- Be sure to use water-soluble cleaning fluid.
- Customers pay the shipping cost.
- 200V electric power supply (transformer is required)

See-through tool cover. You can take care of tools safety and simply.



The tool is visible!

φ 5.4 ~ 60

Prevents chipping and damage to cutting tools

The cutting tool cover protects the user from injury at the time of work while protecting breakage of the cutting edge. Minimize grinding costs for reconditioning and lead to reduced operating costs.

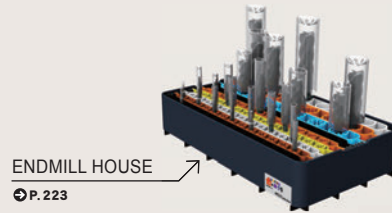

Not slip off



Cutter case



CODE	φD	h ₁	H	Q'ty
TCD03-50	3	—	25	50
TCD04-50	4	—	32	50
TCC0607- 50	5.4~ 6.7	35	40	50
-100				100
-500				500
TCC0709- 50	6.8~ 8.9	35	40	50
-100				100
-500				500
TCC0911- 50	8.9~10.9	65	70	50
-100				100
-500				500
TCC1113- 50	10.9~13.4	65	70	50
-100				100
-500				500
TCC1418- 25	13.8~17.8	100	110	25
- 50				50
-250				250
TCC1822- 25	17.8~22.4	100	110	25
- 50				50
-250				250
TCC2228- 25	22.3~28	135	150	25
- 50				50
-250				250
TCC2836- 10	28 ~36	130	150	10
- 20				20
- 50				50
-200				200
TCC3646- 10	36.2~47	165	190	10
- 20				20
- 50				50
-200				200
TCC4760- 10	46 ~60	160	190	10
- 20				20
- 50				50
-200				200

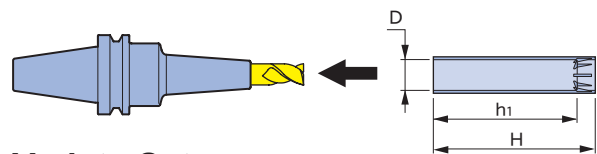

Variety Set

Each size comes in a set of two.

CODE	Q'ty
TCC-F	2 pieces per cutting tool over size for TCC0607 to 4760 (total of 20 pieces per set)

Usage

- 1 Hold the mouth of the tool cap vertically, and then press it so that its oval shape becomes round.
- 2 Once the mouth of the tool cap becomes round, push it into the cutting tool or tool holder.

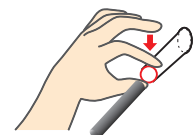
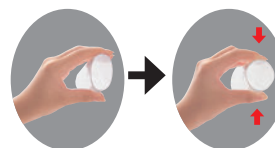

TCA type— Attaches to the tip of a tool holder.

TCB type— Attaches directly to the tip of the cutting tool.



General catalog for further reference...

Feature

Shrink-fit Heater

MONO 3° MONO CURVE

MONO Series

2PIECE type

UNO

HYPER version

STRAIGHT arbor

OTHERS

PERIPHERALS

Technical Information

Are you having trouble storing your cutting tools ?



Cutting tool expenses increase due to cutting edge chipping.

The required cutting tool cannot be found easily.

Save cutting tool expenses and time with the optimum working environment.

- ▶ Cutting tool life is extended because the cutting edge is not dulled from striking other cutters.
- ▶ You can find the required cutting tool immediately.

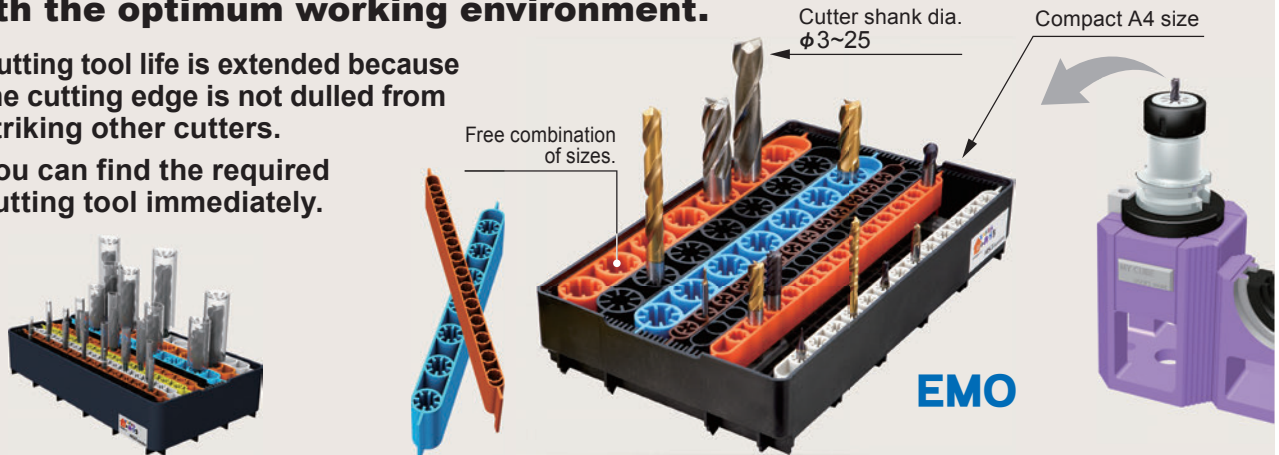

Value set

This is a convenient value set that can be immediately used and handles tool shank diameters of 3 mm to 12 mm. (Stores 156 cutting tools)

CODE	Stand	Base	TOOL CAP	TOOL CAP storage box																																
EMO-SET-01	<table border="1"> <thead> <tr> <th>Cutter dia</th> <th>Q'ty</th> </tr> </thead> <tbody> <tr><td>φ 3</td><td>1</td></tr> <tr><td>φ 4</td><td>2</td></tr> <tr><td>φ 6</td><td>3</td></tr> <tr><td>φ 8</td><td>2</td></tr> <tr><td>φ 10</td><td>2</td></tr> <tr><td>φ 12</td><td>2</td></tr> </tbody> </table>	Cutter dia	Q'ty	φ 3	1	φ 4	2	φ 6	3	φ 8	2	φ 10	2	φ 12	2	<table border="1"> <thead> <tr> <th>Q'ty</th> </tr> </thead> <tbody> <tr><td>1</td></tr> </tbody> </table>	Q'ty	1	<table border="1"> <thead> <tr> <th>Cutter dia</th> <th>Q'ty</th> </tr> </thead> <tbody> <tr><td>φ 3</td><td>50</td></tr> <tr><td>φ 4</td><td>50</td></tr> <tr><td>φ 6</td><td>50</td></tr> <tr><td>φ 8</td><td>50</td></tr> <tr><td>φ 10</td><td>50</td></tr> <tr><td>φ 12</td><td>50</td></tr> </tbody> </table>	Cutter dia	Q'ty	φ 3	50	φ 4	50	φ 6	50	φ 8	50	φ 10	50	φ 12	50	<table border="1"> <thead> <tr> <th>Q'ty</th> </tr> </thead> <tbody> <tr><td>1</td></tr> </tbody> </table>	Q'ty	1
	Cutter dia	Q'ty																																		
φ 3	1																																			
φ 4	2																																			
φ 6	3																																			
φ 8	2																																			
φ 10	2																																			
φ 12	2																																			
Q'ty																																				
1																																				
Cutter dia	Q'ty																																			
φ 3	50																																			
φ 4	50																																			
φ 6	50																																			
φ 8	50																																			
φ 10	50																																			
φ 12	50																																			
Q'ty																																				
1																																				
			<p>φ 3 : 13pcs. φ 4 : 26pcs. φ 6 : 39pcs. φ 8 : 26pcs. φ 10 : 26pcs. φ 12 : 26pcs.</p>																																	

Stand

Parts for storing and securing cutting tools. It is possible to identify the cutting tool size by color, and the cutting tool you need can be found at a glance. Use this stand inserting it into the base.

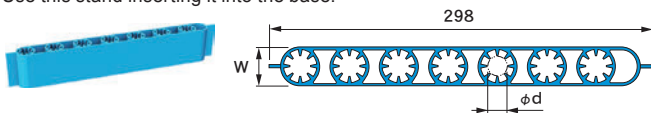

CODE	φd	W	max. Q'ty	Color	Q'ty
EMO-STD 3-2	3	15 mm (1W)	13 pcs./cutting tools/stand	Black	2
				5	
-STD 4-2	4			Brown	2
					5
-STD 6-2	6			Gray	2
					5
-STD 8-2	8			Yellow	2
					5
-STD10-2	10			Orange	2
					5
-STD12-2	12	Black	2		
			5		
-STD16-2	16	30 mm (2W)	7 pcs./cutting tools/stand	Blue	2
				5	
-STD20-2	20			Orange	2
					5
-STD25-2	25			Gray	2
					5

Base

Container for holding the stands. Stands can be arranged by changing the combination of stands freely.

CODE	Q'ty
EMO-BAS-1	1
-3	3

Note

- 12 rows for the stands of 3mm to 12mm diameter or 6 rows for the stands of 16mm to 25mm diameter.
- The left-right orientation of the stands can be set.



Example of stand arrangement

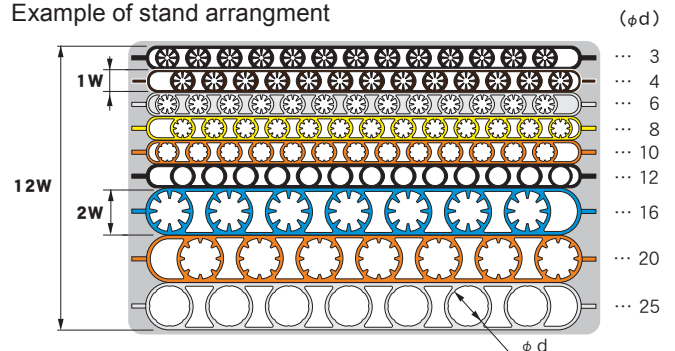

TOOL HOLDER STORING CABINET

Compact Storage Box for anti-rust treatment of tool holders.

Orderly storing with name plate

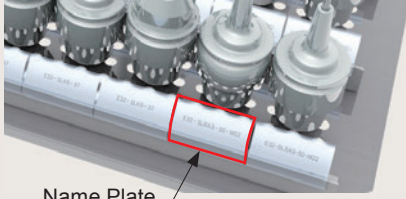

Name Plate

Transparent case!!

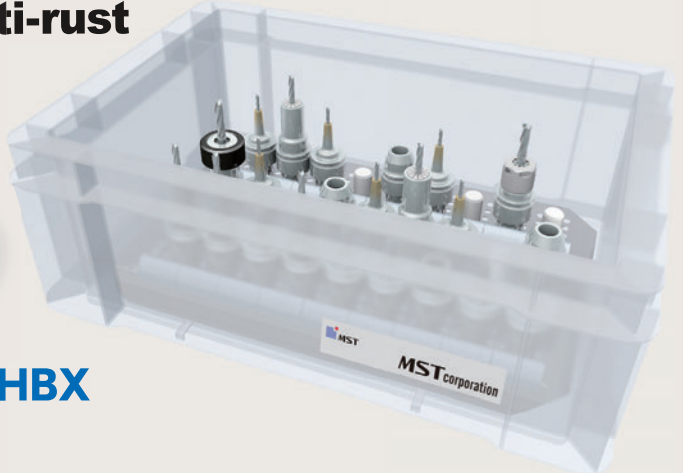

Freely arrangeable

A multi-hole base plate is employed. Supports a variety of holder specifications using pins that can be freely changed and relocated.

HBX

Three types of container boxes.

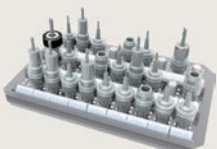

Horizontal type



Vertical type

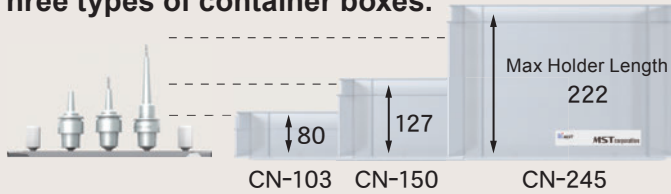

Standard Set

CODE	max. Q' ty	Container box	Pin	Q' ty	Shank type
HBX-A40	24	CN-150	HBX-PNE40	18	HSK-A40
-A50	15	-245	-PNE50	15	-A50
-E25	40	-150	-PNE25	32	-E25
-E32			-PNE32		-E32
-E40	24		-PNE40	18	-E40
-E50	15	-245	-PNE50	15	-E50
-F63	10	-150			-F63
-15T	40		-PN15T	16	15T(BROTHER)
-20T			-PN20T		RS20/20T(SUGINO)

Contents of set

- Base plate ●Container box ●Pin

Option

- Eyenut ●Rail ●Name Plate ●Lid for Container Box

Note

- Knock-down type. A wrench (5mm) is required.

Base plate

A multi-hole base plate is employed. Supports a variety of holder specifications using pins that can be freely changed and relocated.

CODE
HBX-BP01

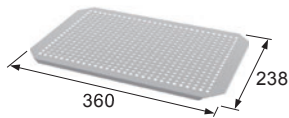

Container box

CODE	H		Shank type
	Outside dimension	Inside dimension	
CN-103	103	88	—
-150	150	135	E25, 32, 40/15T/20T
-245	245	230	A50, E50, F63

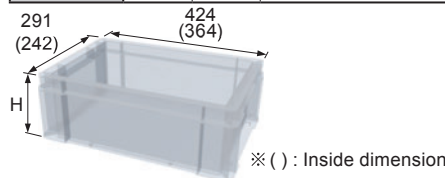

Pin

CODE	Q' ty	Size
HBX-PNE25	10	φ13.5 × H20
-PNE32		φ16.5 × H25
-PNE40	5	φ20.5 × H29
-PNE50		φ25.5 × H36
-PN15T		φ26.5 × H54
-PN20T		φ30.5 × H62

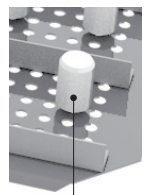

Pin

Std. Access.

- Mounting bolt (M6)

Eyenut

CODE	Q' ty
HBX-ENM6	2

Std. Access.

- Mounting bolt (M6)

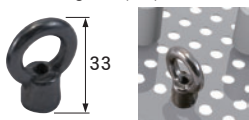

Rail (for name plate)

CODE	Q' ty	L	NOTE
HBX-R210	6	210	Vertical type
-R330	4	330	Horizontal type

Std. Access.

- Mounting bolt (M5)

Required for attaching name plate

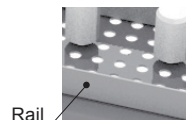

Name plate

CODE	Q' ty
HBX-NP01	40

Attaches easily to the rail.

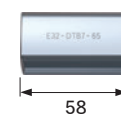

Freely cut to required overall length

Lid for container box

CODE
CN-FT



Feature

Shrink-fit Heater

MONO 3° MONO CURVE

MONO Series

2PIECE type

UNO

HYPER version

STRAIGHT arbor

OTHERS

PERIPHERALS

Technical Information

TOOL SET UP STAND

Tool clamping fixture

The setup time can be shortened. Not only can you mount cutting tools simply and quickly without using other tools, but also clamping collets and retention knobs!

フープール
Petit Ball 40
BT40 / DIN40 / CAT.40



Freely set vertically or horizontally

Guaranteed accuracy

Uses a special resin that prevents scratches on the taper.



マキューブ
MY CUBE 50
BT50 / DIN50 / CAT.50
マキューブ
MY CUBE 100
HSK-A100



Vise clamping type
HF SERIES
BT30 / BT40 / BT50
HSK-A40 / A50 / A63 / A100
E32 / E40 / E50 / F63
T40 / T50 / T63 / T100



Affordable



Petit Ball / MY CUBE

CODE	Shank type	Kg
PETIT BALL 40	BT40 / CAT. 40 / DIN40	6.1
MY CUBE 50	BT50 / CAT. 50 / DIN50	9.7
MY CUBE 100	HSK-A100, T100	9.6

Option

- Adapter (Petit Ball40, MY CUBE 50)
- Std. Access.
- Name plate

Caution

- Prepare 2 bolts for installation.
(Petit Ball : M8, MY CUBE : M12)

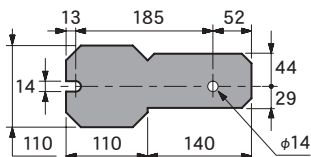
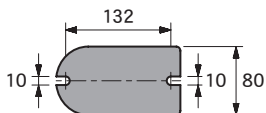
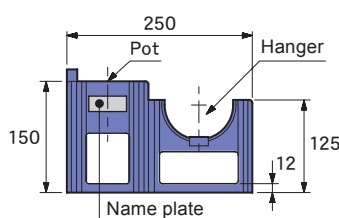
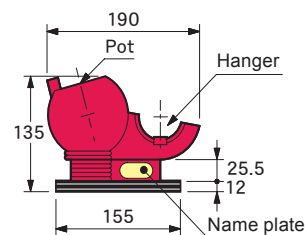

HF series

CODE	Fig.	Shank type	H	W	t	Kg
HF-BT30	1	BT30	77	70	30	0.8
-BT40		BT40	90	90	37	1.2
-BT50		BT50	—	—	—	2.2
HF-A40	1	HSK-A40, T40	72	60	30	0.8
-A50		-A50, T50	77	70	37	1
-A63		-A63, T63	87	90	—	1.2
-A100		-A100, T100	—	—	—	2.1
HF-E32	3	HSK-E32	98	64	—	1
-E40		-E40	100	70	—	1.1
-E50		-E50	106	80	—	1.3
HF-F63	3	HSK-F63	120	90	—	1.6

Adapter

Multi-purpose usage

CODE	Model	Adapter	Shank type	
AP40-T30V	PETIT BALL 40	For pot	BT30	
-T30H		For hanger	BT30	
-S25H			ST25T-DTB7	
-S32H			ST32T-DTB7, 12	
AP50-T30V	MY CUBE 50	For pot	BT30	
-T40V			BT40/CAT.40/DIN40	
-A63V			HSK-A63, T63	
-F63V			HSK-F63	
AP50-T30H		For hanger	BT30	BT30
-T40H			BT40	BT40
-A63H			HSK-A63, T63	HSK-A63, T63
-F63H			HSK-F63	HSK-F63
-S25H		ST25T-DTB7	ST25T-DTB7	
-S32H		ST32T-DTB7, 12	ST32T-DTB7, 12	

Adapter for pot



Adapter for hanger

Adapter for pot

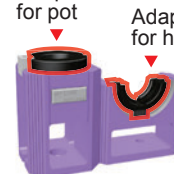

Adapter for hanger



At your request, your company name will be engraved.

Up to 12 characters (upper-case alphabetic characters, numeric characters, and/or hyphens).



Petit Ball



MY CUBE

Fig. 1

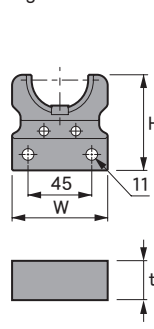

Fig. 2

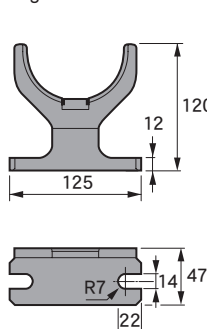
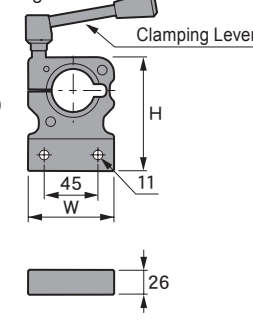

Fig. 3



STAR DUST

Feature

Shrink-fit Heater

MONO 3° MONO CURVE

MONO Series

2PIECE type

UNO

HYPER version

STRAIGHT arbor

OTHERS

PERIPHERALS

Technical Information

Achieves high-precision machining by cleaning the machine spindle tapered hole.

Replaceable wiper

Dirt doesn't re-adhere thanks to the use of replaceable wipers. When wipers get dirty, please change their position, and when the entire wiper gets dirty, please replace it. This will allow your operations to always take place under clean conditions. It is very economical compared to disposable cleaners.



Excellent dirt adsorption

We use a spongy resin for the wiper. Micron-size air bubbles catch and hold on to oil and powdery cutting chips.

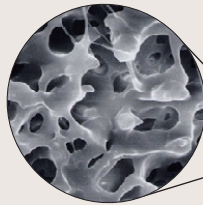

Electron microscope photo



SET CODE	Enabled spindles and holders	Plug code	Grip code
CLT-NT30-G2	BT30 / DIN30 / CAT.30	CLT-NT30	GR25-100
-NT40-G3	BT40 / DIN40 / CAT.40	-NT40	GR35-100
-NT50-G3	BT50 / DIN50 / CAT.50	-NT50	
-A40 -G2	HSK-A40 / T40	CLT-A40	GR25-100
-A50 -G2	-A50 / T50	-A50	
-A63 -G3	-A63 / T63	-A63	GR35-100
-A100-G3	-A100 / T100	-A100	
-E 25 -G1	HSK-E25	CLT-E25	GR18- 80
-E 32 -G4	-E32	-	-
-E 40 -G2	-E40	-E40	GR25-100
-E 50 -G2	-E50	-E50	
-F 63 -G2	HSK-F63	CLT-F63	GR25-100
-F 80 -G3	-F80	-F80	GR35-100
CLT-SLK 6-G1	SLK 6	CLT-SLK 6	GR18- 80
-SLK 8-G1	SLK 8	-SLK 8	
-SLK12-G2	SLK12	-SLK12	GR25-100
-C10 -G1	CTH10 / CTA10	CLT-C10	GR18- 80
-C20 -G2	CTH20 / CTA20	-C20	GR25-100
-C25 -G3	CTH25 / CTA25	-C25	GR35-100
-D 7 -G1	DTA 7 / DTB 7 / DTE 7	CLT-D 7	GR18- 80
-D12 -G4	DTA12 / DTB12 / DTE12	-	-

Replacement Wiper

This contains 3 sets.

CODE
CWP-NT30
-NT40
-NT50
-A40
-A50
-A63
-A100
-E 25
-E 32
-E 40
-E 50
-F 63
-F 80

CODE
CWP-SLK 6
-SLK 8
-SLK12
-C10
-C20
-C25
-D 7
-D12

※ Plugs and grips can be purchased separately.
 ※ 3 sets of wipers are included with each set.

Plug

For Spindle	For Holder
CLT-NT30 -NT40 -NT50	CLT-SLK 6 -SLK 8 -SLK12
CLT-A40 -A50 -A63 -A100	CLT-C10 -C20 -C25
CLT-E25 -E40 -F63 -F80 -E50	CLT-D 7

Grip

GR35-100	φ35 100
GR25-100	φ25 100
GR18-80	φ18 80

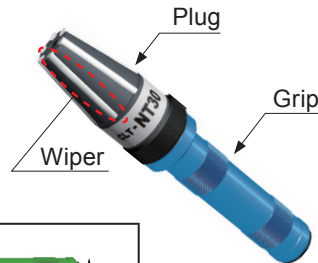

TEST BAR CHECKMATE

For machine spindle maintenance

Feature
Shrink-fit Heater
MONO 3° MONO CURVE
MONO Series
2PIECE type
UNO
HYPER version
STRAIGHT arbor
OTHERS
PERIPHERALS
Technical information

The maintaining machine spindle run-out accuracy allows superior machining quality. Maximizes tool holder performance!

- ▷ 20% lighter hollow design makes it easy to use.
- ▷ The actual measurement values are marked on the body.
- ▷ Ideal for setting Z axis datum.
- ▷ Reasonable price.

You can recognize the exact run-out accuracy and the highest run-out of the spindle.

You can check the spindle condition more precisely using the run-out value and position marked on the body.

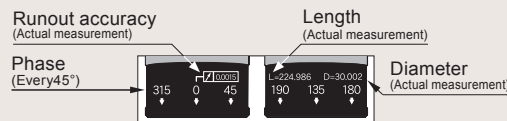

Periodically checking the run-out accuracy will result in superior machining.

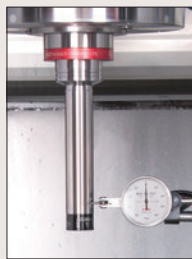

It can be installed into the spindle in every phase.

There is no drive-key groove, so measurements can be made without worrying about the phase.



Handy CMA type

Allows you to check the dynamic accuracy thanks to optional balance adjustment.

The name ring and scale ring protect it from scratches and dents.

The taper area and straight area do not touch the table surface even if they are placed horizontally.

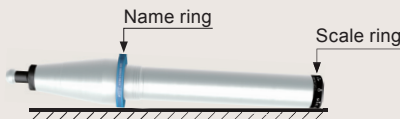

Full-fledged CMB type

Z-axis deflection and spindle travel accuracy can be measured.

	CODE	Fig.	φD	φD1	φD2	L	L1	L2	Kg		
BT/DIN/CAT.	NT30 -CMA20-125	1	20	32	50	125	45	65	0.7		
	NT40 -CMA25-175	2	25	42	63	175	50	110	1.3		
	NT50 -CMA30-225		30	53	80	225	65	145	3.5		
	NT30 -CMB30-175	1	30	32	50	175	45	115	1.0		
	NT40 -CMB40-325	2	40	42	63	325		265	2.8		
	NT50 -CMB50-325		50	53	80		60	250	5.7		
HSK-A / HSK-E	HSK32 -CMA20-125	3	20	26	37	125	35	75	0.4		
	32			50	45		65	0.5			
	HSK40 -CMA25-175	4	25	42	63	175	50	110	1.0		
	HSK63 -CMA25-175								1.2		
	HSK80 -CMA30-225	4	30	53	80	225	65	145	2.2		
	HSK100-CMA30-225				100				3.0		
	HSK125-CMA30-225				125				4.1		
	HSK32 -CMB25-175	3	25	26	37	175	35	125	0.7		
	HSK40 -CMB30-175								30	32	50
	HSK50 -CMB40-225	4	40	42	63	225	45	165	1.8		
	HSK63 -CMB40-325								325	265	2.7
	HSK80 -CMB50-325								50	53	80
HSK100-CMB50-325	4	50	53	100	325	45	265	5.2			
HSK125-CMB50-325				125				6.3			
HSK63F-CMA25-175				175				50	110	1.2	
HSK-F	HSK80F-CMA30-225	4	30	53	80	225	65	145	2.3		
	HSK63F-CMB40-325								4	40	42
	HSK80F-CMB50-325	50	53	80	60	250	4.5				

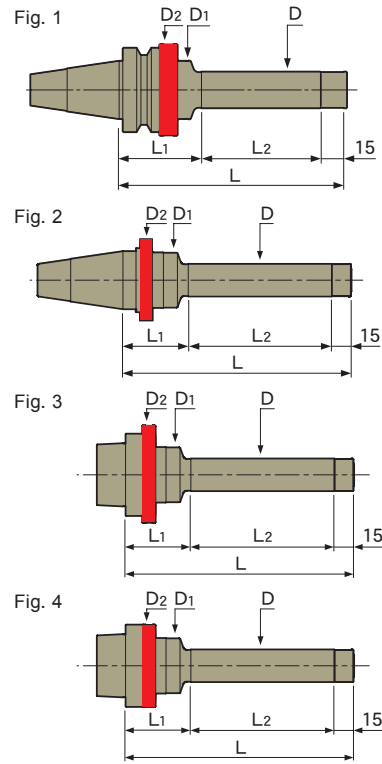

The sub-zero treatment prevents secular change.

Option

- Coolant duct(HSK-A)
- Retention knob(BT)
- Exclusive retention knob(CAT. / DIN)
- Balance adjustment (only for CMA type) less than G2.5 / 30000min⁻¹
- *Please order by adding "BL" to the end of the code. (Ex. : HSK63-CMA25-175 BL)

Note

- NT type is available for BT/CAT. and DIN spindle by changing the retention knob.
- HSK type is available for both HSK-A and HSK-E spindles.
- HSK-F type is available only for HSK-F spindle.
- A special design retention knob is required for CAT./DIN spindle.
- A market standard retention knob for ANSI/DIN/ISO is not available. Contact us for detail.
- Use a market standard retention knob for the BT spindle.
- NT30 type can be installed into a spindle at 0° and 180°.

Caution

- A.T.C is not available. (except for NT30)

Exclusive retention knob

CODE	Shank
P-576	CAT. 40
-575	CAT. 50
-578	DIN40
-577	DIN50



Goo CHECKER ZPM type

Set up the original point on the Z axis / measuring tool for reference position

**Shareable Z-axis origin for multiple machining centers.
Easy work-piece origin setting.
Precise work-piece flatness and step measurement possible!**



Easy Z-axis origin setting

Easy measurement for Z-axis origin to work-piece datum surface.

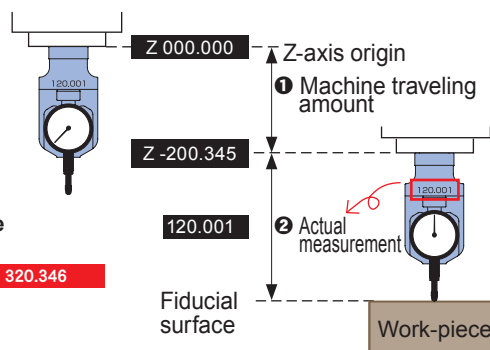

(Ex.)
Distance from Z-axis origin to work-piece datum surface.

$$200.345 + 120.001 = 320.346$$

- ① Machine traveling amount
- ② Goo checker absolute length

Shareable Z-axis origin for several machining centers

After measuring the distance from the Z-axis origin to the table surface of each machining center and correcting any variations, multiple machining centers can share the tool holders and programming.

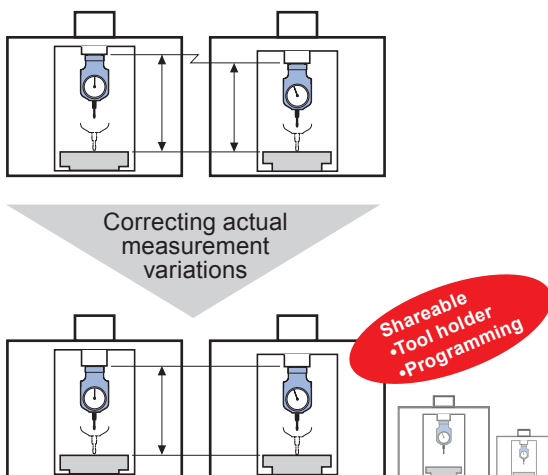

Flatness check

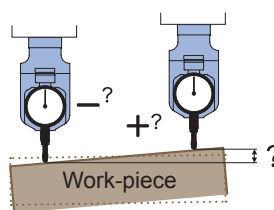

Step measurement

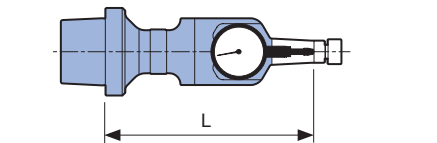
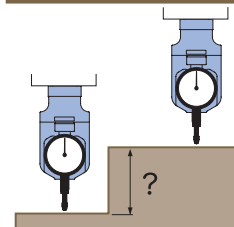

CODE	L	Kg
BT30 -ZPM-130	130	1
-165	165	1.2
BT40 -ZPM-150	150	1.3
-210	210	1.5
BT50 -ZPM-180	180	2.9
-240	240	4.1
A63 -ZPM-150	150	1.2
-210	210	1.5
A100 -ZPM-180	180	2.5
-240	240	3.8
E32 -ZPM-120	120	0.7
-165	165	1
E40 -ZPM-120	120	0.8
-180	180	1.1
E50 -ZPM-150	150	1
-195	195	1.3
F63 -ZPM-150	150	1.1
-210	210	1.3
F80PD-ZPM-180	150	1.1
-240	210	1.3
DN40 -ZPM-150	150	1.3
DN50 -ZPM-180	180	2.9
CT40 -ZPM-150	150	1.3
CT50 -ZPM-240	240	4.1

- Option
 - Retention knob(BT/ CAT./ DIN) → P.216
- Std. Access.
 - Master block ● Indicator, 1/1000 reading
- Caution
 - A.T.C is not available. (except for BT30)

Watch the video and you'll be ready to carry out maintenance immediately!



Removing dents and scratches restores the high accuracy.

Comes with tools

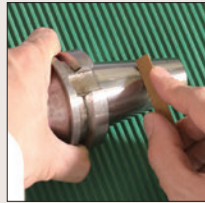
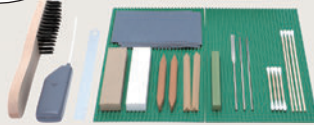

Tool holder



Fixture

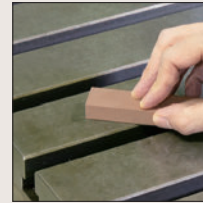

Machine table



Work-piece

Contents

1. The negative influence of dents, scratches and rust.
2. Practical ways to remove dents, scratches and rust - Tool holder edition.
3. Practical ways to remove dents, scratches and rust - Machine table, Fixture edition.
4. Introduction of tools.

PR Movie



Basic Kit

CODE

MTN-BSK1



MTN-MV1



Contents of kit

Tools	Specification	Q'ty
Maintenance DVD	DVD	1
Oilstone-Both ends tapered type	#500	2
-Triangular type		2
-Square type		1
-White type	#3000	1
Rubber grinding stone-Square type	#320	1
Diamond file-Flat type	#120	1
-Round type		1
-Triangular type		1
Wire brush	Hardened steel wire	1
Water-resistant Sandpaper	#1000	10
Cotton-tipped stick-Long type	-	10
-Short type		10
Scraper for clearance gap		1
Light	AA battery×2	1
Mat for work	Rubber mat	2
Kit case	-	1

Note

- Can be sold individually.

Replacement tool set

CODE

MTN-RSS1

Option

- Oilstone-Both ends tapered type(2pcs.)
- Oilstone-Triangular type(2pcs.)
- Water-resistant Sandpaper (10sheets)
- Cotton-tipped stick-Long type (10pcs.)
- Cotton-tipped stick-Short type (10pcs.)



Oilstone-Both ends tapered type



Oilstone-Triangular type



Water-resistant Sandpaper



Cotton-tipped stick-Long type



Cotton-tipped stick-Short type

Single unit

CODE	Q'ty
MTN-MV1	1
MTN-OS1	1
-OS2	1
-OS3	1
-OS4	1
-RS1	1
-DY1	1
-DY2	1
-DY3	1
-WB1	2
-WP1	20
-MB1	100
-MB2	100
-SS1	1
-HL1	1
-MS1	2
-KC1	1

MTN-OS1

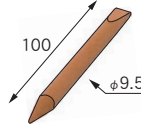

-OS2

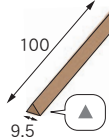

-OS3

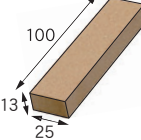

-OS4

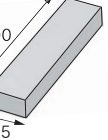

MTN-RS1

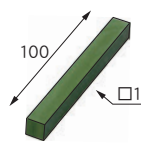

-DY1

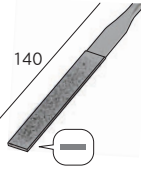

-DY2

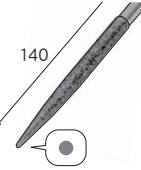

-DY3



MTN-WB1



-WP1

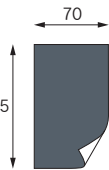

-MB1



-MB2



MTN-SS1

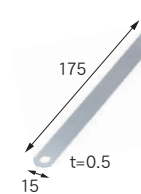

-HL1



-MS1

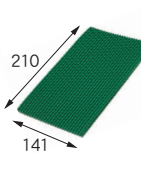

-KC1



Anti-rust oil set

CODE

MTN-ARS1

Contents

- Anti-rust oil
- Anti-rust oil (Refill)

Note

- Can be sold individually.



Anti-rust oil

CODE
MTN-AR1



Anti-rust oil (Refill)

CODE
MTN-AR2

At MST, we provide long-term support of your safe use and maintaining high accuracy of our products for your machining.

1 Pre-sales Provide wide-ranging technical support.



Tool selection

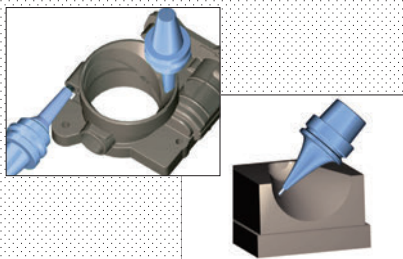

Interference check with 3D drawings

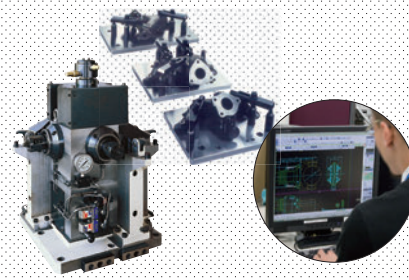

Designing manufacturing fixtures

2 On delivery You will receive instructions.



Instructions for a heater

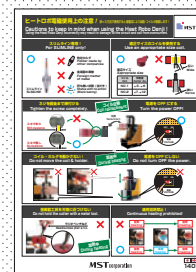

Maintenance instruction

3 Post-sales Our Tool Clinic experts can visit your factory to demonstrate the correct usage, maintenance and seminar.



Seminar



Evaluation



Consulting

We offer a full line-up of peripheral equipment to improve the work environment at your factory.

<p>Work table 6S DESK ➔ P. 220</p>	<p>Holder, Tool washing machine CLEAN BOX ➔ P. 221</p>	<p>Tool protection cover TOOL CAP ➔ P. 222</p>	<p>Cutter protection box ENDMILL HOUSE ➔ P. 223</p>	<p>TOOL HOLDER STORING CABINET ➔ P. 224</p>
		<p>Tool tightening stand TOOL SET UP STAND ➔ P. 225</p>	<p>Cleaning tool for a spindle taper hole STAR DUST ➔ P. 226</p>	<p>For machine spindle maintenance TEST BAR CHECKMATE ➔ P. 227</p>

Feature
Shrink-fit Heater
MONO 3° MONO CURVE
MONO Series
2PIECE type
UNO
HYPER version
STRAIGHT anbor
OTHERS
PERIPHERALS
Technical Information

Instructions for use

To ensure optimum, trouble-free performance, please read this instructions carefully before using products.

Please contact us if your holder is damaged. We are ready to help you.

Instructions for using SLIMLINE

Pay attention to scratches and dust.

Before using, be sure to remove anti-rust oil on the holder. Scratches and dust can reduce performance and accuracy. Please keep your holders clean with rags. Our CLEAN BOX is available for your cleaning needs.

Holder, Tool washing machine
CLEAN BOX
→ P.221



Tool holder shank

If you insert holder shanks with scratches and dust into machine spindles, the accuracy of the spindle is reduced and the spindle can be damaged. For shank maintenance, use an oil grinding stone or sandpaper to remove scratches and rust. We can not re-grind shanks since it changes the position of gauge line, so we recommend you to purchase new holders.



Storage

Please use tool protection covers if you store holders with cutters. Cutting edges may be damaged by coming in contact with each other, and you may get injured by sharp cutting edges.



Tool protection cover
TOOL CAP
→ P.222



Daily maintenance

Why does rust form?

- Water in air adheres to SLIMLINE holders. This water reacts with the metal and then rust forms. Since the SLIMLINE is heated, the oil on its surface is liable to evaporate and this makes rusting more likely to occur.
- Rust formed on the metal surface gradually corrodes deeper over time.

Coolant-through-spindle

In particular, when coolant is passed through a holder or a collet in the spindle-through system, it remains deep inside the holder and induces rusting.

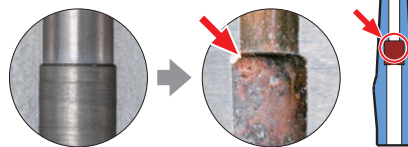

Flush type

Special care must be taken for the flush type SLIMLINE, because coolant is more likely to remain in its small holes.

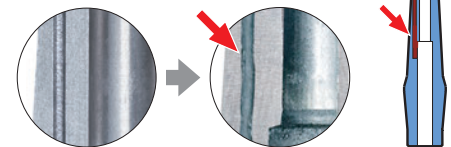

What happens after rusting?

- If a tool is chucked in this state, the tool cannot be inserted into the holder. If the tool is forced, then the stress resulting from the shrink-fit will focus on the corroded part and it causes the holder to crack.
- The clamping force is reduced, resulting in cutter slippage and loss of accuracy.

Create cracks

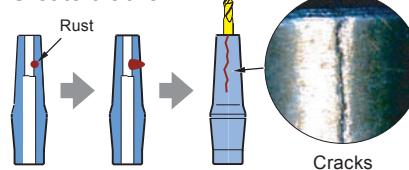

Internal bore distortion of the cutting tool

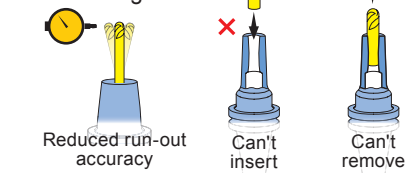

What should be done to prevent rusting?

Iron rusting occurs if there are water content and air (oxygen). It can be prevented by removing water content by rustproofing or by ensuring that the metal is not directly exposed to air (oxygen).

1 Cleaning (removing water content)

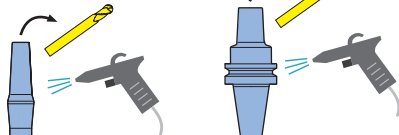

- After use, blow off any clinging water content with compressed air. Sufficiently blow air, in particular, into the deep ends of holes, small holes in the flush-type SLIMLINE, etc. After SLIMLINE has been cleaned with cleaning oil or a washing machine, blowing the holder with compressed air is effective.
- Heat SLIMLINE with a shrink-fit heater and then remove the cutting tool.

2 Rust proofing

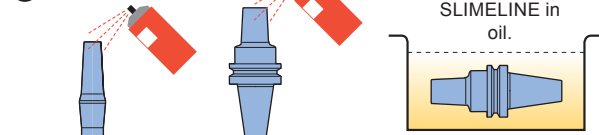

- After cleaning, spray with rustproofing oil or immerse your SLIMLINE in rustproofing oil.
- Prior to shrink-fitting, sufficiently remove the rustproofing oil remaining on the SLIMLINE. To remove the oil, a cleaner spray or solvent is useful.

If it's getting hard to insert the cutting tool?

If oxidation has occurred, or grease or dust has burned onto the internal bores, remove with "cleaning tool rubber grinding stone".

Cleaning tool
Rubber grinding stone type
→ P.17

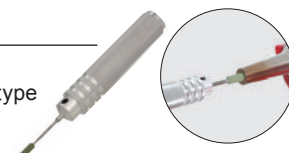

Precautions for shrink-fitting

Cleaning before shrink-fitting

You must clean the cutter shank and internal bore of holder before you shrink-fit it. Please use our brush-type cleaning tool to clean out dust and dirt inside before you shrink-fit.



Cleaning tool
Brush type → P.17

Usable tools

- Please use only carbide cutters. No shrink release is possible for any tool using high-speed steel.
- A tool exceeding its tolerance can cause breakage or slippage.
- Sometimes melted particles such as tiny cutting chips on cutter shanks get stuck in clamping holes, and cutters can't be removed. DO NOT remove or insert the cutting tool forcibly, when you cannot remove it, please reheat again.

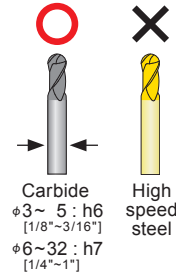

Using heat-resistant gloves

Use these gloves to protect from burns during operation.



Heat-resistant gloves
→ P. 16



Retention knob (BT)

Use a retention knob that has a through hole, or remove the retention knob and heat it. The typical retention knob has no vent to release air which prevents tools from being inserted.

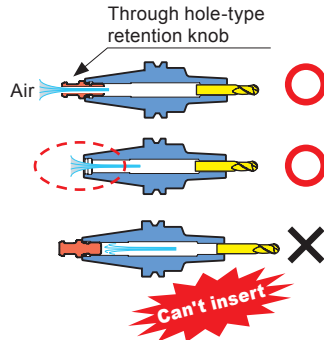

Through hole-type retention knob

Coolant duct (HSK-A)

When you use hot air heater, remove the coolant duct before heating the holder. If you heat the holder with the coolant duct attached, the O-ring will be damaged. A dummy duct is available. If you don't use the coolant-through feature and don't want to remove the duct every time.

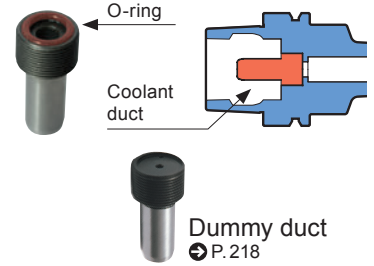

Max. insertion length

Inserting the cutter all the way to the bottom of the holder may result in insufficient accuracy. Please ensure the insertion length.

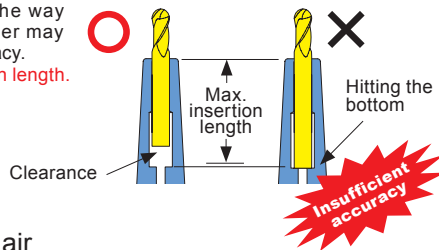

Min. holding length

A short insertion length may cause the holder to be damaged when the cutter is inserted. Always insert the cutter shank beyond the safety mark.

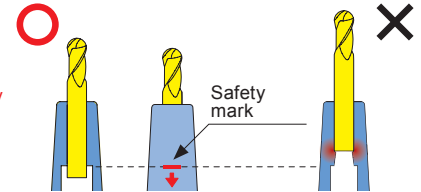

Cooling by outside air

Do not directly apply air to the shrink-fitting heater when cooling the hot-air heater (HRB type) using air from the outside. The fan in the heater will melt, resulting in a breakdown.

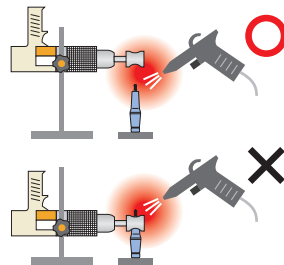

Precautions for water-cooling

Water-cooling immediately after shrink fitting may result in burns due to the large quantity of steam generated. Be sure to set the shrink-fitting heater setting to COOL and cool the holder for at least one minute before water-cooling. Moisture left on the holder may lead to rust formation and damage to the holder, so be sure to completely remove all moisture.



2 PIECE type : When the SLIMLINE collet can't be removed from the master holder.

Tap the collet. You can remove the collet after loosening the stuck screw.

- 1 Remove the tool using a shrink-fit heating device.
- 2 Apply force once using the dedicated wrench in the eject direction.
- 3 Tap it.
- 4 Eject.
- 5 Apply oil to the thread.



<p>Regular type Flash type (CR/CRB/CF)</p> <p>2.25~6</p> <p>Copper hammer</p> <p>Copper plate or aluminum plate</p> <p>Flat, thick steel plate</p>	<p>Slim type (CS)</p> <p>1.5</p> <p>Steel pipe L=Longer than(M) φC=Bigger than(φC₁) and smaller than (φ26)</p> <p>※Refer to code list for (M) and (φC₁).</p> <p>Steel pipe</p>
--	--

The reason it cannot be loosened.

In most cases, there is not adequate lubrication on the thread.

Low oil content

※Please contact MST if you cannot remove a collet using the method above.

Cautions when using the HEAT ROBO DENJI (HRD-01S, HRD-02SH, HRD-03)

Only for use with SLIMLINE holders

Use of the following items will lead to damage to the heater from excessive current.

- Other brand's shrink-fit holder
- Foreign matter made of metal
- Heating without a shrink-fit holder (blank heating)

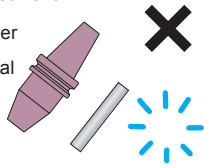

Attaching an air filter

For air-cooling, use filtered air. Air with a lot of water, or hot air, can break air component parts.

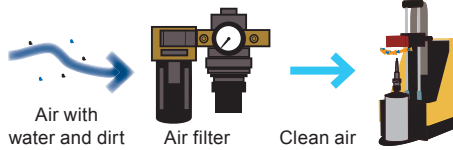

Do not use steel hand tools

Wear heat-resistant gloves and use a cutter stopper.

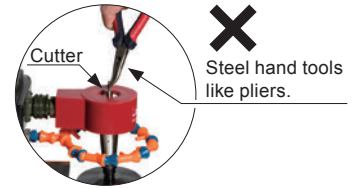

Changing coils... Be sure to turn off the power

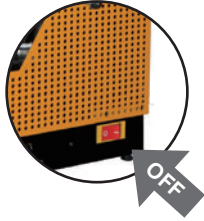

Use the appropriate coil size (HRD-01S, HRD-02SH)

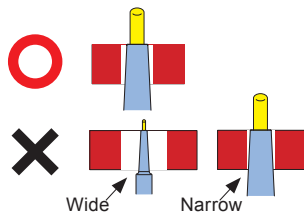

Do not repeat heating

Always conduct a cooling operation for at least one minute after a heating operation, as continuous heating may damage the unit.

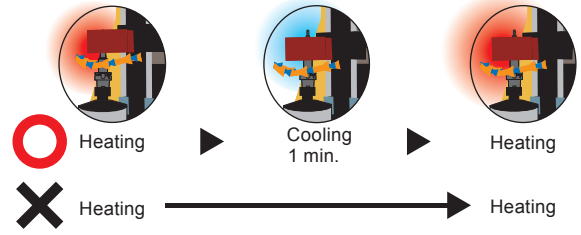

When you attach a coil, tighten the threaded connector all the way. (HRD-01S, HRD-02SH)

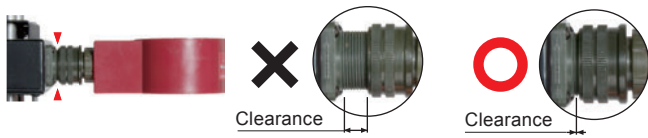

Heating

Do not turn OFF the power.

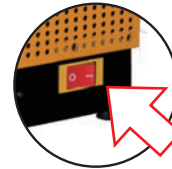

Do not move the coil & holder.



The HEAT ROBO DENJI 1200S (HRD-01S) is unable to shrink certain holders

For the MONO series and STRAIGHT ARBOR, please check for compatibility on item code table before using your holders. For those marked with [▲] on the table, please follow the procedure to the right.

Compatibility table for HRD-01S

[○] Available [×] Not available
[▲] Usable by raising the heating unit. → P. 233

	Kg	N	S
	1.0	2.3	9.1
	1.1	3.1	14.6
			○
			▲

Code table

BT shank

Remove the positioning plate and raise up the heater with a block.

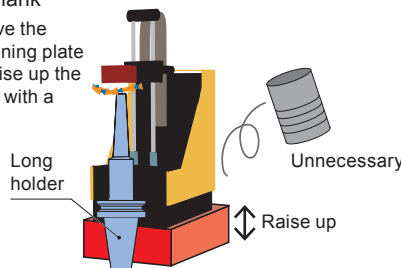

HSK shank

Set up the holder on the positioning plate directly.

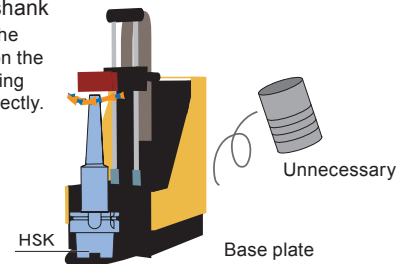

User customization (Additional processing)

- Do not change the overall length (tool clamping length).
- Ensure that a thickness of at least 1.5mm is maintained.
- The custom machining area must be above the [▶] mark. Please check details on the code tables.
※ For the machining area of the STRAIGHT arbor, see the operation manual.
- You can not do custom machining with the STRAIGHT ARBOR Carbide Shank type.
- When customizing flush-type (CF, SLFA and SLFB) holders, pay particular attention to the coolant-through holes.
- On request, we also supply drawings as CAD data (DXF format), which are useful for additional processing. These drawings may also be used to carry out interference checks with the work-piece and fixtures.
- The rigidity of the holder decreases after custom-machining. Reduce cutting conditions when using it.

MONO 3°

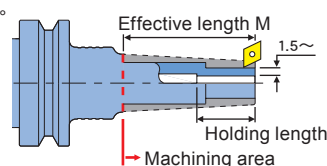

2 PIECE type

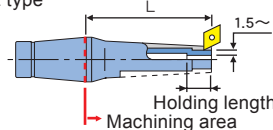

STRAIGHT arbor

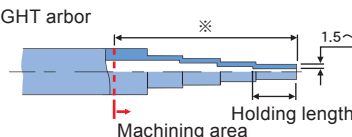

About custom-machining (turning)

- Perform light cutting using a shallow cutting depth (0.1 to 0.2mm).
- During cutting, use water-soluble coolant and do not allow the temperature of the object being cut to rise.
- Use a stainless-steel tool or positive tip tool.
- The following machining conditions are recommended:
 - Cutting speed ... 30~50m/min
 - Feed rate ... 0.1~0.2mm/rev
 - Cutting depth ... 0.1~0.2mm

Rigidity of SLIMLINE

Relationship between SLIMLINE rigidity S and L/D

SLIMLINE has a very slim design. Your cutting results may vary significantly, depending on the holder design and the cutting tool projection length.

Rigidity Value S in the dimension tables can be used as a reference mark when selecting holders. Please refer to the example below to learn more about this.

h	Kgf	N	S
50	4	6.6	9.2
30	3.9	8.2	
	4.3	8.5	11.1
	3.3	3.4	10.4

(Code table)

Rigidity Value S is the deflection amount of a holder with a 3D cutter projection length

① SLIMLINE MONO 3°

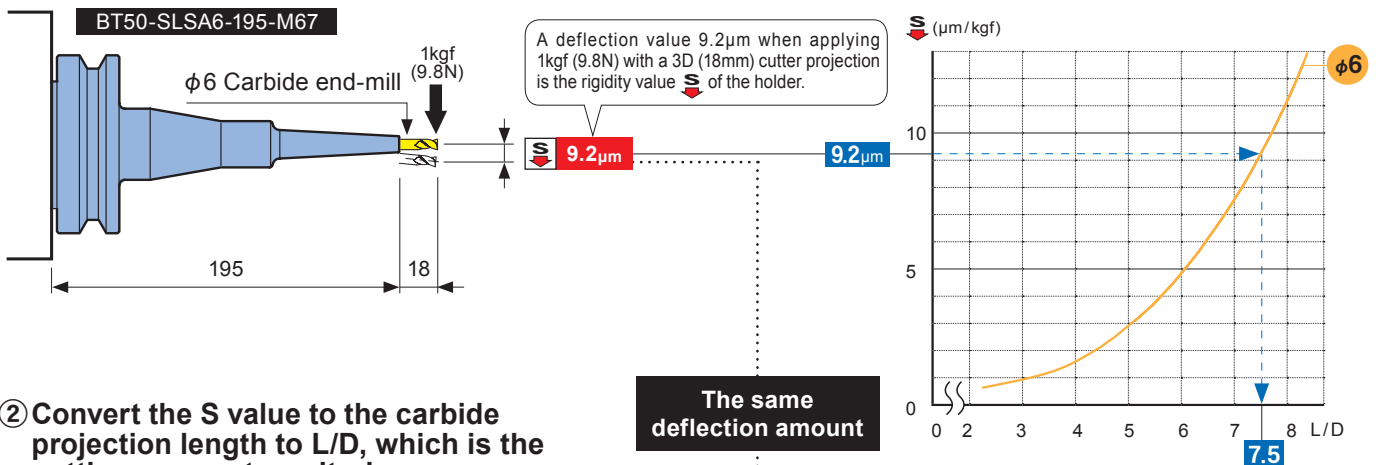

② Convert the S value to the carbide projection length to L/D, which is the cutting parameter criterion.

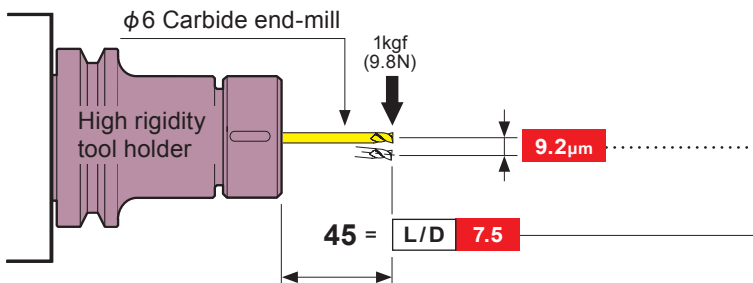

The rigidity value $S = 9.2 \mu\text{m}$ for BT50-SLSA6-195-M67 (18mm cutter projection) is equivalent to $L/D = 7.5 = 45\text{mm}$ of carbide cutter projection.

③ Even if the holder lengths are the same, the rigidity can vary greatly due to differences in the holder design.

Selecting the same length MONO Curve BT50-SLSA6-195cv holder will give a rigidity value of $S = 3.6 \mu\text{m}$, $L/D = 5.5$, enabling more stable machining.

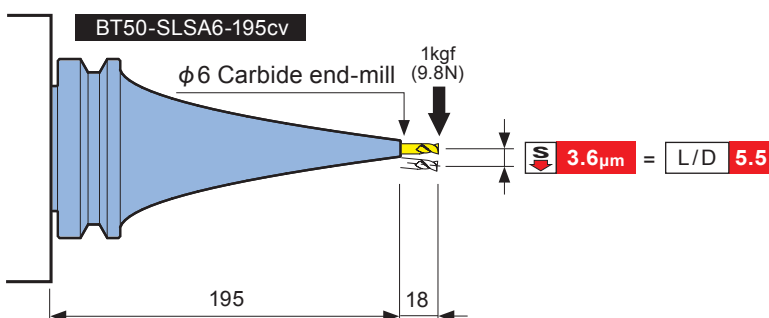

SLIMLINE rigidity calculation software

Please use our SLIMLINE rigidity calculation software for different cutter lengths (excluding 3D) and stepped/tapered cutters. It will calculate the rigidity according to your machining conditions.



➔ P.236

The graph of relationship between rigidity S and L/D

The values of L/D can be determined based on the rigidity S value.

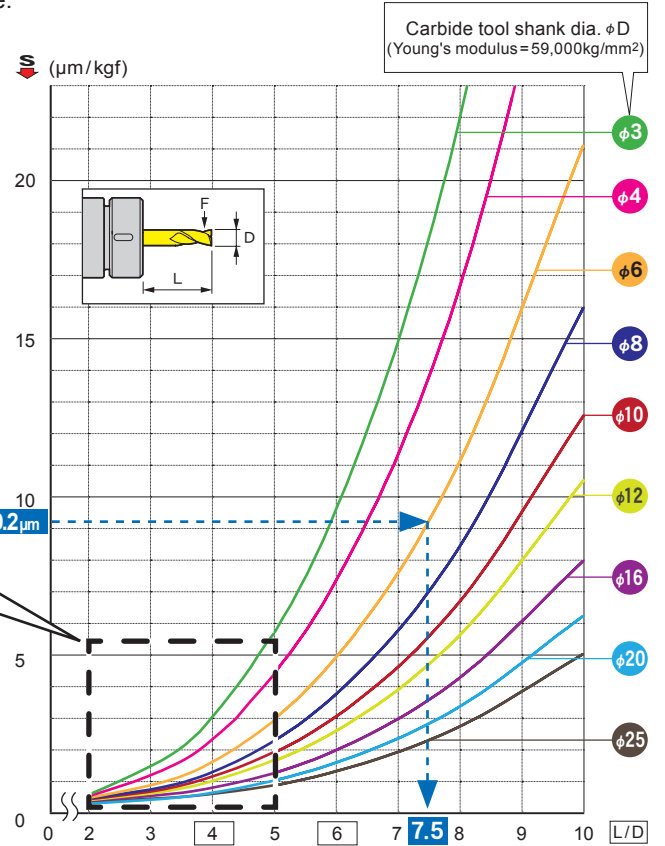
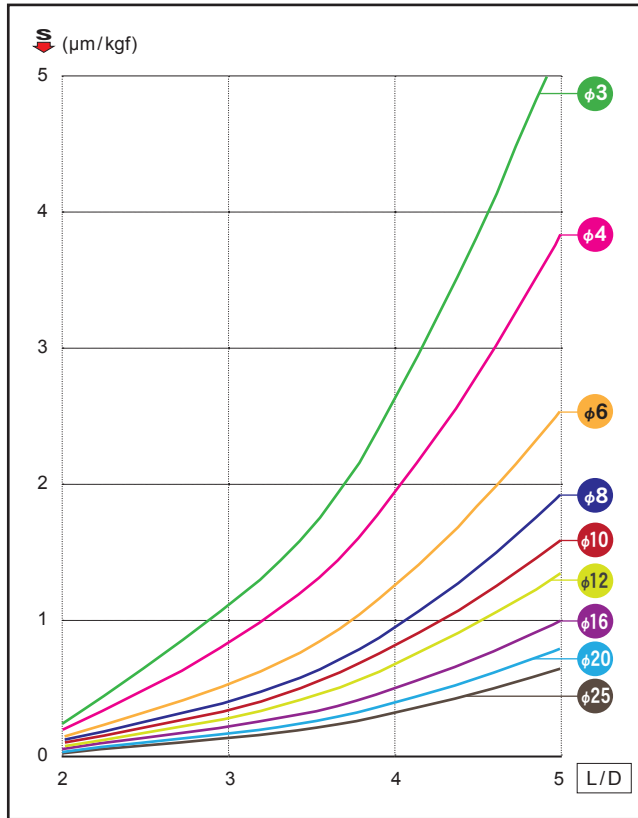

The formula to determine rigidity S (Deflection)

$$S = \frac{6.8 \times F \times L^3}{E \times D^4}$$

D : Tool shank dia.
 L : Overhang length of cutter
 F : Load
 E : Young's modulus

Cutting condition indication

	Cutting condition	
	Standard	Need to consider
Square end-mill	L/D=4 Less than	L/D=4 Over
Corner radius end-mill	L/D=4 Less than	L/D=4 Over
Ball end-mill	L/D=6 Less than	L/D=6 Over

Productivity comparison and surface finishing quality by different carbide cutter lengths (L/D)

Machinability

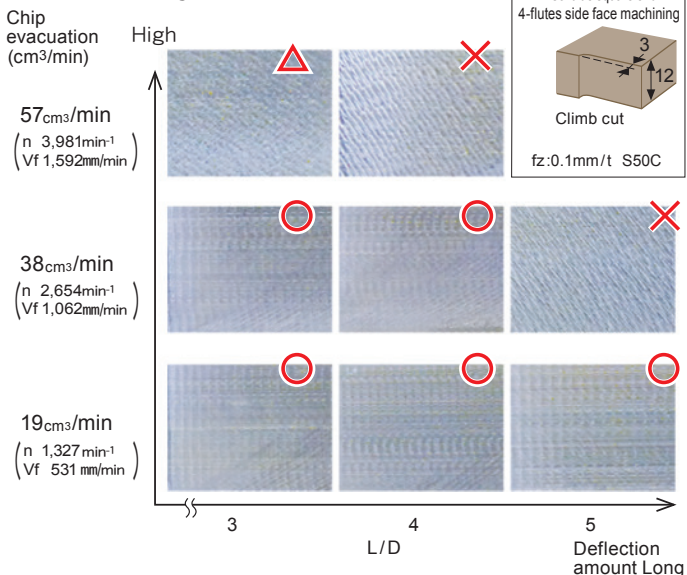

Finishing surface (R_z)

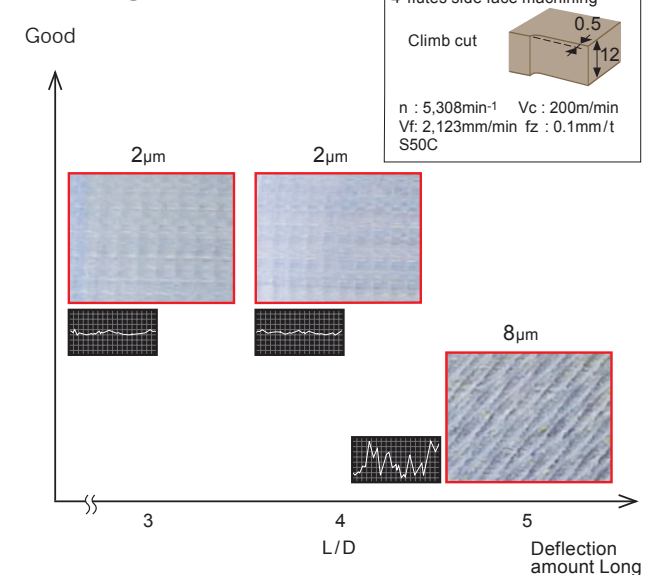

SLIMLINE RIGIDITY calculation software

Free of charge

Indispensable for CAM operators!

PAT.

Do you have similar problems?

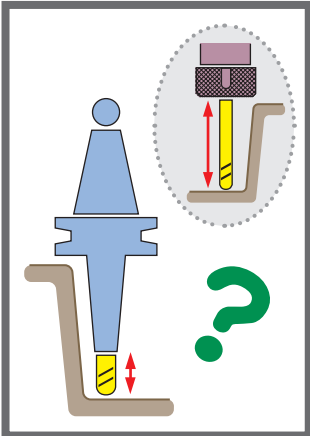

How much more rigidity is there in SLIMLINE compared to conventional holders?



We are looking for SLIM-LINE products(4,000 Variations)that can be used at even higher cutting conditions.

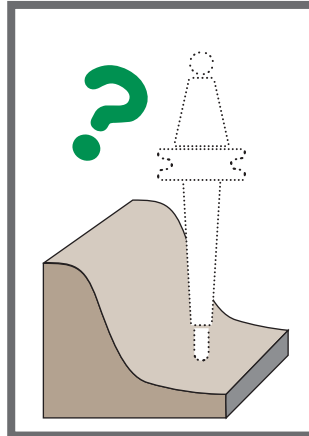

We want a holder that perfectly matches our cutting conditions and the shape of our workpiece.

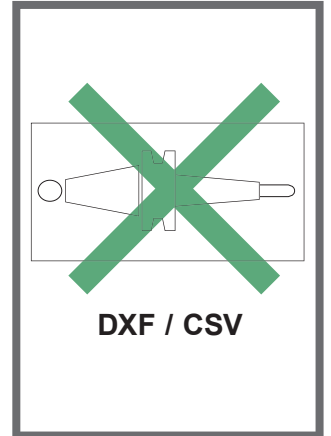

There is no drawing data, which makes it troublesome for us to carry out an interference check using CAM.

Solution



Use SLIMLINE Rigidity Calculation Software to easily check SLIMLINE rigidity with cutter and work-piece interference. You can select the optimum holder with stronger rigidity and less interference.



High rigidity

You can readily improve your machining efficiency and quality.

- The most suitable SLIMLINE +
- Cutter +
- Cutter projection

- ④ Displaying the main dimensions
- ③ The most suitable SLIMLINE holder with the highest rigidity for the shape of the work piece is automatically selected.
- ⑤ "Selected SLIMLINE holder" with optimized "projection" of "cutter" can be output in DXF/CSV.
- ② Holders are listed in order of rigidity.

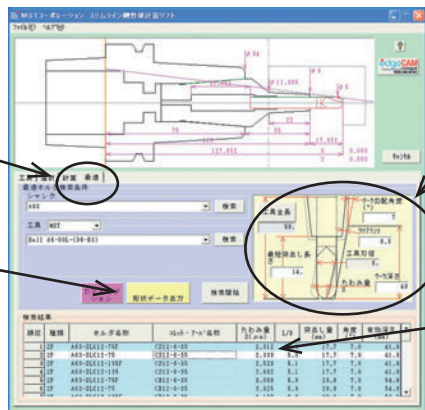

① Input a work-piece geometry. Input clearance information (between a work-piece and tool/holder), and tool overhang limitation (min. value).

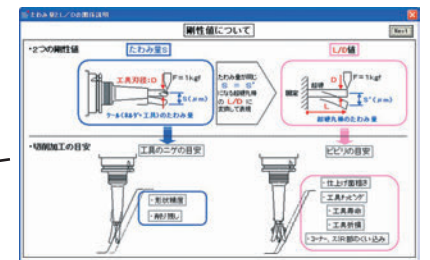

•The CAM simulators listed below come with SLIMLINE configured data as a standard.

CAM-TOOL CAM-TOOL	edgcam EDGE CAM	worknc WORK NC	hyperMILL 5 AXIS HYPER MILL	JBM Engineering JBM Engineering	GENETEC GENETEC	SIEMENS Siemens PLM Software
FF/cam FF/cam	tebis THE CAD/CAM EXPERTS TEBIS	AUTODESK POWERMILL PowerMill	CADmeister CAD meister	VISI VISI	VERICUT VERICUT	SAEILO SAEILO JAPAN

※CAUTION : Each set of geometry data is handled differently, so please ask each CAM manufacturer for help.

For high-speed spindle rotation

Imbalance value of a machine tool spindle and a tool holder

A tool holder imbalance value (G grade) focuses at high-speed spindle rotation of a machining center. However, it is important to consider the entire rotation body, including the spindle, holder and cutter to determine the high-speed spindle rotation. This is because the holder and cutter weight is much lighter than the spindle weight (less than approx. 1/20th), and thus the effect of a tool holder on the spindle rotating equipment (spindle, tool holder and cutter) becomes significantly smaller.

Spending time and money on balance corrections to the holder alone will not result in significant improvement.

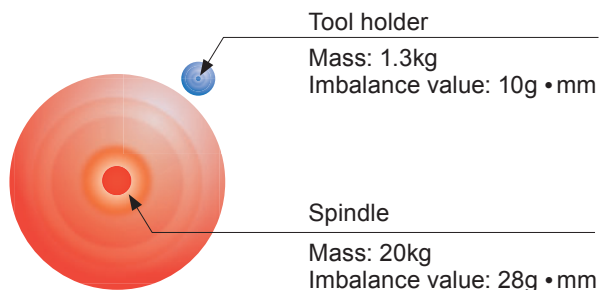
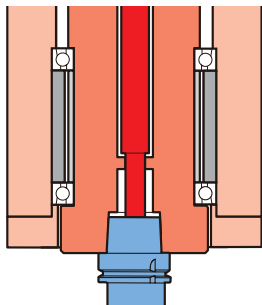
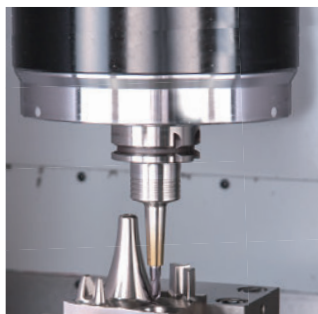

Achieving high-speed, high-efficiency machining requires more than just good balance.

- What is the run-out accuracy of the machine spindle, tool holder and cutting tool?
- Is there taper contact between the machine spindle and tool holder?
- What is the diameter of the cutting tool?
- What is the cutting speed? Spindle rotation?

MST considers these points carefully and produces a tool holder according to our own pre-balanced design concept.

Pre-balanced design

MST has applied our original pre-balancing to make the tool holders applicable for high-speed spindle rotation. Balancing corrections for our products is not required.

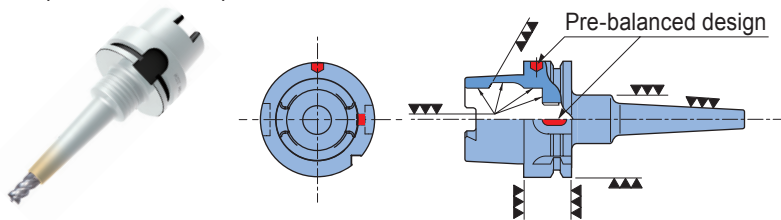

- Counter-balancing at imbalanced design areas.
- O.D finish grinding after heat treatment.

Unbalancing in terms of tolerable residual ration against the balancing grade(G grade value)

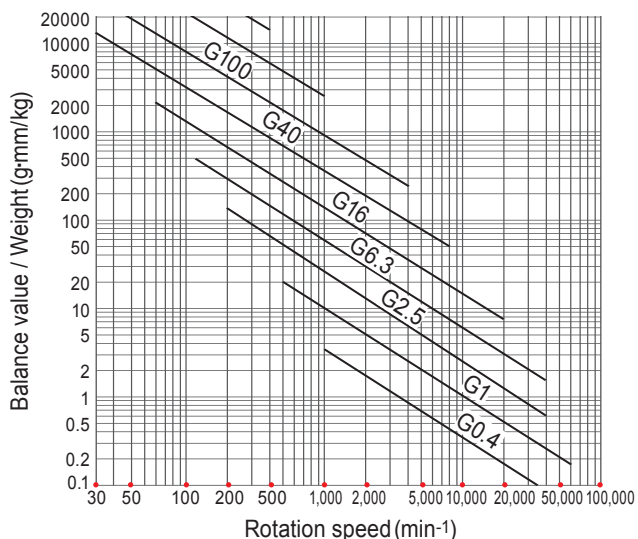

Points to keep in mind at high-speed rotation.

- Minimal length of a tool holder and cutting tool as short as possible.
- Using high accuracy and compact design tool holders.
- Optimizing cutting condition(rpm, feed and depth of cut).

Relationship between a cutter diameter and spindle rotation

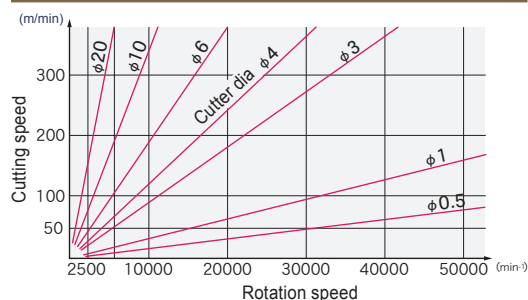

<<Reference >>

Recommend various of G grade of a rotating body

G grade	G	Rotating body
G40	~ 40	The car wheel
G16	~ 16	The parts of agricultural machines The parts of truck
G 6.3	~ 6.3	Machine tools and aviation gas- turbine rotors after assembling general mechanical parts
G 2.5	~ 2.5	The spindle of machine tool Gas turbine Steam turbine
G 1	~ 1	The grinding wheel spindle of grinding machine
G 0.4	~ 0.4	The grinding wheel spindle of precise grinding machine Gyroscope

Determining tool holder G grade

$$G = \frac{\text{Imbalance value(g•mm)}}{\text{Weight (kg)}} \times \frac{\text{Spindle rotation speed}}{9,550}$$

Holders for high-speed operation include "Imbalance value" and "holder weight" columns in the dimensions table.

Determining G grade of rotating equipment

$$G = \frac{(\text{Spindle} + \text{Holder} + \text{Cutter}) \cdot \text{Imbalance value(g•mm)}}{(\text{Spindle} + \text{Holder} + \text{Cutter}) \cdot \text{Weight (kg)}} \times \frac{\text{Spindle rotation speed}}{9,550}$$

Application examples using SLIMLINE

The shrink fit quill for an internal grinder

A SLIMLINE holder has a slim design. It minimizes interference with grinding wheel. It holds the shorter portion of the tool for grinding. Grinding can be performed with high accuracy and high rigidity. It reduces tool costs and contributes to cost reduction.

Current method of chucking with a collet

■While setting-up

- It does not achieve good run-out accuracy.
- Centering process is required.

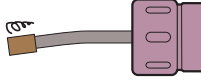

■While grinding

- Poor machining accuracy
- A grinding wheel deflects during deep internal bore grinding.
- Tool life is short.

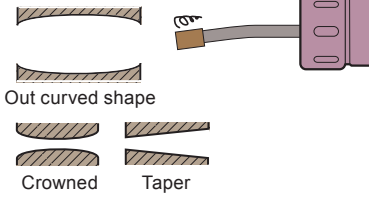

Problem resolution

Ideal for internal grinding. Comparison data

Measurements	SLIMLINE	COLLET HOLDER
Roundness	0.3 μm	0.6 μm
Surface roughness(R _a)	1.38 μm	2.7 μm

Improves grinding accuracy

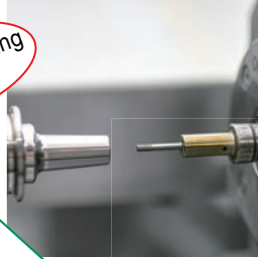

3 μm

Strong clamping force

The shrink-fit quill for an internal grinder



Specialized brochure available

Tool grinding applications

The chucking accuracy of a grinding wheel largely influences grinding accuracy (roundness and surface roughness, etc.). A shrink-fit quill SLIMLINE holder further enhances processing accuracy.

Examples of improvements

Interference

Problem resolution

SLIMLINE

Less interference

Best suited for regrinding

Grinding wheel

SLIMLINE

- Cutting tool life is shortened.
- Tool cost runs up.
- Bad machining conditions.

- Improvement tool life.
- Tool costs are decreased.
- Increased cutting speed!

Short-overall length carbide endmill for shrink-fit holders.

With a SLIMLINE, the maximum insertion length is short, so a normal length tool is not necessary.

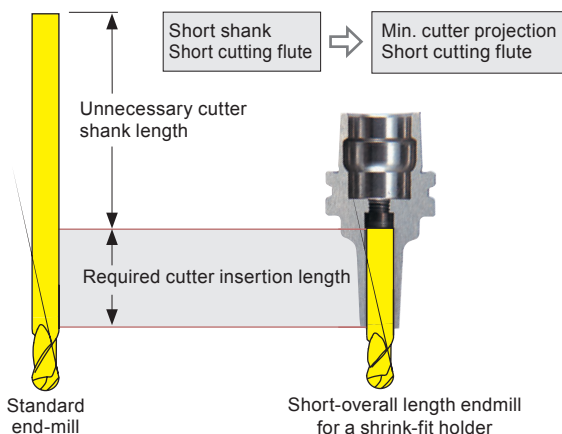

<p>DIJET</p> <p>Super short ball end mill</p> <p>DZ-SSB</p>	<p>MITSUBISHI MATERIALS</p> <p>Impact miracle ball end mill</p> <p>VF-2SSB</p>	<p>MOLDINO The Edge To Innovation</p> <p>Shrink master ball</p> <p>FSHB-TH</p>
<p>NS TOOL</p> <p>Short shank ball end mill</p> <p>MSB230SF</p>	<p>GSI</p> <p>Short over all length type WXL end mill</p> <p>WXL-HS-EBD WXL-HS-LN-EBD</p>	<p>UNION TOOL</p> <p>High-efficiency short shank ball</p> <p>HFB-S HSB-S HSLB-S</p>

Cutting data

BT40-SLK12-45
CF12-3-55

n : 20000 min⁻¹
Vf : 2000 mm/min
Vc : 25 m/min
fz : 0.05 mm/t

R0.2 Carbide ball endmill
2 flutes

User's voice
Cutter life was extended almost double, because chucking accuracy was improved. Finishing surface of work-piece was improved.

SKD61(50HRC)

BT40-SLK12-45
CR12-6-55

n : 15000 min⁻¹
Vf : 2400 mm/min
Vc : 188 m/min
fz : 0.04 mm/t

φ6 Carbide endmill
2 flutes

Cutter life was extended almost double against a collet holder. Scratch on the cutting surface with up-cut operation has been disappeared due to increasing rigidity of a cutting tool, because of reducing cutter projection when using SLIMLINE.

Sintering

BT50-SLK12-75
CS12-10-55

n : 6000 min⁻¹
Vf : 6000 mm/min
Vc : 188 m/min
fz : 0.5 mm/t

R5 Carbide ball endmill
2 flutes

We achieved sufficient cutting surface. Cutter life was extended about 3 times against using a collet holder.

SKD11(40HRC)

A63-SLK12-75
CF12-6-55

n : 16000 min⁻¹
Vf : 3200 mm/min
Vc : 301 m/min
fz : 0.1 mm/t

R3 Carbide ball endmill
2 flutes

Cutter life was extended about 3 times due to superior chucking accuracy. SLIMLINE provides us great cutting surface, therefore, we could reduce hand-polishing time.

S55C(28HRC)

A63-SLK12-75
CS12-6-80

n : 20000 min⁻¹
Vf : 4000 mm/min
Vc : 377 m/min
fz : 0.1 mm/t

R3 Carbide ball endmill
2 flutes

No necessity long time for checking interference. Spindle rotation and feed rate were increased 1.5 times. Cutter life was extended due to superior chucking accuracy.

A7075

A63-SLK12-75
CF12-10-55

n : 20000 min⁻¹
Vf : 6000 mm/min
Vc : 628 m/min
fz : 0.15 mm/t

R4 Carbide ball endmill
2 flutes

SLIMLINE provides constant run-out accuracy. We achieved sufficient cutting surface, because of vibration free machining due to high rigidity for cross feed. Cutter life was extended 1.5 ~ 2 times against a collet holder.

SKD11(50HRC)

A63-SLK12-75
CR12-10-55

n : 20000 min⁻¹
Vf : 6000 mm/min
Vc : 628 m/min
fz : 0.15 mm/t

φ10 Endmill
2 flutes

SLIMLINE achieves noise less running at high speed spindle rotation. No required long projection of cutting tool, because SLIMLINE compact design provides us superior approach to cutting point without interference against work clamping devices.

AL5

A100-SLK12-105
CR12-4-55

n : 13000 min⁻¹
Vf : 700 mm/min
Vc : 61 m/min
fz : 0.03 mm/t

φ4 Carbide taper endmill
(1°) 2 flutes

Cutter life was extended 2 times against a conventional collet holder due to superior chucking accuracy.

HPM7(32HRC)

BT40-SLSA6-95-M42

n : 2000 min⁻¹
Vf : 100 mm/min
Vc : 38 m/min
fz : 0.025 mm/t

φ6 Carbide endmill
2 flutes

Cutting surface and holding accuracy improved.

ADC12

BT50-SLRB20-110-M42

n : 4500 min⁻¹
Vf : 4400 mm/min
Vc : 283 m/min
fz : 0.489 mm/t

R10 Carbide ball endmill
2 flutes

We doubled the z feeding compared to conventional holder, but this holder still has enough rigidity.

Plastic

BT40-SLSB12-180-M127

n : 2500 min⁻¹
Vf : 500 mm/min
Vc : 94 m/min
fz : 0.1 mm/t

R6 Carbide ball endmill
2 flutes

During the cutting process the vibration reduced, and the cutting surface was improved.

Gr

BT50-SLSB16-225-M127

n : 5600 min⁻¹
Vf : 2000 mm/min
Vc : 281 m/min
fz : 0.179 mm/t

φ16 Carbide endmill
2 flutes

Holding accuracy was stabilized. Cutting surface and cutter life improved 2-3 times.

S55C

E40-SLRA6-50

n : 20000 min⁻¹
Vf : 1500 mm/min
Vc : 377 m/min
fz : 0.038 mm/t

R3 Carbide ball endmill
2 flutes

With conventional holder we could not have good surface finish. However with SLIMLINE we could have great surface finish.

SKD11(60HRC)

F63-SLSA4-75-M22

n : 16000 min⁻¹
Vf : 1200 mm/min
Vc : 100 m/min
fz : 0.038 mm/t

R1 Carbide ball endmill
2 flutes

Machining surface quality has been improved thanks to the improvement in cutting tool run-out. This doubles cutting tool life, allowing for an increased feed rate (cutting condition), which reduces machining time.

SKD61(55HRC)

A100-CTH25-195
ST25-SLSA6-320

n : 5000 min⁻¹
Vf : 150 mm/min
Vc : 94 m/min
fz : 0.015 mm/t

Carbide coated endmill
2 flutes

The rigidity and accuracy of the SLIMLINE system has been improved so that it only requires two components (master holder and collet) for chucking a cutting tool while conventional systems require three different holders connected in series. The machining time has been reduced to 300 minutes from 360 minutes.

P x 5

HSK Shank

MST uses DIN-HSK standard shanks, which are widely used in Japan and other countries as “2-face contact tooling” for high-speed, high-efficiency machining.

- ▷ The close contact of the end faces (2-face contact) of the HSK shank results in high rigidity for transverse feed, which minimizes vibrations during machining and improves the operating life of the cutting tool and the finished surface.
- ▷ Even if the spindle expands during high-speed rotations, the tapered hollow portion comes up with that expansion, thereby maintaining high precision.



A type

The most common type in use today.



E type

This type has no drive keyway and is suitable for high-speed machining.



F type

This type uses a combination of different sizes of tapers and flanges.



T type

This type is for turning with multiple machining

Pre-balanced design

The HSK-A-type shank is unbalanced in its standard form, but at MST we have applied our original pre-balancing to make our tool holders applicable for high-speed machining.

In the DIN standard, only the area marked with an asterisk (*) is finished in the hollow. In order to further improve the balance, MST has carried out finish machining after heat treatment.

	MST	DIN standard
A63	15 g·mm	75 g·mm
A100	28 g·mm	170 g·mm

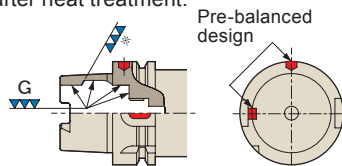

Rigidity comparison with BT shank

The HSK shank is effective when longer overhang or higher transverse feed rigidity is required. The higher rigidity greatly contributes to improving the operating life of the cutting tool and the smoothness of the finished surface.



Coolant duct

This is a coolant feed part exclusively for the HSK-A type. MST's HSK-A type holder comes standard with each coolant duct.

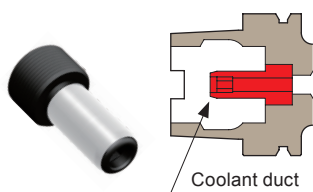

! For some machines, the use of a coolant duct (Adjustable) is recommended. The existing coolant duct is replaced with an adjustable one at your request only when you have placed an order for the holder.

☞ P.218

Three times stronger clamping force

HSK uses a clamping mechanism, which utilizes the wedge effect, to provide a tool gripping power 2.5 to 3.0 times greater than in the pull-stud system (BT40 and BT50), thereby increasing rigidity.

	Tensile strength of draw bar	Tool clamping force
BT40	10~15kN	10~15kN
A63	5.8kN	18.4kN
BT50	20~25kN	20~25kN
A100	14.5kN	45.9kN

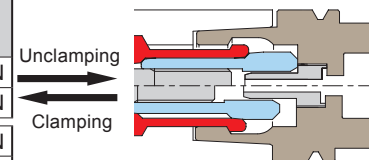

Taper gauge

MST establishes the optimal value within the tolerance in accordance with the DIN standard and manufacturers master gauges for tool shanks and those for spindle tapers accordingly.



HSK-T Tooling Systems for Turning Mill

Collaborative development with 17 Japanese makers has resulted in an interface for mull-turning machines based on the HSK-A type. With its ISO accreditation it has become popular standard around the world.

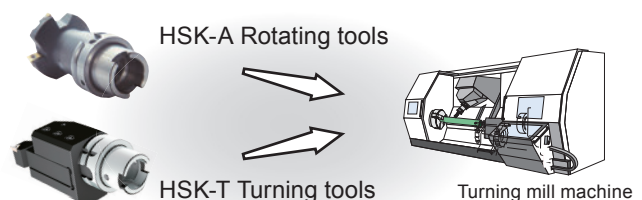

Technical data

The shank dimensions

HSK-A (Extracts from DIN 69893-1;1993-07)

Shank	A40	A50	A63	A100	A125
b1 (H10)	8	10.5	12.5	20	25
b2 (H10)	9	12	16	20	25
b3 (H10)	11	14	18	22	28
d1 (h10)	40	50	63	100	125
d2	30	38	48	75	95
	+0.007 +0.005	+0.009 +0.006	+0.011 +0.007	+0.015 +0.009	+0.018 +0.011
d3	29.05	36.9	46.53	72.6	91.95
	+0.005 +0.003	+0.006 +0.003	+0.007 +0.003	+0.009 +0.003	+0.011 +0.004
d4 (Max.)	34	42	53	85	105
d8 (H10)	21	26	34	53	67
d9 (H11)	25.5	32	40	63	80
d10	23	29	37	58	73
d11	M12×1	M16×1	M18×1	M24×1.5	M30×1.5
d14 (Max.)	5	6.8	8.4	12	14
e1	10.88	13.797	17.862	27.329	35.324
f1 ($-\frac{0}{-0.1}$)	20	26	26	29	29
f2 (min.)	35	42	42	45	45
f3 (± 0.1)	16	18	18	20	20
f4 ($+\frac{0.15}{0}$)	2	3.75	3.75	3.75	3.75
h1 ($-\frac{0}{-0.2}$)	17	21	26.5	44	55.5
h2 ($-\frac{0}{-0.3}$)	12	15.5	20	31.5	39.5
l1 ($-\frac{0}{-0.2}$)	20	25	32	50	63
l2	4	5	6.3	10	12.5
l3	9.5	11	14.7	24	30.5
l4 ($+\frac{0.2}{0}$)	6	7.5	10	15	19
l5 ($+\frac{0.2}{0}$)	3.5	4.5	6	10	12
l6 (JS10)	11.42	14.13	18.13	28.56	36.27
l7 ($-\frac{0}{-0.1}$)	8	10	10	12.5	16
l8 ($-\frac{0}{-0.3}$)	8	10	12	16	18
l12	12	19	21	24	24
r3 ($\pm \frac{0.05}{0.05}$)	1.88	2.38	2.88	4.88	5.88
r8	4.5	6	8	10	5

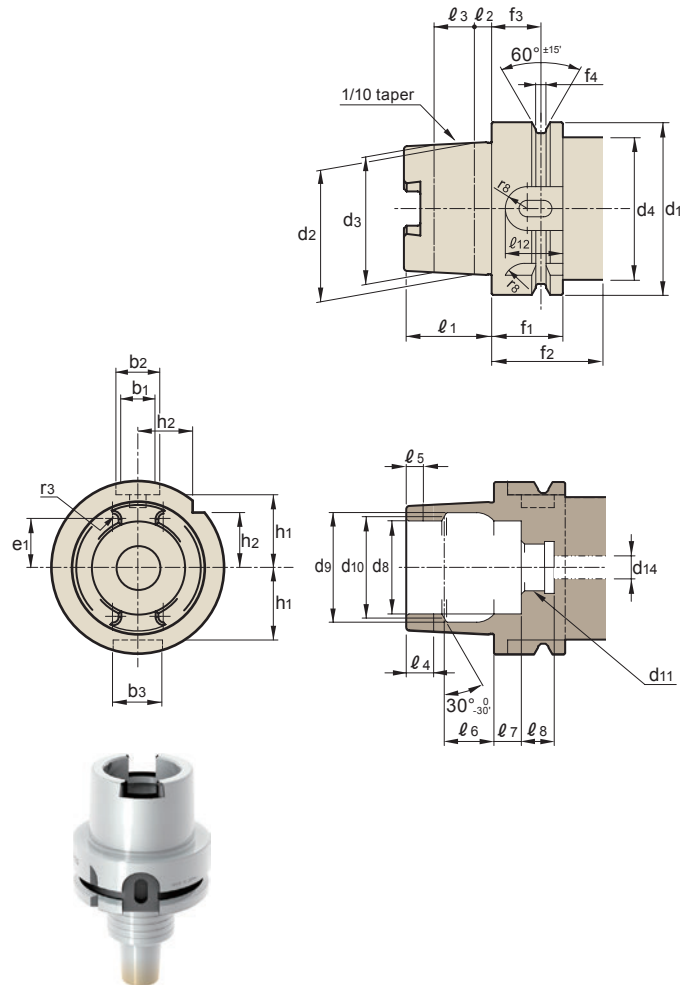

HSK-E (Extracts from DIN V 69893-5;1996-01)

Shank	E25	E32	E40	E50
d1 (h10)	25	32	40	50
d2	19	24	30	38
	+0.006 +0.004	+0.007 +0.005	+0.007 +0.005	+0.009 +0.006
d3	18.15	23.27	29.05	36.90
	+0.004 +0.002	+0.005 +0.003	+0.005 +0.003	+0.006 +0.003
d4 (Max.)	20	26	34	42
d8 (H10)	14	17	21	26
d9 (H11)	16.4	21	25.5	32
d10	15	19	23	29
d11 (Max.)	3	4.2	5	6.8
l1 ($-\frac{0}{-0.2}$)	13	16	20	25
l2	2.5	3.2	4	5
l3	8.5	7.3	9.5	11
l4 (JS10)	7.21	8.92	11.42	14.13
l5 ($-\frac{0}{-0.1}$)	6	8	8	10
f1 ($-\frac{0}{-0.1}$)	10	20	20	26
f2 (min.)	20	35	35	42
f3 (± 0.1)	4.5	16	16	18
f4 ($+\frac{0.15}{0}$)	2	2	2	3.75

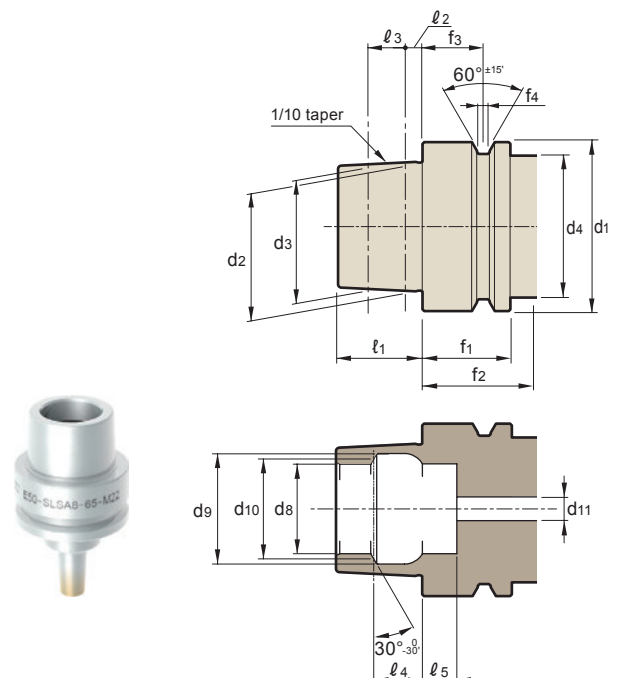

Feature
Shrink-fit Heater
MONO 3° MONO CURVE
MONO Series
2PIECE type
UNO
HYPER version
STRAIGHT arbor
OTHERS
PERIPHERALS
Technical Information

HSK-F (Extracts from DIN V 69893-6;1996-01)

Shank	F63	F80
d1 (h10)	63	80
d2	38	48
	+0.009 +0.006	+0.011 +0.007
d3	36.9	46.53
	+0.006 +0.003	+0.007 +0.003
d4 (Max.)	53	67
d8 (H10)	26	34
d9 (H11)	32	40
d10	29	37
f1 ($-\frac{0}{-0.1}$)	26	26
f2 (min.)	42	42
f3 (± 0.1)	18	18
f4 ($+\frac{0.15}{0}$)	3.75	3.75
l1 ($-\frac{0}{-0.2}$)	25	32
l2	5	6.3
l3	11	14.7
l4 (Js10)	14.13	18.13
l5 ($-\frac{0}{-0.1}$)	10	10
f1 ($-\frac{0}{-0.1}$)	26	26
f2 (min.)	42	42
f3 (± 0.1)	18	18
f4 ($+\frac{0.15}{0}$)	3.75	3.75

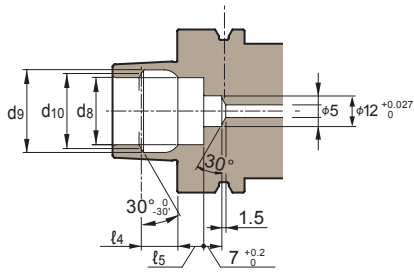
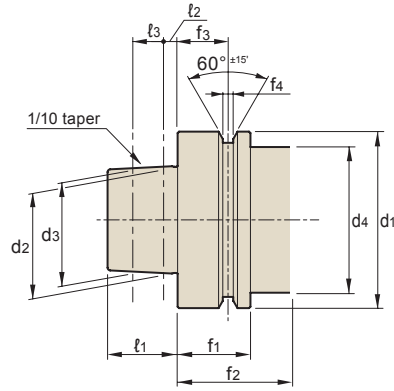

HSK-T (Extracts from ISO 12164-3;2008) For turning with turning mill machines

Shank	T40	T50	T63	T100	T125
b1 ($+\frac{0.04}{-0.04}$)	8.05	10.54	12.54	20.02	25.02
b2 (H10)	9	12	16	20	25
b3 (H10)	11	14	18	22	28
b5	7.932	10.425	12.425	19.91	24.915
	+0.03 0		+0.035 0		+0.04 0
d1 (h10)	40	50	63	100	125
d2	30.007	38.009	48.010	75.013	95.016
d3 (H10)	21	26	34	53	67
d4 (H11)	25.5	32	40	63	80
d5	23	29	37	58	73
d6 (Max.)	5	6.8	8.4	12	14
d8	4.6	6	7.5	12	—
d9 (Max.)	39	49	62	99	124
d15	M12 × 1	M16 × 1	M18 × 1	M24 × 1.5	M30 × 1.5
e1	11	13.88	17.99	27.37	35.37
f1 ($-\frac{0}{-0.1}$)	20	26	26	29	29
f2 (min.)	23	30	30	34	34
f3 (± 0.1)	16	18	18	20	20
f4 ($+\frac{0.15}{0}$)	2	3.75	3.75	3.75	3.75
h1 ($-\frac{0}{-0.2}$)	17	21	26.5	44	55.5
h2 ($-\frac{0}{-0.3}$)	12	15.5	20	31.5	39.5
l1 ($-\frac{0}{-0.2}$)	20	25	32	50	63
l2	4	5	6.3	10	12.5
l3 ($-\frac{0.2}{0}$)	6	7.5	10	15	19
l4 ($-\frac{0.2}{0}$)	3.5	4.5	6	10	12
l5 (JS10)	11.42	14.13	18.13	28.56	36.27
l6 ($-\frac{0}{-0.1}$)	8	10	10	12.5	16
l9 ($-\frac{0}{-0.3}$)	8	10	12	16	18
l12	12	19	21	24	24
r3 ($+\frac{0.05}{-0.05}$)	1.88	2.38	2.88	4.88	5.88
r9	4.5	6	8	10	5

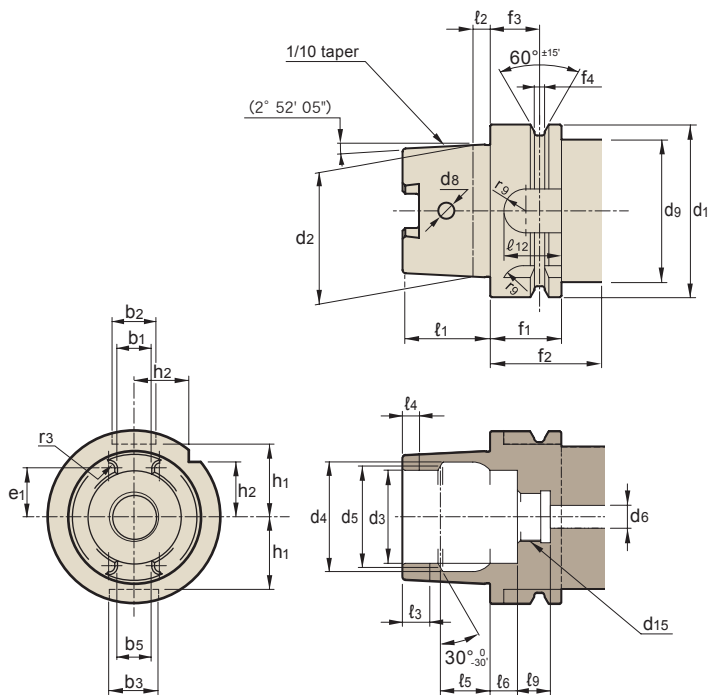

BT (Extracts from MAS 403)

Shank	BT30	BT40	BT50
D1	31.75	44.45	69.85
ℓ1 (± 0.15)	48.4	65.4	101.8
d2 (H8)	12.5	17	25
g (6H)	M12	M16	M24
ℓ2 (min.)	24	30	45
ℓ3 (min.)	34	43	62
ℓ4	7	9	13
b (H12)	16.1	16.1	25.7
ℓ5 (min.)	17	21	31
t (-0.2)	16.3	22.6	35.4
D5 (h8)	46	63	100
f	20	25	35
v (± 0.1)	13.6	16.6	23.2
y (± 0.4)	2	2	3

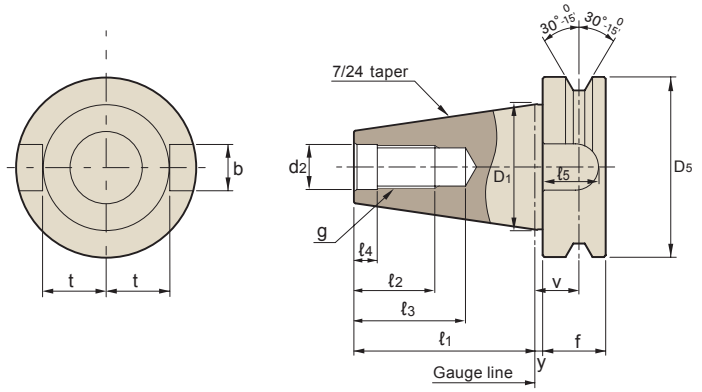

DIN (DIN69871-1)

Shank	DN40	DN50
D1	44.45	69.85
D2	63.55	97.5
D3	56.25	91.25
D4	50	80
L1	68.4	101.75
L3	3.75	6.495
b1	16.1	25.7
d1	17	25
t1	22.8	35.5
t2	25	37.7
t3	18.5	30

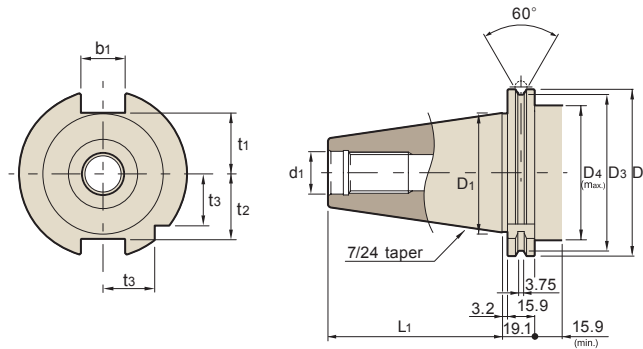

CAT.

Shank	CT40	CT50
D1	1.75"	2.75"
D2	2.5"	3.88"
D3	2.22"	3.59"
D4	1.75"	2.75"
L1	2.69"	4"
b1	.65"	1.06"
d1	.64"	1.03"
t1	.99"	1.49"
t2	.84"	1.39"

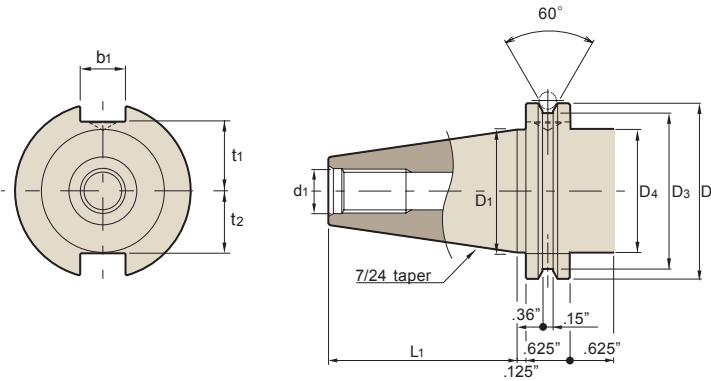

HSK-A125/ F80PD are also available as standard products.

If you would like more detailed information, please contact MST and ask for a catalog.

Dimensional tolerance of typically used mating (JIS B 0401)

The class of dimension(mm)		The tolerance of the hole dimension (μm)						The tolerance of the shaft dimension (μm)					
More than	Less than	H4	H5	H6	H7	H8	H9	h4	h5	h6	h7	h8	h9
—	3	+3 0	+4 0	+6 0	+10 0	+14 0	+25 0	0 -3	0 -4	0 -6	0 -10	0 -14	0 -25
3	6	+4 0	+5 0	+8 0	+12 0	+18 0	+30 0	0 -4	0 -5	0 -8	0 -12	0 -18	0 -30
6	10	+4 0	+6 0	+9 0	+15 0	+22 0	+36 0	0 -4	0 -6	0 -9	0 -15	0 -22	0 -36
10	18	+5 0	+8 0	+11 0	+18 0	+27 0	+43 0	0 -5	0 -8	0 -11	0 -18	0 -27	0 -43
18	30	+6 0	+9 0	+13 0	+21 0	+33 0	+52 0	0 -6	0 -9	0 -13	0 -21	0 -33	0 -52
30	50	+7 0	+11 0	+16 0	+25 0	+39 0	+62 0	0 -7	0 -11	0 -16	0 -25	0 -39	0 -62

Conversion table for International System of Units

Force

N	kgf
1	1.01972×10 ⁻¹
9.80665	1

Pressure

Pa	kgf/cm ²
1	1.0197×10 ⁻⁵
9.80665×10 ⁴	1

Stress

Pa	kgf/mm ²
1	1.0197 × 10 ⁻⁷
9.80665 × 10 ⁶	1

OVERSEAS NETWORK

Logistic center (J-COMPO) • USA/Chicago • Germany/Nuremburg • Thai



2304

< Europe >

AUSTRIA 1 distributor		BELGIUM 2 distributors		MachinImmo BVBA	
STEINDL Vertriebs GmbH		DIATOOL BVBA		LOKEREN	
Söding ☐ info@steindl.at		TURNHOUT ☐ info@diatool.be		TEL 32-14401830 FAX 32-14438880 ☐ mc@machinimmo.com TEL 32-93288811	
CZECH REPUBLIC 2 distributors		ESTONIA 1 distributor		FINLAND 1 distributor	
Creative Tools s.r.o.		OSG		Naglis & Err sia	
SKALKKA ☐ info@creative-tools.cz		BRATISLAVA ☐ info@osg-belgium.com		RIGA ☐ info@naglis-err.com	
TEL 420-725588988 FAX 420-582384485		TEL 421-43291295		TEL 37-166100336	
DENMARK 2 distributors		FRANCE 2 distributors		GERMANY 4 distributors	
Balling Maskiner ApS		OSG France s.a.r.l.		Aura Frästechnik GMBH	
KOLDING ☐ mbp@balling-maskiner.dk		ROISSY ☐ sales@osg-france.com		BREIDENBACH ☐ kontakt@aura-tools.de	
TEL 45-24790300		TEL 33-149901010 FAX 33-149901015		TEL 49-64659119414 FAX 49-64659119429	
ITALY 4 distributors		ITALY 4 distributors		ITALY 4 distributors	
MAKINO ITALIA S.R.L.		MMC EMILIA ROMAGNA SRL		OSG GMBH	
Cavenago di Brianza ☐ info@mmc-italia.it		MODENA ☐ info@mmcemilia.it		Göppingen ☐ info@osg-germany.de	
TEL 39-(02)95948290 FAX 39-(02)95948240		TEL 39-0536946687 FAX 39-0536946695		TEL 49-716160640 FAX 49-7161606444	
MMC ITALIA SRL		OSG ITALIA SRL		Schreurs-tools GMBH	
MILANO ☐ info@mmc-italia.it		TORINO ☐ info@osg-italia.it		KERNEN ☐ info@schreurs-tools.de	
TEL 39-029377031 FAX 39-0293589093		TEL 39-0117705211 FAX 39-0117071402		TEL 49-715195899-0	
LATVIA 1 distributor		LITHUANIA 1 distributor		HUNGARY 1 distributor	
Naglis & Err sia		Naglis & Err sia		GesKor Kft.	
RIGA ☐ info@naglis-err.com		RIGA ☐ info@naglis-err.com		KUNSZIGET ☐ office@geskor.com	
TEL 37-166100336		TEL 37-166100336		TEL 36-96200075	
NETHERLANDS 3 distributors		NORWAY 2 distributors		PORTUGAL 1 distributor	
Machining Innovations NL bv-Machinno		AS NOR-SWISS		AMTOOLS	
MERSELO ☐ info@machinno.com		OSLO ☐ norswiss@norswiss.no		MARINHA GRANDE ☐ geral@amtools.pt	
TEL 32-93288811		TEL 47-23241020 FAX 47-23241021		TEL 351-244560456 FAX 351-244560668	
NORWAY 2 distributors		POLAND 3 distributors		ROMANIA 2 distributors	
OSG Nederland B.V.		Aura Frästechnik GMBH		MAZAROM IMPEX SRL	
HARMELEN ☐ info@osg-nl.com		☐ k.kosla@aura-tools.de		BUCHAREST ☐ mazarom@mazarom.ro	
TEL 31-348442764		TEL 48-666011225 FAX 49-64659119429		TEL 40-212328001 FAX 40-212328002	
PORTUGAL 1 distributor		ROMANIA 2 distributors		SLOVAKIA 2 distributors	
SVM Freestechniek B.V.		ROMANIA 2 distributors		SLOVAKIA 2 distributors	
BERGEIJK ☐ info@svmfreestechniek.nl		TOP METROLOGY S.R.L.		MAKINO S.R.O.	
TEL 31-648490933		BUCHAREST ☐ office@topmetrology.ro		BRATISLAVA ☐ info@makino-sro.com	
TEL 31-648490933		TEL 40-314358402		TEL 421-249612100 FAX 421-249612400	
RUSSIA 2 distributors		SLOVENIA 2 distributors		SLOVENIA 2 distributors	
Company PromArsenal LLC		Aura Frästechnik GMBH		BTS COMPANY d.o.o.	
CHELYABINSK ☐ sales@promarsenal.ru		ŽALEC ☐ info@kactrade.si		LJUBLJANA ☐ info@bts-company.si	
TEL 7-3512253138		TEL 386-37104080		TEL 386-15841400 FAX 386-15249224	
SodicoM-Center		SPAIN 3 distributors		SPAIN 3 distributors	
MOSCOW ☐ info@sodick.ru		DELFIN COMPONENTES S.L.		JANA TOOLS SL	
TEL 7-4957870970		VIZCAYA ☐ delfincomponentes@delfincomponentes.com		SONDIKA ☐ info@jana-tools.com	
		TEL 34-944105544 FAX 34-944105544		TEL 34-944538224 FAX 34-944538225	
SWEDEN 1 distributor		SWITZERLAND 1 distributor		UTILTALL S.A.	
OSG SCANDINAVIA A/S		STREULI TECHNOLOGIES AG		BARCELONA ☐ comercial@utiltall.es	
BROMÖLLA ☐ osg@osg-scandinavia.com		BIRMENS DORF ☐ info@streuli-techno.ch		TEL 34-934984465 FAX 34-933086993	
TEL 46-40412255 FAX 46-40413255		TEL 41-17394070 FAX 41-17394077			

TURKEY 3 distributors**FORM TEKNİK**

ISTANBUL

MR. ISMAIL CINAR TEL 90-2122973397
 info@form-teknik.com FAX 90-2122566215

TANDEM TAKIM TEZGAHLARI

ISTANBUL

MR. TANKUT KOCAK TEL 90-2163131413
 tankut.kocak@tandem.com.tr FAX 90-2163131411

TEKNİKA HIRDAVAT SANAVI VE TICARET LTD. STL.

ISTANBUL

MR. MEHMET AKKAYA TEL 90-2126742864
 info@teknikatools.com FAX 90-2126742863

UK 4 distributors**MATSUURA MACHINERY LTD**

LEICESTERSHIRE

TEL 44-1530511400
 FAX 44-1530511442

MMC HARDMETAL U.K. LTD

TAMWORTH

sales@mitsubishicarbide.co.uk TEL 44-1827312312
 FAX 44-1827312314

OSG UK LTD.

ESSEX

sales@osg-uk.com TEL 44-8453051066
 FAX 44-8453051067

KYOCERA SGS PRECISION TOOLS EUROPE LTD.

BERKSHIRE

salesEU@kyocera-sgstool.com TEL 44-1189795200
 FAX 44-1189795295

<North America>

U.S.A 9 distributors**Kitagawa NorthTech Inc.**

HQ - Schaumburg, IL (Great Lake)

MR. SHAWN LUSCHIE TEL 1-800-222-4138
 info@kitagawa-usa.com FAX 1-847-310-9484

West Coast

MR. DAVID TAKAHASHI TEL 1-562-522-9749
 dtakahashi@kitagawa-usa.com FAX 1-847-310-9484

Southeastern

MR. ED BORSOS TEL 1-847-254-5422
 eborsos@kitagawa-usa.com FAX 1-847-310-9484

Northeast

MR. MATT GENOVESE TEL 1-203-912-8906
 mgenovese@kitagawa-usa.com FAX 1-847-310-9484

Southwest

MR. MIKE ROBERTS TEL 1-847-284-7626
 mroberts@kitagawa-usa.com FAX 1-847-310-9484

MN, IA, ND, SD, NE

MR. REID SWANSON TEL 1-612-281-7476
 reidswans@msn.com FAX 1-847-310-9484

SINGLE SOURCE TECHNOLOGIES, INC.

HQ - Auburn Hills, MI

sst.millingteam@singlesourcetech.com TEL 1-248-232-6260

OH

MR. RON DICKUM TEL 1-814-969-6236
 Ronald.Dickum@singlesourcetech.com

FL (SC, GA)

MR. BEN GUEST TEL 1-321-319-5525
 Ben.Guest@singlesourcetech.com

NY (PA)

MR. PAUL MAYR TEL 1-814-833-2246
 Paul.Mayr@singlesourcetech.com

MI

MR. BRAD COOK TEL 1-248-302-6814
 Brad.Cook@singlesourcetech.com

WI

MR. STEVE KLUG TEL 1-262-202-0500
 Steve.Klug@singlesourcetech.com

AL (TN, TX, MS, AR)

MR. BOB ASH TEL 1-256-200-1100
 Bob.Ash@singlesourcetech.com

YAMAZEN INC.

HQ - Elk Grove Village, IL TEL 1-800-228-2969
 toolingsupport@yamazen.com FAX 1-847-882-9056

CA

TEL 1-800-228-2969
 toolingsupport@yamazen.com FAX 1-847-882-9056

MI

TEL 1-800-228-2969
 toolingsupport@yamazen.com FAX 1-847-882-9056

GA (SC, AL, TN, MS, NC, VA)

TEL 1-800-228-2969
 toolingsupport@yamazen.com FAX 1-847-882-9056

IL (NE, MO, KS, WI, TX)

TEL 1-800-228-2969
 toolingsupport@yamazen.com FAX 1-847-882-9056

AZ (NM, NV, UT, WA, OR, ID, MT, WY, CO)

TEL 1-800-228-2969
 toolingsupport@yamazen.com FAX 1-847-882-9056

IN (KY)

TEL 1-800-228-2969
 toolingsupport@yamazen.com FAX 1-847-882-9056

CT (PA, MD, DE, MA, ME, RI, NY, VT, NH, NJ)

TEL 1-800-228-2969
 toolingsupport@yamazen.com FAX 1-847-882-9056

CANADA 3 distributors**TRIUMPH TOOL LTD.**

Guelph, ON

MR. RICH MORRISON TEL 1-519-836-4811
 richm@triumphtool.com FAX 1-519-836-7903

Woodbridge, ON

MR. PATRICK DUFFY TEL 1-905-850-2323
 patrickd@triumphtool.com FAX 1-905-850-2322

Windsor, ON

MR. SHAWN LESPERANCE TEL 1-519-251-1771
 shawnl@triumphtool.com FAX 1-519-251-0770

OSG CANADA LTD.

ONTARIO, Burlington

MR. ROB ADKINS TEL 1-905-632-8032
 rob.adkins@osgcanada.com FAX 1-905-632-8466

SINGLE SOURCE TECHNOLOGIES, INC.

Windsor, ON

MS. RACHEL HUGHSON TEL 1-519-999-0719
 rachel.hughson@singlesourcetech.com

MEXICO 6 distributors**AHNSA TOOLS s.a.**

MONTERREY

MR. HORACIO CAMPOS TEL 52-81-8126-1000
 hcamos@ahnsa.com FAX 52-81-8126-1001

MMC METAL DE MEXICO S.A. DE C.V.

QUERETARO

MR. GUILLERMO ORTIZ TEL 52-442 192 6800
 lortiz@mmcex.com FAX 52-442 221 6134

SINGLE SOURCE TECHNOLOGIES, de R.L.de C.V.

QUERETARO

MR. MAURICIO MONTESINOS TEL 52-442-824-9399
 mauricio.montesinos@singlesourcetech.com

YAMAZEN MEXICANA S.A. DE C.V.

LEON

MR. GERARDO PLASCENCIA TEL 52-477-3910280
 gerardo.perez@yamazen.com.mx FAX 52-477-3910278

Kitagawa NorthTech Inc.

QUERETARO

MR. ARTURO LOZANO TEL 52-81-2029-0349
 alozano@kitagawa-usa.com

OSG / ROYCO, S.A. DE C.V.

MEXICO CITY

MR. TOSHITAKA YOSHIZAKI TEL 52-55-51-19-3363
 toshi@osgroyco.com.mx FAX 52-55-51-19-3370

MONTERREY

MR. ROMAN CAMPOS TEL 52-442-101-6009
 roman.campos@singlesourcetech.com

<South America>

BRAZIL 2 distributors**OSG FERRAMENTAS DE PRECISAO LTDA.**

SAN PAULO

SALES DEPARTMENT TEL 55-11-6190-0900
 osgsp@nethall.com.br FAX 55-11-6190-0901

INNOVATE TECHNOLOGIES Brasil LTDA

SAN PAULO

MR. LUCIANO CHIQUETTE TEL 55-19-3829-9280
 luciano.chiquette@innovatetech.com.br

<Oceania>

New Zealand 1 distributor**MANUFACTURING QUALITY TOOLING LIMITED**

AUCKLAND

MR. Phil MITCHELL TEL 64-21610909
 sales@mqtooling.com

<East Asia>**CHINA** 21 distributors

AUTOFACT MACHINERY LTD.
亞動機械有限公司
DONGGUAN 東莞
☎ MS. LILY GUAN 关星 TEL 86-769-81157228
✉ lily@autofact.com.hk FAX 86-769-81157229

DONGGUAN YAJIYA Precision machinery Co., Ltd
東莞八字屋精密機械有限公司
DONGGUAN 東莞
☎ MR. JASON LEE 李忠信 TEL 86-769-8530-7420
✉ sales@yajiya.cn FAX 86-769-8530-7470

Dongguan Integrity Precision Machinery Co., Ltd.
東莞市誠晉精密機械有限公司
DONGGUAN 東莞
☎ MR. YANG YABIN 楊亞兵 TEL 86-769-82288607
✉ frank.yang@chengjinjm.com.cn FAX 86-769-82288609

Fineness Corporation
匯穎國際貿易(上海)有限公司
SHANGHAI 上海
☎ MR. STEVE HU 胡上千/MR. ROY LU 呂旺動 TEL 86-21-64282885
✉ steve@fct-tools.com FAX 86-21-64391906

DONGGUAN 東莞
☎ MR. ALAN CHEN 陳宏儒 TEL 86-769-82284785
✉ alan@fct-tools.com FAX 86-769-8228-4797

GALAXY PRECISION MACHINERY LTD
佳力精密機械有限公司
SHENZHEN 深圳
☎ MR. LIANG MING 梁明 TEL 86-755-2966-0881
✉ gp613@galaxy-mt.com FAX 86-755-2966-0882

CHENGDU 成都
☎ MR. JASON HUANG 黃琳琳 TEL 86-28-83112969
✉ jasonhuang1121@163.com FAX 86-28-8311-2969

TIANJIN 天津
☎ MR. YANG JIAN 楊建 TEL 86-22-8739-5825
✉ isabat_yang@fct-tools.com FAX 86-22-8739-5827

JECO PRECISION LTD.
捷高精密機械有限公司
HONGKONG 香港
☎ MS. CATHY WONG 黃玉珍 TEL 852-2428-8328
✉ cathy@jeco.hk FAX 852-2428-3683

KUNSHAN KUNQIAO TRADING CO.,LTD.
坤僑貿易有限公司
KUNSHAN 昆山
☎ MR. CHOU TING SHENG 周廷升 TEL 86-512-57507151
✉ kjcorp@ms56.hinet.net FAX 86-512-57507153

SHENZHEN 深圳
☎ MR. GHENG-NAN, YEH 葉正男 TEL 86-755-81786391~2
✉ kj.com@msa.hinet.net FAX 86-755-8178-6670

JIANZE MACHINERY TECHNOLOGY CO.,LTD
上海建澤機械技術有限公司
SHANGHAI 上海
☎ MR. XUE JIANMING 薛建明 TEL 86-21-5155-7657
✉ xuejianming@jianze.net FAX 86-21-5155-7668

OSG SHANGHAI
歐士機(上海)精密工具有限公司
SHANGHAI 上海
☎ MS. JI MIN 嵇敏 TEL 86-21-5888-6600
✉ jimin@chinaosg.com FAX 86-21-5888-3300

PRO-TECHNIC MACHINERY LTD.
寶力機械有限公司
HONG KONG 香港
☎ MR. ALDO, S.K. CHEUNG 張四繼 TEL 852-2428-2727
✉ aldocheung@protechnic.com.hk FAX 852-2480-4764

MAKINO CHINA CO.,LTD.
牧野機床(中國)有限公司
KUNSHAN 昆山
☎ MR. LIU HAORAN 劉浩然 TEL 86-512-5777-8000
✉ info@makino.com.cn FAX 86-512-5777-9900

RSE (DALIAN) INTERNATIONAL TRADING CO LTD
美立吉(大連)國際貿易有限公司
DALIAN 大連
☎ MR. LI GANG 李剛 TEL 86-411-8750-8552
✉ 01@chinarse.com FAX 86-411-8750-8553

SHANGHAI FUDIAN HARDWARE TOOLS CO.,LTD
上海富點五金工具有限公司
SHANGHAI 上海
☎ MR. PAN JUNJUN 潘軍軍 TEL 86-21-5081-6127-127
✉ ada@shanghaifd.com FAX 86-21-6876-6870

SHANGHAI ELT TRADING CO.,LTD.
上海勳策貿易有限公司
SHANGHAI 上海
☎ MR. PETER LI 李曉剛 TEL 86-21-6071-3668
✉ peter@shelt.com.cn FAX 86-21-6071-3669

SHENZHEN SHI YINGFENGDA TRADING CO.,LTD
深圳市盈峰達貿易有限公司
SHENZHEN 深圳
☎ MR. ZHANG CHENGZHONG 張承忠 TEL 86-755-25109822
✉ Kelvin@yfd-group.com.cn FAX 86-755-23286077

Shenzhen SCZY Technology Co.,Ltd
深圳思誠資源科技有限公司
SHENZHEN 深圳
☎ MR. Fog Zhong 鍾福泰 TEL 86-769-22186189
✉ sales@sczy.com FAX 86-769-22186191

QINGDAO 青島
☎ MR. PETER LI 李曉剛 TEL 86-532-5897-7052
✉ peter@shelt.com.cn FAX 86-532-8093-0907

SONDER TOOLS & MACHINERY(HK)LTD.
晨達(香港)有限公司
HONG KONG 香港
☎ MR. JOHNNY NG 吳偉良 TEL 852-2-964-0233
✉ johnnyng@sondertools.com FAX 852-2-964-0604

DONGGUAN 東莞
☎ MR. JOHNNY NG 吳偉良 TEL 86-769-22699687
✉ johnnyng@sondertools.com FAX 86-769-22699487

SHANGHAI REBAR CUTTING TOOLS CO., LTD
上海銳霸切削工具有限公司
SHANGHAI 上海
☎ MR. CUI YANJUN 崔岩軍 TEL 86-21-5108-5980
✉ steven_rb@126.com FAX 86-21-5763-2329

YAMAZEN CORPORATION
山善(上海)貿易有限公司
SHANGHAI 上海
☎ MR. KOZAWA 小澤 TEL 86-21-5445-2266
✉ kozawa@yamazensh.com. FAX 86-21-5445-2066

SHENZHEN 深圳
☎ MR. ONO 小野 TEL 86-755-8280-5000
✉ ono@yamazen.com.cn FAX 86-755-8280-5100

SHANGHAI RIJIN CNC TOOLS CO., LTD.
上海日進數控刀具有限公司
ZHEJIANG 浙江
☎ MS. YE LI HONG 葉麗紅 TEL 86-576-84232178
✉ cnrijin15@126.com FAX 86-576-84232178

DALIAN 大連
☎ MR. ZHUANG 莊震 TEL 86-411-8762-6323
✉ zhuangzhen@yamazensh.com FAX 86-411-8762-6332

CHONGQING 重慶
☎ MR. MORII 森井 TEL 86-23-6308-2799
✉ morii@yamazensh.com FAX 86-23-6308-2711

TOJU MACHINE-ELECTRICITY CO.,LTD
上海東住機電科技有限公司
SHANGHAI 上海
☎ MR. TIAN JUN 田軍 TEL 86-21-6413-8038
✉ sh_toju@163.com FAX 86-21-5230-8016

GUANGZHOU 廣州
☎ MR. YASUNO 安野 TEL 86-20-8732-1601
✉ yasuno@yamazen.com.cn FAX 86-20-8732-1232

TAIWAN 2 distributors

KUNJUNG CORPORATION
坤嶸企業有限公司
TAIPEI 台北
☎ MR. CHUNG-WEI, HUANG 黃崇維 TEL 886-2-22902500
✉ kjcorp@ms56.hinet.net FAX 886-2-22902515

KOREA 7 distributors

KUK SUNG INTERNATIONAL CO.,LTD.
국성인터내셔널주식회사
DAEGU 大邱
☎ MR. CHOI BYUNG HOON 崔秉勳 TEL 82-53-604-0521
✉ kuksung@kuksung.com FAX 82-53-604-0525

HWA JIN TRADING CO.,LTD.
(주) 화진교역
SEOUL 서울
☎ MR. KANG YONG KWON 姜勇勳 TEL 82-2-803-2127
✉ hwajin-mhte@naver.com FAX 82-2-803-2129

KAOSHUNG 高雄
☎ MR. TSUNG-LIEH, HO 何宗烈 TEL 886-7-7231101
✉ chdhor@pchome.com.tw FAX 886-7-7236088

ITM KOREA
SUWON 水原
☎ MR. LEE SANGKWAN 이상관 TEL 82-31-291-0917
✉ itm-korea2015@gmail.com FAX 82-50-4465-7218

MIRAE TECHNO 미래테크노
GWANGMYEONG 光陽
☎ MR. PARK HO SUNG 박호성 TEL 82-2-899-0531
✉ miraetechno@hanmail.net FAX 82-2-899-0532

TAICHUNG 台中
☎ MR. MING-CHIEH, YEN 顏明傑 TEL 886-4-27026477
✉ kj.com@msa.hinet.net FAX 886-4-24520439

NS KOREA CO.,LTD. (주)엔에스코리아
ANYANG 安陽
☎ MR. BAI JAMES 백성진 TEL 82-31-450-3335
✉ info@ns-korea.com FAX 82-31-450-3339

OSG KOREA CORPORATION 한국OSG주식회사
DAEGU 大邱
☎ MR. JANG JUN YOUNG 張俊榮 TEL 82-53-589-2054
✉ jyjjang@osg.co.kr FAX 82-53-583-5553

CENTURY TRADING CORPORATION
世紀貿易股份有限公司
TAIPEI 台北
☎ MR. YAN YUNGTA 顏永達 TEL 886-2-2298-8336
✉ ytyan@centra.com.tw FAX 886-2-2298-8338

YAMAZEN (KOREA) LTD. (주)야마젠코리아
SEOUL 서울
☎ MR. SEO SANG DUK 서상덕 TEL 82-2-864-1755
✉ yamazen@yamazenkorea.co.kr FAX 82-2-864-1758

<South Asia>

INDIA 12 distributors

MAKINO INDIA PVT. LTD.
BANGALORE/CHENNAI/GURGAON/PUNE/COIMBATORE
MR. B.V. SRIDHAR TEL 91-8067419500
sridhar@makino.co.in

ANANTHA TOOLTECH
BANGALORE
MR. SREEDHAR S SHENOY TEL 91-9845040071
techsupport@ananthatooltech.com

ICON INDUSTRIAL SOLUTIONS
CHENNAI
MR. M. SRINIVASAN TEL 91-4422351336
srinivasan@icontoolings.com

MERAKI TOOLS
MUMBAI / AHMEDABAD
MR. ASHLIE D'BRITTO TEL 91-8806511818
sales@merakitools.in

METACUT TECHNOLOGIES
DELHI
MR. RAJAT VERMA TEL 91-9911310300
rajat.metacut@gmail.com

MMC HARDMETAL INDIA PVT. LTD.
BANGALORE
MR. HIROSHI YURI TEL 91-802308-3400
mmcindia@mmc.co.jp

NETRA TECHNOLOGIES
AHMEDABAD
MR. CHIRAG PATEL TEL 91-9722323111
netratechno@gmail.com

ORION INNOTECH PVT. LIMITED
GURGAON / CHENNAI / PUNE
MR. VISHAL VERMA TEL 91-1244225210
vishal@oriongroup.in

OSG (INDIA) PVT. LTD.
GURGAON
MR. ANUP KUMAR DAS TEL 91-1244009737
anup@osg-india.com

PASS TECH
COIMBATORE
MR. BOOPATHY K. TEL 91-9600906000
boopathy@passtech.in

VALIANT INDIA
PUNE
MR. VIRENDRA MAYNALE TEL 91-9371672785
sales@valiantindia.in

YAMAZEN MACHINERY & TOOLS INDIA PVT. LTD.
GURGAON / BANGALORE / CHENNAI / PUNE / AHMEDABAD
MR. RYO AKIYAMA TEL 91-1244605900
india1@yamazen.co.jp

INDONESIA 4 distributors

PT. ASIA PHINISI MANDIRI
TANGERANG / CIKARANG
MR. HERI TEL 62-2155661357
heri@asiaphinisi.co.id

MEC-MART TOOLINGS SDN. BHD
KUALA LUMPUR / PENANG / JOHOR
MR. NICHOLAS TOH TEL 60-356330932
nicholastoh@mecmart.com.my

MAKINO ASIA PTE LTD.
MR. SAM SHUKOR TEL 65-6861-5722
sam@makino.com.sg

PT. JAVATEC TRIMITRA MACHINERY
JAKARTA
MR. JONATAN ARIF SANTOSO TEL 62-21-4584-9988
jonatan@javatec-machinery.com FAX 62-21-4584-8899

NEWLINE MACHINE TOOL SDN.BHD.
KUALA LUMPUR
MR. JEFFREY P.W CHOON TEL 60-3-8961-1973
jeff@newlinemachine.com

NOBELTECH PTE LTD
MR. ERIC CHAN TEL 65-6749-3636
eric@nbel.com.sg

PT. RUKUN SEJAHTERA TEKNIK
JAKARTA
MR. FRANKIE ANGGADHA TEL 62-21-628-1615
marketing@rsttools.com FAX 62-21-626-5559

ROBO TECH MACHINERY SDN. BHD
KUALA LUMPUR
MR. TEO CHENG CHUAH TEL 60-355697877
ccteo@haasmalaysia.com

OSG ASIA PTE LTD.
MR. YASUTAKA YONEDA TEL 65-6844-4350
yasuyoneda@osgasia.com.sg

PT. YAMAZEN INDONESIA
JAKARTA/CIKARANG
MR. KENTA YOSHIMIZU TEL 62-21-451-3345
yoshimizu@yamazen.co.id FAX 62-21-451-3346

YAMAZEN (MALAYSIA) SDN.BHD.
KUALA LUMPUR/PENANG/JOHOR
MR. YOSHITAKA KUWABARA TEL 60-3-5569-5099
kuwabara@yamazen.com.my

YAMAZEN (SINGAPORE) PTE LTD.
MR. KAZUNORI WATASHIGE TEL 65-6276-9488
watashige@yamazen.com.sg

PHILIPPINES 3 distributors

YAMAZEN MACHINERY & TOOLS PHILIPPINES, INC.
LAGUNA
MR. RYO SONISHI TEL 63-49-543-1958
r.sonishi@yamazen.com.ph FAX 63-49-508-0893

KAMOGAWA LAGUNA PHILIPPINES INC
LAGUNA
MR. TAKAHIRO FUNAKUBO TEL 63-49-576-4931
t.funakubo@kamog.co.jp FAX 63-49-508-3199

NICKLAUS MACHINERY CORPORATION
MANILA
MS. CAMIE CHEN TEL 63-27-118-414
nicklaus-machinery@pldtsl.net FAX 63-27-121-225

THAILAND 7 distributors

FACTORY MAX CO.,LTD.
BANGKOK
MR. S. TANGTARATORN TEL 66-2-759-9100
surapong@factorymax.co.th FAX 66-2-759-9009

MAKINO (THAILAND) CO.,LTD.
BANGKOK
MR. SHOGO NAKASUMA TEL 66-2-017-0123
nakasuma@makino.co.th FAX 66-2-971-5751

PRECISION TOOLS SERVICE (THAILAND) CO.,LTD.
BANGKOK
MR. HIROAKI ISHIKAWA TEL 66-2-186-4970
h_ishikawa@toyo-tos.com FAX 66-2-308-2471

RETRA ENGINEERING (THAILAND) CO.,LTD.
BANGKOK / CHONBURI
MR. KAZUHIRO SOEJIMA TEL 66-2-726-9535
soejima@retra-co-th.com FAX 66-2-726-9759

N-TECH MACHINERY CO.,LTD.
SAMUTPRAKARN
MS. JENNY TEL 66-2-136-5333
thaintech@yahoo.com FAX 66-2-136-5334

YAMAZEN (THAILAND) CO.,LTD.
BANGKOK / CHONBURI / KORAT
MR. KAZUYA OKADA TEL 66-2-374-5522
okada@yamazen.co.th FAX 66-2-374-3192

YONEZAWA ENGINEERING ASIA (THAILAND) CO.,LTD.
BANGKOK / RAYONG
MR. YUICHI MIKAMI TEL 66-2-769-5681
mikami@yea.co.th FAX 66-2-769-5683

VIETNAM 7 distributors

BM SYSTEM SOLUTION CO.,LTD.
HANOI
MR. WON RYANG HUR TEL 84-97-774-5488
bmssvina@daum.net

KAMOGAWA VIETNAM CO.,LTD
HANOI
MR. DAISUKE KATSURA TEL 84-24-378-550-22/23
katsura@kamog.co.jp FAX 84-24-378-550-23

HO CHI MINH
MR. TAKUMI TAFU TEL 84-28-391-054-77/78/79
tafu@kamog.co.jp FAX 84-8-3910-5480

KHANG THINH TECHNOLOGY IMPORT EXPORT CO.,LTD.
HO CHI MINH
Ms. ZOEY TEL 84-86-7743-986
sales1@kttech.vn

TFM TOOLS CO.,LTD.
BINH DUONG
MR. THANH TEL 84-9087666600
thanh@tfm.vn

T&B TECHNICAL SERVICES AND TRADING CO.,LTD
HANOI / HO CHI MINH
MR. LUU QUANG THOA TEL 84-24-6659-5103
thoa-luu@tbvn.com.vn

WOLFRAM INDUSTRIAL SERVICE JSC
HANOI / HO CHI MINH
MR. NGOC TEL 84-24-3793-2350
giangoc.nguyen@wolfram.vn FAX 84-24-3793-2320

YAMAZEN VIETNAM CO.,LTD
HANOI
MR. ATSUSHI KIKUCHI TEL 84-24-3728-6292
kikuchi@yamazenvn.com FAX 84-24-3766-4137

HO CHI MINH
MR. DAISUKE TOCHIGI TEL 84-28-5417-9229
tochigi@yamazenvn.com FAX 84-28-3820-2784

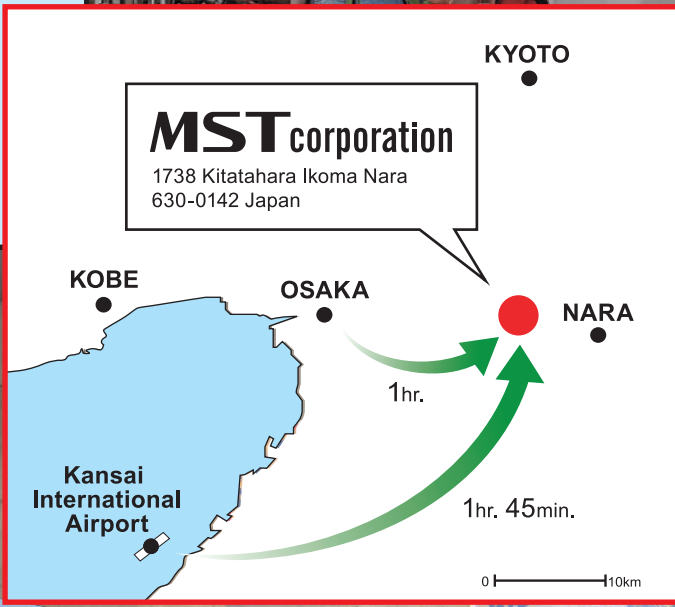

MST corporation
 1738 Kitahara Ikoma Nara
 630-0142 Japan

マシニングセンター
 の
 予知保全
 工場見学

SUB MICRON



HEAD OFFICE & FACTORY

1738 Kita-tahara, Ikoma,
Nara 630-0142 Japan
Tel : +81 743 78 1931
Fax : +81 743 78 3854
✉ : info@mst-corp.co.jp

MSTcorporation
<http://www.mst-corp.co.jp>